

$$\begin{array}{r} 123 \\ + 56 \\ \hline \end{array}$$

$$\begin{array}{r} 22 \\ + 88 \\ \hline \end{array}$$

$$\begin{array}{r} 22 \\ + 89 \\ \hline \end{array}$$

$$\begin{array}{r} 123 \\ + 456 \\ \hline \end{array}$$

$$\begin{array}{r} 123 \\ + 654 \\ \hline \end{array}$$

$$\begin{array}{r} 456 \\ - 321 \\ \hline \end{array}$$

$$\begin{array}{r} 132 \\ + 868 \\ \hline \end{array}$$

$$\begin{array}{r} 45 \\ + 45 \\ \hline \end{array}$$

$$\begin{array}{r} 444 \\ + 6 \\ \hline \end{array}$$

$$\begin{array}{r} 900 \\ + 100 \\ \hline \end{array}$$

$$\begin{array}{r} 8 \\ \times 4 \\ \hline \end{array}$$

$$\begin{array}{r} 8 \\ \div 4 \\ \hline \end{array}$$

$$\begin{array}{r} 64 \\ \div 45 \\ \hline \end{array}$$

$$\begin{array}{r} 111 \\ \times 5 \\ \hline \end{array}$$

$$\begin{array}{r} 111 \\ \times 10 \\ \hline \end{array}$$

$$\begin{array}{r} 64 \\ + 64 \\ \hline \end{array}$$

$$\begin{array}{r} 128 \\ + 128 \\ \hline \end{array}$$

$$\begin{array}{r} 256 \\ + 256 \\ \hline \end{array}$$

$$\begin{array}{r} 1024 \\ + 1024 \\ \hline \end{array}$$

$$\begin{array}{r} 1024 \\ \div 4 \\ \hline \end{array}$$

$$\begin{array}{r} 144 \\ - 12 \\ \hline \end{array}$$

$$\begin{array}{r} 12 \\ \times 3 \\ \hline \end{array}$$

$$\begin{array}{r} 12 \\ \times 10 \\ \hline \end{array}$$

$$\begin{array}{r} 144 \\ \div 12 \\ \hline \end{array}$$

$$\begin{array}{r} 12 \\ \times 13 \\ \hline \end{array}$$

$$\begin{array}{r} -2 \\ + -2 \\ \hline \end{array}$$

$$\begin{array}{r} 6 \\ \times 4 \\ \hline \end{array}$$

$$\begin{array}{r} -6 \\ \times 4 \\ \hline \end{array}$$

$$\begin{array}{r} 1111 \\ \div 11 \\ \hline \end{array}$$

$$\begin{array}{r} 756 \\ \times 10 \\ \hline \end{array}$$

$$\begin{array}{r} 1 \\ 2 \\ 3 \\ + 4 \\ \hline \end{array}$$

$$\begin{array}{r} 10 \\ 5 \\ + 6 \\ \hline \end{array}$$

$$\begin{array}{r} 7 \\ \times 3 \\ \hline \end{array}$$

$$\begin{array}{r} 56 \\ \div 2 \\ \hline \end{array}$$

$$\begin{array}{r} 21 \\ + 7 \\ \hline \end{array}$$

$$\begin{array}{r} 101 \\ \times 11 \\ \hline \end{array}$$

$$\begin{array}{r} 12 \\ \times 4 \\ \hline \end{array}$$

$$\begin{array}{r} 1212 \\ \div 12 \\ \hline \end{array}$$

$$\begin{array}{r} 3 \\ \times 6 \\ \hline \end{array}$$

$$\begin{array}{r} 18 \\ + 18 \\ \hline \end{array}$$

A number of bears search for berries in the woods. Each bear finds the same number of berries, which is the same as the number of bears. If they have thirty-six berries in total, how many bears are there?

$$\begin{array}{r} 28 \\ + 8 \\ \hline \end{array}$$

$$\begin{array}{r} 36 \\ + 28 \\ \hline \end{array}$$

$$\begin{array}{r} 8 \\ \times 8 \\ \hline \end{array}$$

$$\begin{array}{r} 36 \\ + 45 \\ \hline \end{array}$$

$$\begin{array}{r} 9 \\ \times 9 \\ \hline \end{array}$$

$$\begin{array}{r} 101 \\ \times 12 \\ \hline \end{array}$$

$$\begin{array}{r} 12 \\ \times 6 \\ \hline \end{array}$$

$$\begin{array}{r} 1313 \\ \div 13 \\ \hline \end{array}$$

$$\begin{array}{r} 12 \\ \times 12 \\ \hline \end{array}$$

$$\begin{array}{r} 360 \\ \div 5 \\ \hline \end{array}$$

Try to guess the next term in this sequence:

2, 2, 4, 6, 10, 16, 26, ...

$$\begin{array}{r} 6 \\ 7 \\ \hline + 8 \end{array}$$

$$\begin{array}{r} 13 \\ 14 \\ \hline 15 \end{array}$$

$$\begin{array}{r} 7 \\ \hline \times 3 \end{array}$$

$$\begin{array}{r} 14 \\ \hline \times 3 \end{array}$$

$$\begin{array}{r} 14 \\ 15 \\ \hline + 16 \end{array}$$

$$\begin{array}{r} 12 \\ \hline \times 7 \end{array}$$

$$\begin{array}{r} 96 \\ \hline \div 12 \end{array}$$

$$\begin{array}{r} 12,012 \\ \hline \div 12 \end{array}$$

$$\begin{array}{r} 9 \\ \hline \times 3 \end{array}$$

$$\begin{array}{r} 36 \\ \hline \div 9 \end{array}$$

Bonus question 1: Measure the angles of the triangle below with your protractor. Do they add up to 180 degrees?

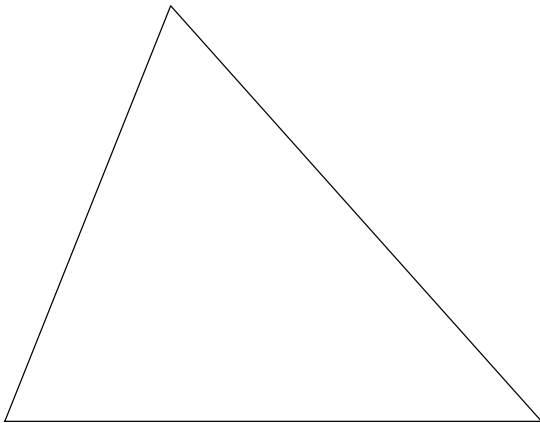

Bonus question 2: If Lala the leopard goes to bed at 8:45 pm, and wakes up at 7:15 am, how long has she slept?

$$\begin{array}{r} 72 \\ + 108 \\ \hline \end{array}$$

$$\begin{array}{r} 180 \\ + 90 \\ \hline \end{array}$$

$$\begin{array}{r} 360 \\ - 90 \\ \hline \end{array}$$

$$\begin{array}{r} 360 \\ \times 2 \\ \hline \end{array}$$

$$\begin{array}{r} 360 \\ \div 6 \\ \hline \end{array}$$

$$\begin{array}{r} 12 \\ \times 10 \\ \hline \end{array}$$

$$\begin{array}{r} 60 \\ \div 12 \\ \hline \end{array}$$

$$\begin{array}{r} 360, 360 \\ \div 360 \\ \hline \end{array}$$

$$\begin{array}{r} 9 \\ \times 4 \\ \hline \end{array}$$

$$\begin{array}{r} 108 \\ \div 2 \\ \hline \end{array}$$

Bonus question 1: How big are the two angles  $A$  in the triangle below?

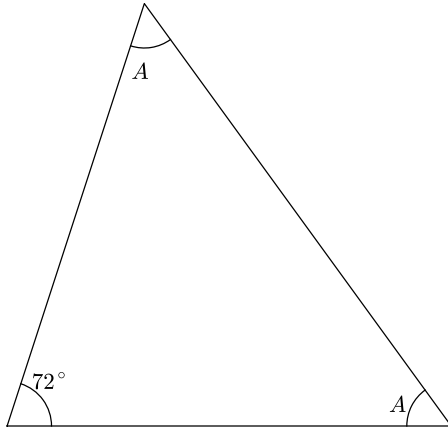

Bonus question 2: If Lala the leopard goes to bed at 7:30 am, and wakes up at 9 hours and a half hours later, when does she wake up?

$$\begin{array}{r} 7 \\ + 7 \\ \hline \end{array}$$

$$\begin{array}{r} 14 \\ + 28 \\ \hline \end{array}$$

$$\begin{array}{r} 6 \\ \times 7 \\ \hline \end{array}$$

$$\begin{array}{r} 70 \\ - 14 \\ \hline \end{array}$$

$$\begin{array}{r} 77 \\ \div 11 \\ \hline \end{array}$$

$$\begin{array}{r} 13 \\ \times 7 \\ \hline \end{array}$$

$$\begin{array}{r} 777 \\ \div 7 \\ \hline \end{array}$$

$$\begin{array}{r} 350 \\ \div 7 \\ \hline \end{array}$$

$$\begin{array}{r} 7 \\ \times 7 \\ \hline \end{array}$$

$$\begin{array}{r} 70 \\ \times 9 \\ \hline \end{array}$$

Bonus question 1: If Lala starts napping at 5:37 pm, and sleeps for one and a half hours, when does she wake up?

Bonus question 2: Suppose you live on the upper side of the river below (river bank A). You like taking walks, and you'd like to figure out a route that takes you over each of the seven bridges exactly once, and which ends back at your house. Is such a route impossible?

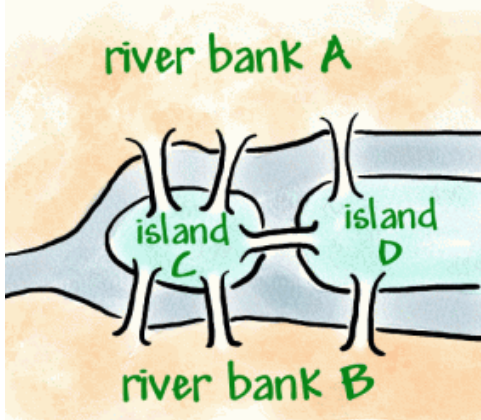

from <http://nrich.maths.org>

$$\begin{array}{r} 8 \\ + 8 \\ \hline \end{array}$$

$$\begin{array}{r} 64 \\ + 64 \\ \hline \end{array}$$

$$\begin{array}{r} 16 \\ \times 4 \\ \hline \end{array}$$

$$\begin{array}{r} 80 \\ - 16 \\ \hline \end{array}$$

$$\begin{array}{r} 128 \\ \div 16 \\ \hline \end{array}$$

$$\begin{array}{r} 12 \\ \times 8 \\ \hline \end{array}$$

$$\begin{array}{r} 48 \\ \div 8 \\ \hline \end{array}$$

$$\begin{array}{r} 640 \\ \div 8 \\ \hline \end{array}$$

$$\begin{array}{r} 8 \\ \times 8 \\ \hline \end{array}$$

$$\begin{array}{r} 1000 \\ \times 80 \\ \hline \end{array}$$

Bonus question: For this problem you should get out two dice: a four-sided die (a tetrahedron), and a six-sided die (a cube).

(1) Write down the number of vertices (points), edges, and faces (sides) for both the tetrahedron and the cube.

(2) For both the tetrahedron and the cube, what is: (the number of vertices) - (the number of edges) + (the number of faces)?



$$\begin{array}{r} 9 \\ + 9 \\ \hline \end{array}$$

$$\begin{array}{r} 81 \\ + 18 \\ \hline \end{array}$$

$$\begin{array}{r} 9 \\ \times 3 \\ \hline \end{array}$$

$$\begin{array}{r} 90 \\ - 18 \\ \hline \end{array}$$

$$\begin{array}{r} 90 \\ + 18 \\ \hline \end{array}$$

$$\begin{array}{r} 108 \\ \div 9 \\ \hline \end{array}$$

$$\begin{array}{r} 45 \\ \div 9 \\ \hline \end{array}$$

$$\begin{array}{r} 810 \\ \div 9 \\ \hline \end{array}$$

$$\begin{array}{r} 111 \\ \times 9 \\ \hline \end{array}$$

$$\begin{array}{r} 6 \\ \times 9 \\ \hline \end{array}$$

$$\begin{array}{r} 9 \\ \times 4 \\ \hline \end{array}$$

$$\begin{array}{r} 16 \\ \times 9 \\ \hline \end{array}$$

$$\begin{array}{r} 7 \\ \times 9 \\ \hline \end{array}$$

$$\begin{array}{r} 45 \\ + 54 \\ \hline \end{array}$$

$$\begin{array}{r} 13 \\ \times 9 \\ \hline \end{array}$$

Bonus question: What is the triangular number  $1 + 2 + 3 + 4 + 5 + 6 + 7 + 8 + 9$ ? (Hint: think about adding these in pairs.)

$$\begin{array}{r} 7 \\ \times 3 \\ \hline \end{array}$$

$$\begin{array}{r} 5 \\ \times 2 \\ \hline \end{array}$$

$$\begin{array}{r} 9 \\ \times 3 \\ \hline \end{array}$$

$$\begin{array}{r} 100 \\ - 90 \\ \hline \end{array}$$

$$\begin{array}{r} 3 \\ \times 4 \\ \hline \end{array}$$

$$\begin{array}{r} 100 \\ \div 10 \\ \hline \end{array}$$

$$\begin{array}{r} 4 \\ \times 4 \\ \hline \end{array}$$

$$\begin{array}{r} 3 \\ \times 3 \\ \hline \end{array}$$

$$\begin{array}{r} 16 \\ + 9 \\ \hline \end{array}$$

$$\begin{array}{r} 5 \\ \times 5 \\ \hline \end{array}$$

$$\begin{array}{r} 8 \\ \times 3 \\ \hline \end{array}$$

$$\begin{array}{r} 33 \\ \times 8 \\ \hline \end{array}$$

$$\begin{array}{r} 8 \\ \times 7 \\ \hline \end{array}$$

$$\begin{array}{r} 56 \\ + 44 \\ \hline \end{array}$$

$$\begin{array}{r} 36 \\ \times 64 \\ \hline \end{array}$$

Bonus question: Shade  $\frac{1}{4}$  of each of the shapes below. Remember that fractions are divided into equal parts.

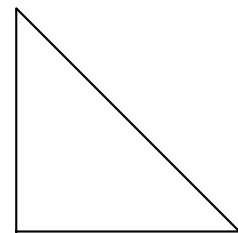
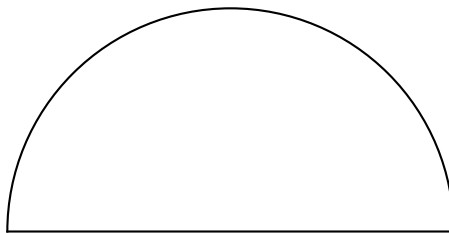
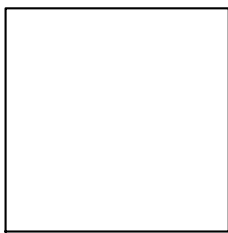

$$\begin{array}{r} 12 \\ \times 2 \\ \hline \end{array}$$

$$\begin{array}{r} 123 \\ \times 3 \\ \hline \end{array}$$

$$\begin{array}{r} 5 \\ \times 5 \\ \hline \end{array}$$

$$\begin{array}{r} 12 \\ \times 12 \\ \hline \end{array}$$

$$\begin{array}{r} 13 \\ \times 13 \\ \hline \end{array}$$

$$\begin{array}{r} 144 \\ + 25 \\ \hline \end{array}$$

$$\begin{array}{r} 4 \\ \times 5 \\ \hline \end{array}$$

$$\begin{array}{r} 20 \\ \times 5 \\ \hline \end{array}$$

$$\begin{array}{r} 6 \\ \times 4 \\ \hline \end{array}$$

$$\begin{array}{r} 9 \\ \times 5 \\ \hline \end{array}$$

$$\begin{array}{r} 7 \\ \times 3 \\ \hline \end{array}$$

$$\begin{array}{r} 77 \\ \times 3 \\ \hline \end{array}$$

$$\begin{array}{r} 9 \\ \times 6 \\ \hline \end{array}$$

$$\begin{array}{r} 180 \\ + 180 \\ \hline \end{array}$$

$$\begin{array}{r} 360 \\ \div 3 \\ \hline \end{array}$$

Bonus question: Four dwarves - Bofur, Bombur, Fili, and Kili - have four favorite numbers, four favorite ponies, and four different ages.

The favorite numbers are 3, 5, 6, and 12.

The ponies are named Trillium, Jack, Myrtle, and Pokey.

The ages of the dwarves are 81, 99, 121, and 144.

Figure out which dwarf has which pony, favorite number, and age from the clues below.

- Fili and Kili are the youngest of the dwarves.
- The number of letters in Bombur's pony's name is equal to his favorite number. Kili likes his pony for the same reason.
- The slowest pony, Pokey, is ridden by the oldest dwarf.
- Bofur's favorite number is evenly divisible by Fili and Kili's favorite numbers.
- Kili and Bofur's ages are both divisible by eleven.
- Fili likes his pony's name because it has the same number of letters as his name.

$$\begin{array}{r} 12 \\ \times 3 \\ \hline \end{array}$$

$$\begin{array}{r} 15 \\ \times 3 \\ \hline \end{array}$$

$$\begin{array}{r} 6 \\ \times 5 \\ \hline \end{array}$$

$$\begin{array}{r} 12 \\ \times 11 \\ \hline \end{array}$$

$$\begin{array}{r} 12 \\ \div 4 \\ \hline \end{array}$$

$$\begin{array}{r} 18 \\ \div 3 \\ \hline \end{array}$$

$$\begin{array}{r} 21 \\ \times 5 \\ \hline \end{array}$$

$$\begin{array}{r} 20 \\ \div 5 \\ \hline \end{array}$$

$$\begin{array}{r} 6 \\ \times 6 \\ \hline \end{array}$$

$$\begin{array}{r} 7 \\ \times 7 \\ \hline \end{array}$$

$$\begin{array}{r} 42 \\ \div 7 \\ \hline \end{array}$$

$$\begin{array}{r} 70 \\ \times 3 \\ \hline \end{array}$$

$$\begin{array}{r} 90 \\ \times 2 \\ \hline \end{array}$$

$$\begin{array}{r} 180 \\ \times 2 \\ \hline \end{array}$$

$$\begin{array}{r} 360 \\ \div 4 \\ \hline \end{array}$$

Bonus question: Get six six-sided die. Roll all of them six times - for each roll, write down the total of all the numbers.

If you were playing a game and could choose between getting 20 points or the total of six die rolls, which would you choose?

$16 + 16 =$

$100 + 25 =$

$16 + 48 =$

$7 \times 8 =$

$3 \times 9 =$

$32 \div 8 =$

$3^2 = 3 \times 3 =$

$3^3 = 3 \times 3 \times 3 =$

$2^3 =$

$4 \times 8 =$

$2^4 =$

$2^5 =$

$5^2 =$

$4^3 =$

$7^2 =$

$6^2 =$

$5^3 =$

$3^4 =$

Bonus question (you may need a little help): Make a Scratch program that adds up 100 random numbers from 1 to 6 and then shows the result.

$$\begin{array}{r} 7 \\ + 7 \\ \hline \end{array}$$

$$\begin{array}{r} 77 \\ + 77 \\ \hline \end{array}$$

$$\begin{array}{r} 1234 \\ + 777 \\ \hline \end{array}$$

$$\begin{array}{r} 7 \\ \times 6 \\ \hline \end{array}$$

$$\begin{array}{r} 105 \\ \div 7 \\ \hline \end{array}$$

- A) The interior angles of every triangle add up to  $180^\circ$ . In the triangle below, find the value of the third angle.

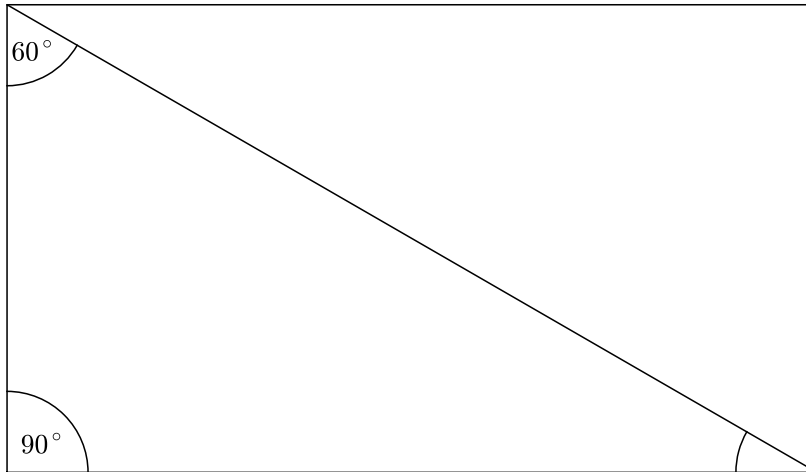

- B) In a rectangle, every interior angle is  $90^\circ$ . Using this fact, find the angles of the second triangle in the picture. Write your answer in the triangle.
- C) Using a ruler, measure the sides of the rectangle in inches and in centimeters. Label the sides of the rectangle with your results.
- D) Find a can of beans. Using a tape measure, measure the circumference (how far is it around the can). Then measure the diameter of the can. Finally, using a calculator, divide the circumference by the diameter.
- E) If you roll two six-sided die, how many ways can the numbers add up to 2? How many ways can they add up to 7?
- F) Lala is throwing a party, and she has invited 27 people (including herself and you). She can order tables that seat four people to a table. How many tables should she order?

$$\begin{array}{r} 7 \\ + 8 \\ \hline \end{array}$$

$$\begin{array}{r} 100 \\ - 85 \\ \hline \end{array}$$

$$\begin{array}{r} 9 \\ \times 7 \\ \hline \end{array}$$

$$\begin{array}{r} 40 \\ \times 30 \\ \hline \end{array}$$

$$\begin{array}{r} 120 \\ \div 4 \\ \hline \end{array}$$

$$\begin{array}{r} 7 \\ \times 8 \\ \hline \end{array}$$

$$\begin{array}{r} 10000 \\ - 1 \\ \hline \end{array}$$

$$\begin{array}{r} 12 \\ \times 12 \\ \hline \end{array}$$

$$\begin{array}{r} 13 \\ \times 13 \\ \hline \end{array}$$

$$\begin{array}{r} 125 \\ \div 5 \\ \hline \end{array}$$

These problems are about averages. People often use the word ‘average’ in a vague way, but in mathematics there are several kinds of averages.

The most important one is the *mean*: the mean of  $n$  numbers  $x_1, x_2, \dots, x_n$  is the sum of the numbers divided by  $n$ .

Example: The mean of 2, 12, and 4 is  $\frac{2+12+4}{3} = \frac{18}{3} = 6$ .

An easier kind of average to calculate is the *median*: if the numbers are arranged in order, the median is the middle value.

Example: The median of 2, 12, and 4 is 4, because it is the middle value.

- A) Find the mean and the median of 1, 2, 3.
  
  
  
  
  
  
  
  
  
  
- B) Find the mean and the median of 5, 5, 10, 10, and 90.
  
  
  
  
  
  
  
  
  
  
- C) Find the mean and median of 2, 1, 2, 1, 2, and 52.



$$\begin{array}{r} 5 \\ \times x \\ \hline 40 \end{array}$$

$$\begin{array}{r} 100 \\ - 85 \\ \hline \end{array}$$

$$\begin{array}{r} 9 \\ \times 7 \\ \hline \end{array}$$

$$\begin{array}{r} 40 \\ \times 30 \\ \hline \end{array}$$

$$\begin{array}{r} 120 \\ \div 4 \\ \hline \end{array}$$

$$\begin{array}{r} 7 \\ \times 8 \\ \hline \end{array}$$

$$\begin{array}{r} 10000 \\ - 1 \\ \hline \end{array}$$

$$\begin{array}{r} 12 \\ \times 12 \\ \hline \end{array}$$

$$\begin{array}{r} 13 \\ \times 13 \\ \hline \end{array}$$

$$\begin{array}{r} 125 \\ \div 5 \\ \hline \end{array}$$

A) If Annie, Durinda, Georgia, Jackie, Marcia, Petal, Rebecca, and Zinnia pay \$24 to get tickets for a play, how much does each ticket cost?

$$\begin{array}{r} 45 \\ + 46 \\ \hline \end{array}$$

$$\begin{array}{r} 101 \\ + 999 \\ \hline \end{array}$$

$$\begin{array}{r} 24 \\ + 68 \\ \hline \end{array}$$

$$\begin{array}{r} 49 \\ + 49 \\ \hline \end{array}$$

$$\begin{array}{r} 63 \\ + 99 \\ \hline \end{array}$$

$$\begin{array}{r} 4 \\ \times 4 \\ \hline \end{array}$$

$$\begin{array}{r} 5 \\ \times 5 \\ \hline \end{array}$$

$$\begin{array}{r} 6 \\ \times 6 \\ \hline \end{array}$$

$$\begin{array}{r} 7 \\ \times 7 \\ \hline \end{array}$$

$$\begin{array}{r} 360 \\ \div 18 \\ \hline \end{array}$$

Crazy bonus questions:

1. "Ohm's law" says that the voltage (V) in a circuit is related to the current (I) and the resistance (R) by the equation  $V = I \times R$ . If the voltage in our house is 120 (volts), and a lightbulb has a resistance of 60 (ohms), what is the current passing through it?
2. Try to pass Multiplication 2 on Khan Academy.

$$\begin{array}{r} 33 \\ 44 \\ + 55 \\ \hline \end{array}$$

$$\begin{array}{r} 123 \\ 456 \\ + 789 \\ \hline \end{array}$$

$$\begin{array}{r} 9 \\ 9 \\ + 9 \\ \hline \end{array}$$

$$\begin{array}{r} 27 \\ 27 \\ + 27 \\ \hline \end{array}$$

$$\begin{array}{r} 15 \\ 45 \\ + 40 \\ \hline \end{array}$$

$$\begin{array}{r} 3 \\ \times 4 \\ \hline \end{array}$$

$$\begin{array}{r} 5 \\ \times 6 \\ \hline \end{array}$$

$$\begin{array}{r} 6 \\ \times 7 \\ \hline \end{array}$$

$$\begin{array}{r} 7 \\ \times 8 \\ \hline \end{array}$$

$$\begin{array}{r} 540 \\ \div 6 \\ \hline \end{array}$$

Bonus:

1. Find out what the 100th triangular number  $1 + 2 + 3 + \dots + 100$  equals. Hint: Do not try to add them all up one by one! Think about how many pairs of equal sums there are ( $1 + 100$ ,  $2 + 99$ , etc).

2. Try to pass Telling Time on Khan Academy.

$$\begin{array}{r} 15 \\ + 15 \\ \hline \end{array}$$

$$\begin{array}{r} 17 \\ + 17 \\ \hline \end{array}$$

$$\begin{array}{r} 19 \\ + 19 \\ \hline \end{array}$$

$$\begin{array}{r} 100 \\ - 27 \\ \hline \end{array}$$

$$\begin{array}{r} 89 \\ + 89 \\ \hline \end{array}$$

$$\begin{array}{r} 6 \\ \times 8 \\ \hline \end{array}$$

$$\begin{array}{r} 6 \\ \times 6 \\ \hline \end{array}$$

$$\begin{array}{r} 6 \\ \times 7 \\ \hline \end{array}$$

$$\begin{array}{r} 6 \\ \times 4 \\ \hline \end{array}$$

$$\begin{array}{r} 2,500 \\ \div 5 \\ \hline \end{array}$$

$$\begin{array}{r} 23 \\ \times 2 \\ \hline \end{array}$$

$$\begin{array}{r} 17 \\ \times 2 \\ \hline \end{array}$$

$$\begin{array}{r} 21 \\ \times 10 \\ \hline \end{array}$$

$$\begin{array}{r} 21 \\ \times 5 \\ \hline \end{array}$$

$$\begin{array}{r} 252,525 \\ \div 5 \\ \hline \end{array}$$

Bonus:

1. Compute the 20th triangular number  $1+2+3+4+\dots+19+20$ . For long sums like this, mathematicians use the summand notation:

$$\sum_{n=1}^{20} n = 1 + 2 + 3 + 4 + \dots + 19 + 20$$

If you pair up numbers to make groups that total 21, you can turn this into a pretty easy multiplication problem.

$$\begin{array}{r} 15 \\ + 45 \\ \hline \end{array}$$

$$\begin{array}{r} 11001 \\ + 110 \\ \hline \end{array}$$

$$\begin{array}{r} 19 \\ \times 2 \\ \hline \end{array}$$

$$\begin{array}{r} 1000 \\ - 27 \\ \hline \end{array}$$

$$\begin{array}{r} 88 \\ \times 2 \\ \hline \end{array}$$

$$\begin{array}{r} 4 \\ \times 8 \\ \hline \end{array}$$

$$\begin{array}{r} 6 \\ \times 6 \\ \hline \end{array}$$

$$\begin{array}{r} 60 \\ \times 7 \\ \hline \end{array}$$

$$\begin{array}{r} 30 \\ \times 4 \\ \hline \end{array}$$

$$\begin{array}{r} 5,200 \\ \div 5 \\ \hline \end{array}$$

Bonus:

1. Fill out the table below for the five Platonic solids.

To figure out the number of edges, count the number of edges per face. Since each edge is shared by two faces, the total number of edges =

(the number of edges per face)  $\times$  (the number of faces)  $\div$  2.

For example, for a cube there are four edges per face, since each face is a square. There are six faces, so the number of edges is  $(4 \times 6) \div 2 = 24 \div 2 = 12$ .

Solid	Vertices	Edges	Faces
Tetrahedron			4
Cube	8	12	6
Octahedron			8
Dodecahedron			12
Icosahedron			20

$$\begin{array}{r} 15 \\ \times 7 \\ \hline \end{array}$$

$$\begin{array}{r} 3766 \\ + 1789 \\ \hline \end{array}$$

$$\begin{array}{r} 19 \\ \times 3 \\ \hline \end{array}$$

$$\begin{array}{r} 1000 \\ - 16 \\ \hline \end{array}$$

$$\begin{array}{r} 109 \\ \times 4 \\ \hline \end{array}$$

$$\begin{array}{r} 7 \\ \times 8 \\ \hline \end{array}$$

$$\begin{array}{r} 60 \\ \times 60 \\ \hline \end{array}$$

$$\begin{array}{r} 70 \\ \times 7 \\ \hline \end{array}$$

$$\begin{array}{r} 176 \\ \div 4 \\ \hline \end{array}$$

$$\begin{array}{r} 50,520 \\ \div 5 \\ \hline \end{array}$$

1. The population of the ten largest towns in St. Louis County, Minnesota, are:

Chisholm: 4,976

Duluth: 86,265

Eveleth: 3,718

Ely: 3,460

Hoyt Lakes: 2,017

Hermantown: 9,414

Hibbing: 16,361

Mountain Iron City: 2,869

Proctor: 3,057

Virginia: 8,712

Round the populations to the nearest thousand (for example, Aurora's population of 1,754 would be rounded to 2,000, and Babbitt's population of 1,475 would be rounded to 1,000). Then find the median population of these ten cities.

$$\begin{array}{r} 6 \\ \times 6 \\ \hline \end{array}$$

$$\begin{array}{r} 6 \\ \times 12 \\ \hline \end{array}$$

$$\begin{array}{r} 12 \\ \times 12 \\ \hline \end{array}$$

$$\begin{array}{r} 1000 \\ - 901 \\ \hline \end{array}$$

$$\begin{array}{r} 36 \\ \div 4 \\ \hline \end{array}$$

$$\begin{array}{r} 7 \\ \times 9 \\ \hline \end{array}$$

$$\begin{array}{r} 144 \\ \times 2 \\ \hline \end{array}$$

$$\begin{array}{r} 80 \\ \times 8 \\ \hline \end{array}$$

$$\begin{array}{r} 200 \\ \div 4 \\ \hline \end{array}$$

$$\begin{array}{r} 101 \\ + 909 \\ \hline \end{array}$$

Use the reference clocks to determine the times below. (Be careful when its close to an hour but not quite there yet!)

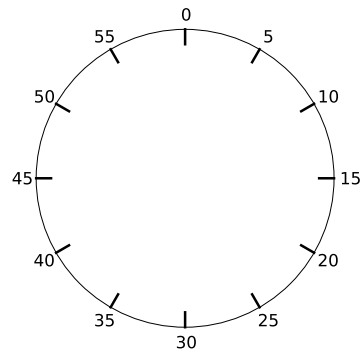
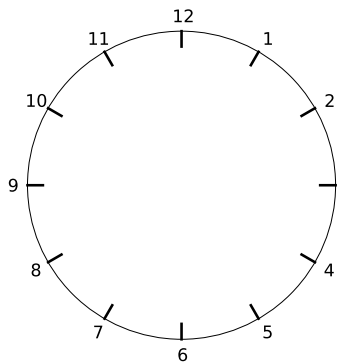

**Hello World in C**

To work up to doing a 'Hello, Pythagoras!' program in C, today you will write a 'Hello, World' program.

1. First, type the following code into TextMate and save it as 'Hello.c' in your 'HelloHoliday' folder. Remember that it is important to write it **exactly** the same.

```
#include <stdio.h>
main()
{
    printf("Hello World! \n");
}
```

2. Next, open the Terminal application. Go into your 'HelloHoliday' directory by typing `cd HelloHoliday`

3. Then you compile the program with the command

```
gcc -o HelloWorld hello.c
```

4. Finally you can run the program with

```
./HelloWorld
```

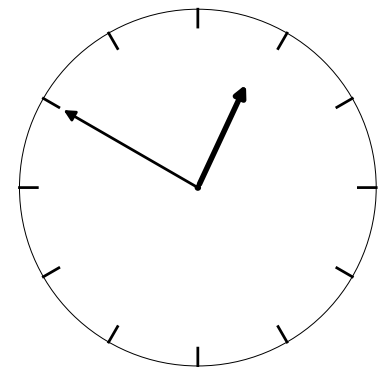
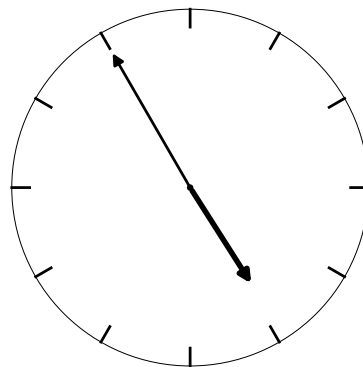

1.

2.

3.

$$\begin{array}{r} 7 \\ \times 7 \\ \hline \end{array}$$

$$\begin{array}{r} 12 \\ \times 7 \\ \hline \end{array}$$

$$\begin{array}{r} 28 \\ \div 7 \\ \hline \end{array}$$

$$\begin{array}{r} 76 \\ - 101 \\ \hline \end{array}$$

$$\begin{array}{r} 9 \\ \times 7 \\ \hline \end{array}$$

$$\begin{array}{r} 9 \\ \times 9 \\ \hline \end{array}$$

$$\begin{array}{r} 105 \\ \times 7 \\ \hline \end{array}$$

$$\begin{array}{r} 7 \\ \times 8 \\ \hline \end{array}$$

$$\begin{array}{r} 1484 \\ \div 7 \\ \hline \end{array}$$

$$\begin{array}{r} 688 \\ + 89 \\ \hline \end{array}$$

Determine the times below

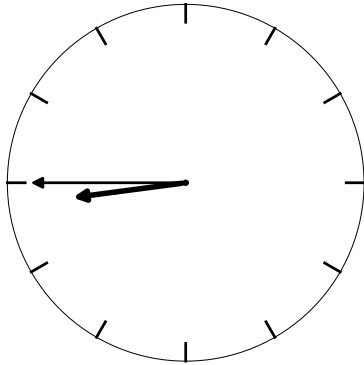

1.

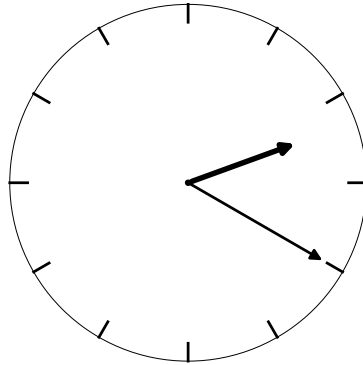

2.

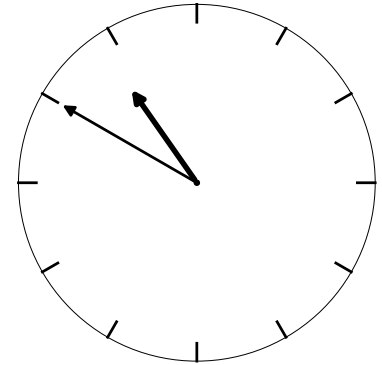

3.

4. At the top of a highrise apartment in Manhattan there lives a hungry monster named Frogbottom Bob. Frogbottom Bob eats a lot. Suppose Frogbottom Bob gets 100 pizzas delivered at noon. It takes him 6 hours to eat them all, and then he sleeps for another 6 hours. When he wakes up, he orders 100 more pizzas, but they take a half of an hour to arrive. If Frogbottom Bob always takes the same amount of time to eat, nap, and order pizzas, what time is it after he finishes his 300th pizza?



$$\begin{array}{r} 8 \\ \times 4 \\ \hline \end{array}$$

$$\begin{array}{r} 5 \\ \times 7 \\ \hline \end{array}$$

$$\begin{array}{r} 48 \\ + 96 \\ \hline \end{array}$$

$$\begin{array}{r} 72 \\ + 72 \\ \hline \end{array}$$

$$\begin{array}{r} 12 \\ \times 12 \\ \hline \end{array}$$

$$\begin{array}{r} 8 \\ \times 8 \\ \hline \end{array}$$

$$\begin{array}{r} 12 \\ \times 8 \\ \hline \end{array}$$

$$\begin{array}{r} 48 \\ \div 8 \\ \hline \end{array}$$

$$\begin{array}{r} 128 \\ + 128 \\ \hline \end{array}$$

$$\begin{array}{r} 80 \\ \times 7 \\ \hline \end{array}$$

$$\begin{array}{r} 24 \\ \times 3 \\ \hline \end{array}$$

$$\begin{array}{r} 8 \\ \times 9 \\ \hline \end{array}$$

$$\begin{array}{r} 128 \\ \div 8 \\ \hline \end{array}$$

$$\begin{array}{r} 256 \\ \div 16 \\ \hline \end{array}$$

$$\begin{array}{r} 799 \\ + 89 \\ \hline \end{array}$$

1. At the top of a highrise apartment in Manhattan there lives a hungry monster named Frogbottom Bob. Frogbottom Bob eats a lot. Lately Frogbottom Bob has been ordering 100 pizzas at a time, but he notices that this is pretty expensive. He usually orders from Scuzzy's Square Pizzas, and gets the Monster Supreme 16 inch Square Pizza. Each of these costs \$16.00. Today he notices that the Monster Supreme 11 inch Square Pizza is only \$ 8, so he could get two hundred 11 inch pizzas for the price of one hundred 16 inch pizzas. Would he get more pizza that way? (The area of a square with sides of length  $L$  is  $L \times L$ .)

$$\begin{array}{r} 8 \\ \times 2 \\ \hline \end{array}$$

$$\begin{array}{r} 4 \\ \times 4 \\ \hline \end{array}$$

$$\begin{array}{r} 16 \\ + 16 \\ \hline \end{array}$$

$$\begin{array}{r} 32 \\ + 32 \\ \hline \end{array}$$

$$\begin{array}{r} 8 \\ \times 4 \\ \hline \end{array}$$

$$\begin{array}{r} 8 \\ \times 8 \\ \hline \end{array}$$

$$\begin{array}{r} 64 \\ + 64 \\ \hline \end{array}$$

$$\begin{array}{r} 128 \\ \div 8 \\ \hline \end{array}$$

$$\begin{array}{r} 128 \\ + 128 \\ \hline \end{array}$$

$$\begin{array}{r} 80 \\ \times 5 \\ \hline \end{array}$$

$$\begin{array}{r} 2 \\ \times 9 \\ \hline \end{array}$$

$$\begin{array}{r} 8 \\ \times 3 \\ \hline \end{array}$$

$$\begin{array}{r} 128 \\ \div 16 \\ \hline \end{array}$$

$$\begin{array}{r} 256 \\ \div 16 \\ \hline \end{array}$$

$$\begin{array}{r} 256 \\ + 256 \\ \hline \end{array}$$

1. Add up the numbers

1,

1 + 2,

1 + 2 + 4,

1 + 2 + 4 + 8,

... can you find a pattern?

$$\begin{array}{r} 15 \\ + 6 \\ \hline \end{array}$$

$$\begin{array}{r} 3 \\ \times 2 \\ \hline \end{array}$$

$$\begin{array}{r} 6 \\ \times 4 \\ \hline \end{array}$$

$$\begin{array}{r} 24 \\ \times 5 \\ \hline \end{array}$$

$$\begin{array}{r} 120 \\ \times 6 \\ \hline \end{array}$$

$$\begin{array}{r} 21 \\ + 7 \\ \hline \end{array}$$

$$\begin{array}{r} 28 \\ + 8 \\ \hline \end{array}$$

$$\begin{array}{r} 512 \\ + 512 \\ \hline \end{array}$$

$$\begin{array}{r} 1024 \\ + 1024 \\ \hline \end{array}$$

$$2^{10} =$$

1. Frogbottom Bob is thinking about ordering something different from Scuzzy's Square Pizza. His favorite toppings are olives (O), pepperoni (P), banana peppers (B), and sausage (S). Bob tries to count up all of the ways he could order two of those four toppings. He thinks there are six different combinations that use two toppings each. Do you think he is correct? Try to write down all the combinations.

2. Frogbottom Bob then remembers he also likes ordering extra cheese (E). He can only afford to order pizzas with two toppings, and extra cheese counts as a topping. Now he would like to know how many kinds of two-topping pizzas there are that use his five favorite toppings. He is worried that he won't count all of these correctly so he calls up his friend, Vera the Vampire. Vera listens to the problem, but she is in a bad mood and all she says is, "Bob, you know Pascal's Triangle, right? Just write that down and it will tell you the answer". Then she hangs up. Bob is pretty depressed since she is his only real friend but he tries to remember Pascal's Triangle. He remembers that there are 1s all along the sides, and each number in the triangle is the sum of the two numbers above it.

Bob writes down the beginning of Pascal's Triangle. He doesn't know how it answers his pizza question, so he starts looking for patterns. One thing he tries is to add up all the numbers in each row of the triangle. Help out Bob by adding another two rows to the triangle and totalling each row.

total						
	1			1		
	2		1		1	
		1	2		1	
		1	3	3	1	
		1	4	6	4	1

(1) Find all the numbers less than 100 which are multiples of only 3 and 5. For example, three of them are 3, 5, and 15. But 21 is not such a number, since it is a multiple of 7 and 3.

(2) Use the circle below to answer the following question: if Jack eats  $\frac{1}{3}$  of a pie, and Jill eats  $\frac{1}{4}$  of the pie, how much of the pie is left for Juliet? (You might want to color in the portions eaten by Jack and Jill).

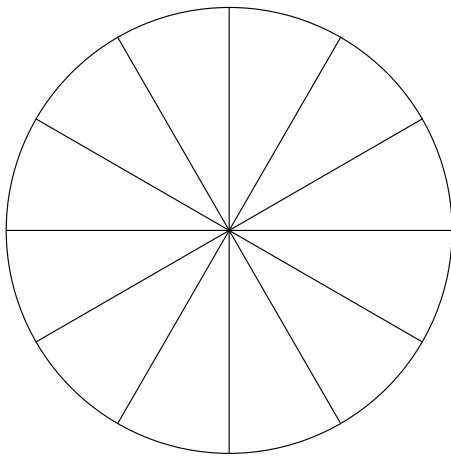

$$\begin{array}{r} 7 \\ \times 2 \\ \hline \end{array}$$

$$\begin{array}{r} 14 \\ \times 4 \\ \hline \end{array}$$

$$\begin{array}{r} 7 \\ \times 8 \\ \hline \end{array}$$

$$\begin{array}{r} 24 \\ \times 3 \\ \hline \end{array}$$

$$\begin{array}{r} 9 \\ \times 8 \\ \hline \end{array}$$

$$\begin{array}{r} 27 \\ \times 3 \\ \hline \end{array}$$

$$\begin{array}{r} 36 \\ + 64 \\ \hline \end{array}$$

$$\begin{array}{r} 6 \\ \times 6 \\ \hline \end{array}$$

$$\begin{array}{r} 8 \\ \times 8 \\ \hline \end{array}$$

$$\begin{array}{r} 144 \\ \div 8 \\ \hline \end{array}$$

$$\begin{array}{r} 3 \\ \times 2 \\ \hline \end{array}$$

$$\begin{array}{r} 6 \\ \times 4 \\ \hline \end{array}$$

$$\begin{array}{r} 7 \\ + 8 \\ \hline \end{array}$$

$$\begin{array}{r} 12 \\ \div 3 \\ \hline \end{array}$$

$$\begin{array}{r} 9 \\ + 8 \\ \hline \end{array}$$

$$\begin{array}{r} 3 \\ \times 4 \\ \hline \end{array}$$

$$\begin{array}{r} 6 \\ + 4 \\ \hline \end{array}$$

$$\begin{array}{r} 6 \\ \times 3 \\ \hline \end{array}$$

$$\begin{array}{r} 7 \\ \times 3 \\ \hline \end{array}$$

$$\begin{array}{r} 12 \\ + 21 \\ \hline \end{array}$$

$$\begin{array}{r} 27 \\ + 3 \\ \hline \end{array}$$

$$\begin{array}{r} 7 \\ \times 7 \\ \hline \end{array}$$

$$\begin{array}{r} 6 \\ \times 6 \\ \hline \end{array}$$

$$\begin{array}{r} 4 \\ \times 8 \\ \hline \end{array}$$

$$\begin{array}{r} 14 \\ + 8 \\ \hline \end{array}$$

$$\begin{array}{r} 9 \\ + 3 \\ \hline \end{array}$$

$$\begin{array}{r} 15 \\ + 16 \\ \hline \end{array}$$

$$\begin{array}{r} 135 \\ + 45 \\ \hline \end{array}$$

$$\begin{array}{r} 5 \\ \times 3 \\ \hline \end{array}$$

$$\begin{array}{r} 1 \\ + 3 \\ \hline \end{array}$$

$$\begin{array}{r} 13 \\ \times 2 \\ \hline \end{array}$$

$$\begin{array}{r} 22 \\ + 88 \\ \hline \end{array}$$

$$\begin{array}{r} 50 \\ + 60 \\ \hline \end{array}$$

$$\begin{array}{r} 12 \\ \div 4 \\ \hline \end{array}$$

$$\begin{array}{r} 19 \\ + 18 \\ \hline \end{array}$$

$$\begin{array}{r} 210 \\ \div 2 \\ \hline \end{array}$$

$$\begin{array}{r} 105 \\ \div 5 \\ \hline \end{array}$$

$$\begin{array}{r} 210 \\ \div 7 \\ \hline \end{array}$$

$$\begin{array}{r} 7 \\ \times 7 \\ \hline \end{array}$$

$$\begin{array}{r} 15 \\ \times 5 \\ \hline \end{array}$$

$$\begin{array}{r} 45 \\ + 15 \\ \hline \end{array}$$

$$\begin{array}{r} 8 \\ \times 7 \\ \hline \end{array}$$

$$\begin{array}{r} 6 \\ \times 8 \\ \hline \end{array}$$

$$\begin{array}{r} 3 \\ \times 8 \\ \hline \end{array}$$

$$\begin{array}{r} 321 \\ + 123 \\ \hline \end{array}$$

$$\begin{array}{r} 9 \\ + 4 \\ \hline \end{array}$$

$$\begin{array}{r} 105 \\ + 107 \\ \hline \end{array}$$

$$\begin{array}{r} 270 \\ + 90 \\ \hline \end{array}$$

$$\begin{array}{r} 5 \\ \times 5 \\ \hline \end{array}$$

$$\begin{array}{r} 1 \\ + 1 \\ \hline \end{array}$$

Its pretty easy to check if a number is divisible by three: if you add the digits together, the sum must also be divisible by three.

For example, lets check if 1,452 is divisible by three. Since  $1 + 4 + 5 + 2 = 12$ , and twelve is divisible by three, we see that 1,452 is divisible by three.

Use this nice property to color in all the hexagons in Pascal's triangle which have numbers divisible by three.

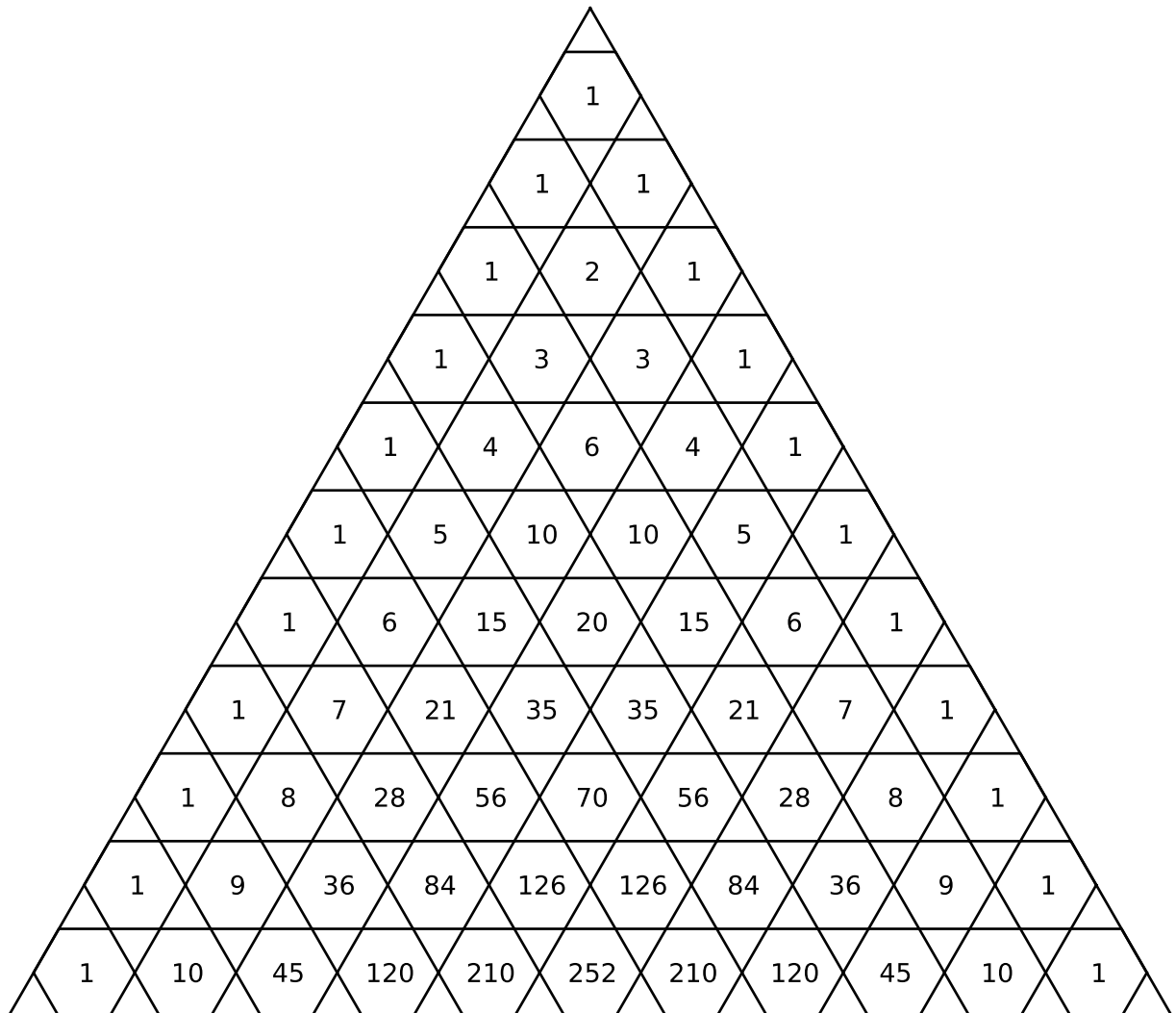



$$\begin{array}{r} 30 \\ + 20 \\ \hline \end{array}$$

$$\begin{array}{r} 26 \\ - 8 \\ \hline \end{array}$$

$$\begin{array}{r} 7 \\ + 8 \\ \hline \end{array}$$

$$\begin{array}{r} 12 \\ \div 3 \\ \hline \end{array}$$

$$\begin{array}{r} 91 \\ + 81 \\ \hline \end{array}$$

Complete the multiplication table below:  
( $2 \times 3 = 6$  is done for you as an example.)

times	2	5	6	10	11
3	6				
4					
7					
8					
9					
12					

$$\begin{array}{r} 30 \\ \times 2 \\ \hline \end{array}$$

$$\begin{array}{r} 6 \\ \times 4 \\ \hline \end{array}$$

$$\begin{array}{r} 71 \\ + 81 \\ \hline \end{array}$$

$$\begin{array}{r} 12 \\ \div 3 \\ \hline \end{array}$$

$$\begin{array}{r} 9 \\ + 8 \\ \hline \end{array}$$

$$\begin{array}{r} 3 \\ \times 4 \\ \hline \end{array}$$

$$\begin{array}{r} 62 \\ + 48 \\ \hline \end{array}$$

$$\begin{array}{r} 6 \\ \times 3 \\ \hline \end{array}$$

$$\begin{array}{r} 7 \\ \times 3 \\ \hline \end{array}$$

$$\begin{array}{r} 112 \\ + 121 \\ \hline \end{array}$$

$$\begin{array}{r} 27 \\ + 3 \\ \hline \end{array}$$

$$\begin{array}{r} 7 \\ \times 7 \\ \hline \end{array}$$

$$\begin{array}{r} 6 \\ \times 6 \\ \hline \end{array}$$

$$\begin{array}{r} 4 \\ \times 8 \\ \hline \end{array}$$

$$\begin{array}{r} 14 \\ + 8 \\ \hline \end{array}$$

$$\begin{array}{r} 9 \\ \times 3 \\ \hline \end{array}$$

$$\begin{array}{r} 19 \\ + 16 \\ \hline \end{array}$$

$$\begin{array}{r} 135 \\ + 45 \\ \hline \end{array}$$

$$\begin{array}{r} 5 \\ \times 12 \\ \hline \end{array}$$

$$\begin{array}{r} 11 \\ \times 3 \\ \hline \end{array}$$

Challenge question:

Find all the numbers less than 30 which are multiples of only 2 and/or 3. For example, the smallest three of them are 2, 3, and 6 ( $= 2 \times 3$ ). (There are eight others besides those three.)

$$\begin{array}{r} 55 \\ \times 2 \\ \hline \end{array}$$

$$\begin{array}{r} 8 \\ \times 8 \\ \hline \end{array}$$

$$\begin{array}{r} 233 \\ + 377 \\ \hline \end{array}$$

$$\begin{array}{r} 21 \\ \div 3 \\ \hline \end{array}$$

$$\begin{array}{r} 13 \\ + 8 \\ \hline \end{array}$$

$$\begin{array}{r} 8 \\ \times 5 \\ \hline \end{array}$$

$$\begin{array}{r} 55 \\ + 34 \\ \hline \end{array}$$

$$\begin{array}{r} 8 \\ \times 3 \\ \hline \end{array}$$

$$\begin{array}{r} 21 \\ \times 3 \\ \hline \end{array}$$

$$\begin{array}{r} 144 \\ + 233 \\ \hline \end{array}$$

$$\begin{array}{r} 1 \\ 2 \\ + 5 \\ \hline \end{array}$$

$$\begin{array}{r} 2 \\ 3 \\ \times 5 \\ \hline \end{array}$$

$$\begin{array}{r} 13 \\ \times 8 \\ \hline \end{array}$$

$$\begin{array}{r} 4 \\ \times 9 \\ \hline \end{array}$$

$$\begin{array}{r} 55 \\ + 89 \\ \hline \end{array}$$

A question on bunnies:

Eight hundred years ago, a man called Fibonacci thought about bunnies, and how older bunnies become parents and make more bunnies. His famous model of bunny love says that to find the total number of bunnies each month, you add the number of bunnies that were there in the previous two months. If we start with 1 bunny in month 1, and 1 bunny in month 2, then there will be  $1 + 1 = 2$  bunnies in month three.

These are called the Fibonacci numbers, and the first few are:

$$F_1 = 1, F_2 = 1, F_3 = 2, F_4 = 3, F_5 = 5, F_6 = 8, F_7 = 13, F_8 = 21.$$

The next one would be  $F_9 = F_8 + F_7 = 21 + 13 = 34$ .

Can you find a pattern in which Fibonacci numbers are odd and which are even?

times	2	3	7	8	9
3					
4					
5					
6					
9					

Suppose you are making a necklace out of beads, and you have some large beads and some small beads. You decide you will use a pattern of:  
 small-small-large-small-small-large-...

You have two colors of large beads (red and blue), and three colors of small beads (green, purple, and black). How many color choices do you have if you repeat them in the pattern? (For example, one choice would be green-green-red, and another would be purple-green-blue.)

$$\begin{array}{r} 32 \\ \times 2 \\ \hline \end{array}$$

$$\begin{array}{r} 28 \\ \div 7 \\ \hline \end{array}$$

$$\begin{array}{r} 700 \\ \div 7 \\ \hline \end{array}$$

$$\begin{array}{r} 36 \\ \div 3 \\ \hline \end{array}$$

$$\begin{array}{r} 14 \\ + 21 \\ \hline \end{array}$$

$$\begin{array}{r} 7 \\ \times 5 \\ \hline \end{array}$$

$$\begin{array}{r} 70 \\ + 35 \\ \hline \end{array}$$

$$\begin{array}{r} 6 \\ \times 7 \\ \hline \end{array}$$

$$\begin{array}{r} 21 \\ \times 5 \\ \hline \end{array}$$

$$\begin{array}{r} 105 \\ + 35 \\ \hline \end{array}$$

$$\begin{array}{r} 22 \\ 33 \\ + 55 \\ \hline \end{array}$$

$$\begin{array}{r} 2 \\ 3 \\ \times 7 \\ \hline \end{array}$$

$$\begin{array}{r} 15 \\ \times 7 \\ \hline \end{array}$$

$$\begin{array}{r} 7 \\ \times 9 \\ \hline \end{array}$$

$$\begin{array}{r} 14 \\ + 56 \\ \hline \end{array}$$

$$\begin{array}{r} 728 \\ + 4 \\ \hline \end{array}$$

$$\begin{array}{r} 3 \\ \times 5 \\ \hline \end{array}$$

$$\begin{array}{r} 12 \\ \times 8 \\ \hline \end{array}$$

$$\begin{array}{r} 4 \\ \times 9 \\ \hline \end{array}$$

$$\begin{array}{r} 56 \\ + 89 \\ \hline \end{array}$$

$$\begin{array}{r} 180 \\ \times 2 \\ \hline \end{array}$$

$$\begin{array}{r} 90 \\ \div 2 \\ \hline \end{array}$$

$$\begin{array}{r} 90 \\ \div 9 \\ \hline \end{array}$$

$$\begin{array}{r} 60 \\ \div 3 \\ \hline \end{array}$$

$$\begin{array}{r} 24 \\ + 36 \\ \hline \end{array}$$

$$\begin{array}{r} 27 \\ \times 5 \\ \hline \end{array}$$

$$\begin{array}{r} 72 \\ + 108 \\ \hline \end{array}$$

$$\begin{array}{r} 6 \\ \times 8 \\ \hline \end{array}$$

$$\begin{array}{r} 12 \\ \times 5 \\ \hline \end{array}$$

$$\begin{array}{r} 105 \\ + 75 \\ \hline \end{array}$$

$$\begin{array}{r} 36 \\ 72 \\ + 72 \\ \hline \end{array}$$

$$\begin{array}{r} 6 \\ 6 \\ \times 10 \\ \hline \end{array}$$

$$\begin{array}{r} 60 \\ \div 4 \\ \hline \end{array}$$

$$\begin{array}{r} 60 \\ \div 12 \\ \hline \end{array}$$

$$\begin{array}{r} 28 \\ + 49 \\ \hline \end{array}$$

You will need a straightedge (a ruler for example) for this problem. Choose a point on the semicircle. Draw straight lines from the corners of the semicircle to that point, forming a triangle. What is the angle of the triangle at the point you chose?

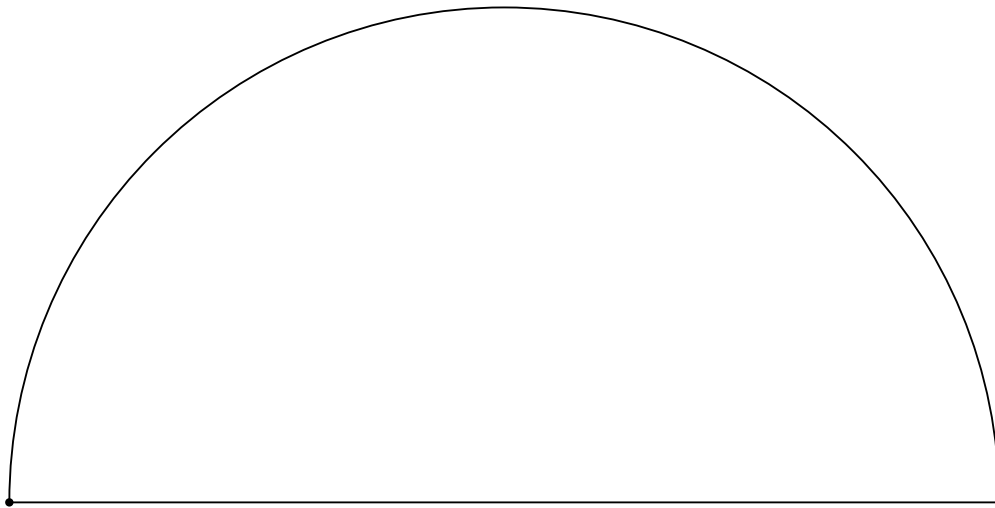

$$\begin{array}{r} 800 \\ \div 8 \\ \hline \end{array}$$

$$\begin{array}{r} 32 \\ \div 4 \\ \hline \end{array}$$

$$\begin{array}{r} 832 \\ \div 4 \\ \hline \end{array}$$

$$\begin{array}{r} 11 \\ \div 10 \\ \hline \end{array}$$

$$\begin{array}{r} 35 \\ + 35 \\ \hline \end{array}$$

$$\begin{array}{r} 63 \\ - 7 \\ \hline \end{array}$$

$$\begin{array}{r} 246 \\ + 975 \\ \hline \end{array}$$

$$\begin{array}{r} 8 \\ \times 7 \\ \hline \end{array}$$

$$\begin{array}{r} 8 \\ \times 17 \\ \hline \end{array}$$

$$\begin{array}{r} 360 \\ - 270 \\ \hline \end{array}$$

$$\begin{array}{r} 10 \\ 11 \\ + 12 \\ \hline \end{array}$$

$$\begin{array}{r} 6 \\ 5 \\ \times 5 \\ \hline \end{array}$$

$$\begin{array}{r} 11 \\ \times 3 \\ \hline \end{array}$$

$$\begin{array}{r} 10000 \\ - 1 \\ \hline \end{array}$$

$$\begin{array}{r} 2.27 \\ - 2.03 \\ \hline \end{array}$$

1. What is  $\frac{1}{2} + \frac{1}{4}$  ?

2. What is  $\frac{1}{2} + \frac{1}{3}$  ?

3. What is  $\frac{1}{2} + \frac{1}{4} + \frac{1}{8}$  ?

$$\begin{array}{r} 12 \\ \div 3 \\ \hline \end{array}$$

$$\begin{array}{r} 12 \\ \div 4 \\ \hline \end{array}$$

$$\begin{array}{r} 728 \\ \div 7 \\ \hline \end{array}$$

$$\begin{array}{r} 110 \\ \div 10 \\ \hline \end{array}$$

$$\begin{array}{r} 100 \\ - 64 \\ \hline \end{array}$$

$$\begin{array}{r} 70 \\ - 7 \\ \hline \end{array}$$

$$\begin{array}{r} 999,999 \\ + 1 \\ \hline \end{array}$$

$$\begin{array}{r} 9 \\ \times 7 \\ \hline \end{array}$$

$$\begin{array}{r} 13 \\ \times 13 \\ \hline \end{array}$$

$$\begin{array}{r} 144 \\ \div 12 \\ \hline \end{array}$$

What is  $\frac{1}{3} + \frac{1}{4}$ ? (Hint: draw a circle into quarters, then divide each quarter into three pieces.)



$$\begin{array}{r} 132 \\ \div 11 \\ \hline \end{array}$$

$$\begin{array}{r} 77 \\ + 55 \\ \hline \end{array}$$

$$\begin{array}{r} 12 \\ \times 11 \\ \hline \end{array}$$

$$\begin{array}{r} 330 \\ \div 11 \\ \hline \end{array}$$

$$\begin{array}{r} 100 \\ - 36 \\ \hline \end{array}$$

$$\begin{array}{r} 70 \\ - 14 \\ \hline \end{array}$$

$$\begin{array}{r} 999,999 \\ + 2 \\ \hline \end{array}$$

$$\begin{array}{r} 9 \\ \times 5 \\ \hline \end{array}$$

$$\begin{array}{r} 13 \\ \times 9 \\ \hline \end{array}$$

$$\begin{array}{r} 156 \\ \div 12 \\ \hline \end{array}$$

1. Was ist neun plus fünf?
2. Was ist zwölf plus elf?
3. Was ist drei mal vier multipliziert?

$$\begin{array}{r} 89 \\ + 98 \\ \hline \end{array}$$

$$\begin{array}{r} 9999 \\ \div 11 \\ \hline \end{array}$$

$$\begin{array}{r} 9 \\ \times 12 \\ \hline \end{array}$$

$$\begin{array}{r} 125 \\ \div 5 \\ \hline \end{array}$$

$$\begin{array}{r} 100 \\ - 48 \\ \hline \end{array}$$

$$\begin{array}{r} 70 \\ - 42 \\ \hline \end{array}$$

$$\begin{array}{r} 999,999 \\ - 999,899 \\ \hline \end{array}$$

$$\begin{array}{r} 7 \\ \times 7 \\ \hline \end{array}$$

$$\begin{array}{r} 9 \\ \times 9 \\ \hline \end{array}$$

$$\begin{array}{r} -14 \\ \times 3 \\ \hline \end{array}$$

1. Was ist sieben plus vier?
2. Was ist sechs mal zehn multipliziert?
3. Was ist acht mal acht multipliziert?

$$\begin{array}{r} 13 \\ + 13 \\ \hline \end{array}$$

$$\begin{array}{r} 52 \\ \div 13 \\ \hline \end{array}$$

$$\begin{array}{r} 9 \\ \times 13 \\ \hline \end{array}$$

$$\begin{array}{r} 169 \\ \div 13 \\ \hline \end{array}$$

$$\begin{array}{r} 100 \\ - 13 \\ \hline \end{array}$$

$$\begin{array}{r} 91 \\ - 42 \\ \hline \end{array}$$

$$\begin{array}{r} 1000 \\ - 987 \\ \hline \end{array}$$

$$\begin{array}{r} 13 \\ \times 7 \\ \hline \end{array}$$

$$\begin{array}{r} 13 \\ \times 5 \\ \hline \end{array}$$

$$\begin{array}{r} 15 \\ \times 12 \\ \hline \end{array}$$

Twelves: 12, 24, 36, 48, 60, 72, 84, 96, 108, 120

Fifteens: 15, 30, 45, 60, 75, 90, 105, 120, 135, 150

1. Using the lists above, find the smallest number that is a multiple of both 15 and 12.
2. What is  $2 \times 2 \times 3 \times 5$ ?
3. What is the smallest number that is a multiple of both 6 and 10?

$$\begin{array}{r} 18 \\ + 18 \\ \hline \end{array}$$

$$\begin{array}{r} 24 \\ \times 3 \\ \hline \end{array}$$

$$\begin{array}{r} 72 \\ \div 8 \\ \hline \end{array}$$

$$\begin{array}{r} 143 \\ \div 13 \\ \hline \end{array}$$

$$\begin{array}{r} 123 \\ - 25 \\ \hline \end{array}$$

$$\begin{array}{r} 10 \\ - 7 \\ \hline \end{array}$$

$$\begin{array}{r} 100 \\ - 87 \\ \hline \end{array}$$

$$\begin{array}{r} 3 \\ \times 7 \\ \hline \end{array}$$

$$\begin{array}{r} 20 \\ \times 5 \\ \hline \end{array}$$

$$\begin{array}{r} 5 \\ \times 8 \\ \hline \end{array}$$

1. If  $Z - 2 = 10$ , what is  $Z$ ?

$$\begin{array}{r} 19 \\ + 17 \\ \hline \end{array}$$

$$\begin{array}{r} 32 \\ \times 3 \\ \hline \end{array}$$

$$\begin{array}{r} 72 \\ \div 9 \\ \hline \end{array}$$

$$\begin{array}{r} 260 \\ \div 13 \\ \hline \end{array}$$

$$\begin{array}{r} 1001 \\ - 110 \\ \hline \end{array}$$

$$\begin{array}{r} 123,456,789 \\ - 12,345,567 \\ \hline \end{array}$$

$$\begin{array}{r} 101 \\ - 76 \\ \hline \end{array}$$

$$\begin{array}{r} 50 \\ \times 5 \\ \hline \end{array}$$

$$\begin{array}{r} 50 \\ \times 50 \\ \hline \end{array}$$

$$\begin{array}{r} 15 \\ \times 8 \\ \hline \end{array}$$

1. If  $Z - 5 = 15$ , what is  $Z$ ?

2. If  $3Z = 15$ , what is  $Z$ ?

3. If  $Z \div 10 = 10$ , what is  $Z$ ?

4. If  $Z + 1 = 2 - Z$ , what is  $Z$ ?

$$\begin{array}{r} 5 \\ \times 5 \\ \hline \end{array}$$

$$\begin{array}{r} 50 \\ \times 5 \\ \hline \end{array}$$

$$\begin{array}{r} 500 \\ \times 2 \\ \hline \end{array}$$

$$\begin{array}{r} 500 \\ \times 5 \\ \hline \end{array}$$

$$\begin{array}{r} 64 \\ - 48 \\ \hline \end{array}$$

$$\begin{array}{r} 999,999,999 \\ - 12,345,678 \\ \hline \end{array}$$

$$\begin{array}{r} 102 \\ - 77 \\ \hline \end{array}$$

$$\begin{array}{r} 60 \\ \div 6 \\ \hline \end{array}$$

$$\begin{array}{r} 3600 \\ \div 6 \\ \hline \end{array}$$

$$\begin{array}{r} 22 \\ \times 5 \\ \hline \end{array}$$

$$\begin{array}{r} 9 \\ \times 4 \\ \hline \end{array}$$

$$\begin{array}{r} 4 \\ \times 8 \\ \hline \end{array}$$

$$\begin{array}{r} 7 \\ \times 7 \\ \hline \end{array}$$

$$\begin{array}{r} 6 \\ \times 6 \\ \hline \end{array}$$

$$\begin{array}{r} 3 \\ \times 3 \\ \hline \end{array}$$

The problems below are about averages. The two most common ways to average a set of numbers are using the: *mean*, where you add up all the numbers and divide by how many there are, and the *median*, where you sort the numbers and then pick the middle value.

Here is an example: if the numbers are 5, 4, 1, 10, and 100, then

$$\text{mean} = \frac{5 + 4 + 1 + 10 + 100}{5} = \frac{120}{5} = 24.$$

The median is 5, since it is the middle number once they are sorted: 1, 4, 5, 10, 100.

1. Suppose Mary has 1 dollar, Sam has 1 dollar, Jack has no dollars, Wilma has 8 dollars, and Barbu has 100 dollars. What is the mean number of dollars for these five people? What is the median number of dollars?

$$\begin{array}{r} 12 \\ \times 5 \\ \hline \end{array}$$

$$\begin{array}{r} 12 \\ \times 12 \\ \hline \end{array}$$

$$\begin{array}{r} 123 \\ \times 4 \\ \hline \end{array}$$

$$\begin{array}{r} 500 \\ - 5 \\ \hline \end{array}$$

$$\begin{array}{r} 96 \\ - 48 \\ \hline \end{array}$$

$$\begin{array}{r} 100,000,001 \\ - 3 \\ \hline \end{array}$$

$$\begin{array}{r} 100 \\ - 11 \\ \hline \end{array}$$

$$\begin{array}{r} 17 \\ + 43 \\ \hline \end{array}$$

$$\begin{array}{r} 720 \\ \div 6 \\ \hline \end{array}$$

$$\begin{array}{r} 7 \\ \times 3 \\ \hline \end{array}$$

1. Was ist vier plus sechs?

2. Number riddle: I am a number, less than 100. If you divide me by 6, you get an even number. If you divide me by 12, you get an odd number. I end in a zero.

3. What is  $\frac{1}{2} + \frac{2}{3}$ ? (Hint: how many sixths is  $\frac{1}{2}$ ? How many sixths is  $\frac{2}{3}$ ?)

$$\begin{array}{r} 3 \\ \times 4 \\ \hline \end{array}$$

$$\begin{array}{r} 2 \\ \times 6 \\ \hline \end{array}$$

$$\begin{array}{r} 321 \\ \times 4 \\ \hline \end{array}$$

$$\begin{array}{r} 5.23 \\ - 2.28 \\ \hline \end{array}$$

$$\begin{array}{r} 128 \\ - 64 \\ \hline \end{array}$$

$$\begin{array}{r} 100 \\ \times 10 \\ \hline \end{array}$$

$$\begin{array}{r} 100 \\ \times 100 \\ \hline \end{array}$$

$$\begin{array}{r} 274 \\ + 777 \\ \hline \end{array}$$

$$\begin{array}{r} 720 \\ \div 6 \\ \hline \end{array}$$

$$\begin{array}{r} 6 \\ \times 7 \\ \hline \end{array}$$

1. What is  $\frac{2}{3} + \frac{3}{4}$ ? Use the two circles below to help (count the twelfths):

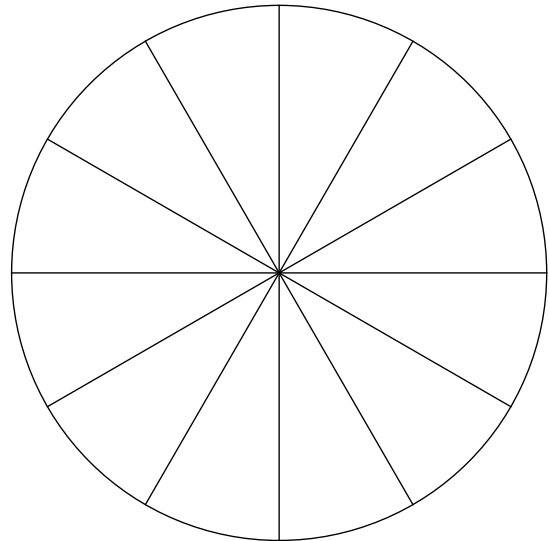
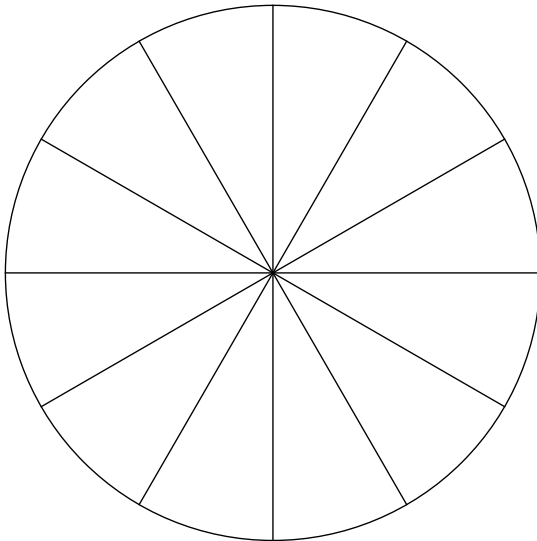



$$\begin{array}{r} 3 \\ \times 5 \\ \hline \end{array}$$

$$\begin{array}{r} 13 \\ \times 5 \\ \hline \end{array}$$

$$\begin{array}{r} 117 \\ \div 9 \\ \hline \end{array}$$

$$\begin{array}{r} 1.37 \\ - 0.38 \\ \hline \end{array}$$

$$\begin{array}{r} 1024 \\ - 512 \\ \hline \end{array}$$

$$\begin{array}{r} 100 \\ \times 11 \\ \hline \end{array}$$

$$\begin{array}{r} 100 \\ \times 111 \\ \hline \end{array}$$

$$\begin{array}{r} 6 \\ + 595 \\ \hline \end{array}$$

$$\begin{array}{r} 336 \\ \div 7 \\ \hline \end{array}$$

$$\begin{array}{r} 4 \\ \times 7 \\ \hline \end{array}$$

1. Number riddle: I am a number, less than twenty. If you divided me by 5, you would get a remainder of 3. If you divided me by 3, you would get a remainder of 1. In German, I begin with a 'd'.

2. What is  $\frac{1}{3} + \frac{1}{5}$ ? (Hint: use the smallest common multiple of 3 and 5.)

$$\begin{array}{r} 24 \\ \times 5 \\ \hline \end{array}$$

$$\begin{array}{r} 6 \\ \times 6 \\ \hline \end{array}$$

$$\begin{array}{r} 120 \\ \div 3 \\ \hline \end{array}$$

$$\begin{array}{r} 2 \\ - 0.25 \\ \hline \end{array}$$

$$\begin{array}{r} 2048 \\ - 1023 \\ \hline \end{array}$$

$$\begin{array}{r} 11 \\ \times 11 \\ \hline \end{array}$$

$$\begin{array}{r} 1000 \\ \times 1000 \\ \hline \end{array}$$

$$\begin{array}{r} 26 \\ + 77 \\ \hline \end{array}$$

$$\begin{array}{r} 8 \\ \times 4 \\ \hline \end{array}$$

$$\begin{array}{r} 336 \\ \div 8 \\ \hline \end{array}$$

1. Number riddle: I am a number, less than forty. If you divided me by 7, you would get a remainder of 6. If you divided me by 3, you would get a remainder of 2. In German, I begin with a 'z'.

2. What is  $\frac{1}{3} + \frac{1}{6}$ ?

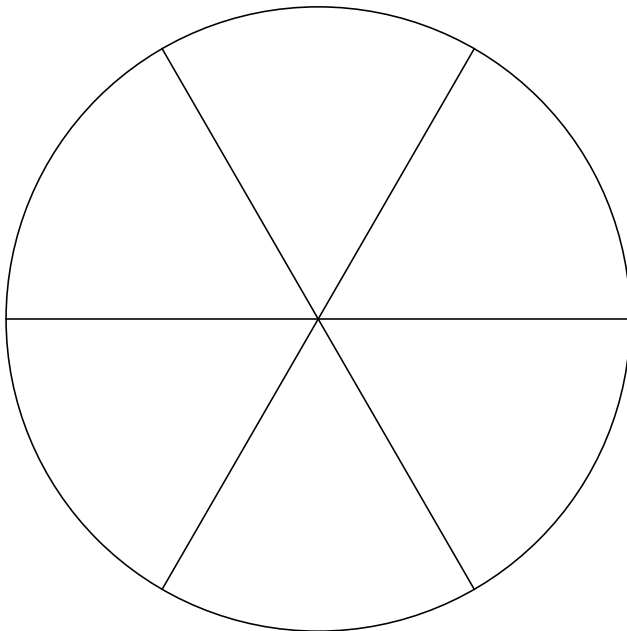

$$\begin{array}{r} 144 \\ \times 2 \\ \hline \end{array}$$

$$\begin{array}{r} 144 \\ \times 5 \\ \hline \end{array}$$

$$\begin{array}{r} 360 \\ \div 3 \\ \hline \end{array}$$

$$\begin{array}{r} 1.75 \\ + 0.25 \\ \hline \end{array}$$

$$\begin{array}{r} 4096 \\ - 2048 \\ \hline \end{array}$$

$$\begin{array}{r} 12 \\ \times \frac{1}{2} \\ \hline \end{array}$$

$$\begin{array}{r} 101 \\ \times 1000 \\ \hline \end{array}$$

$$\begin{array}{r} 55 \\ + 84 \\ \hline \end{array}$$

$$\begin{array}{r} 40 \\ \times 9 \\ \hline \end{array}$$

$$\begin{array}{r} 360 \\ \div 12 \\ \hline \end{array}$$

1. What is  $\frac{1}{5} + \frac{1}{10}$ ?

2. If you turn in a full circle, you go around 360 degrees. If you walked in a five-pointed star, you end up turning around twice. Since  $360 + 360 = 720$ , at each point of the star you need to turn  $720 \div 5$  degrees.

Write a Scratch program using the turn, move, repeat, and pen down commands to draw a five-pointed star.

$$\begin{array}{r} 80 \\ \times 9 \\ \hline \end{array}$$

$$\begin{array}{r} 32 \\ \times 5 \\ \hline \end{array}$$

$$\begin{array}{r} 360 \\ \div 8 \\ \hline \end{array}$$

$$\begin{array}{r} 1.75 \\ \div 0.25 \\ \hline \end{array}$$

$$\begin{array}{r} 8192 \\ - 4096 \\ \hline \end{array}$$

$$\begin{array}{r} 15 \\ \times \frac{1}{3} \\ \hline \end{array}$$

$$\begin{array}{r} 100 \\ \times \frac{1}{10} \\ \hline \end{array}$$

$$\begin{array}{r} 55 \\ + 89 \\ \hline \end{array}$$

$$\begin{array}{r} 160 \\ \times 9 \\ \hline \end{array}$$

$$\begin{array}{r} 120 \\ \div 15 \\ \hline \end{array}$$

1. What is  $\frac{1}{3} + \frac{2}{15}$ ?

2. Can you modify your Scratch program to make a nine-pointed star? Hint:  $360 \div 9 = 40$ , and the angle you need to turn is a multiple of that.

$$\begin{array}{r} 180 \\ \times 3 \\ \hline \end{array}$$

$$\begin{array}{r} 24 \\ \times 5 \\ \hline \end{array}$$

$$\begin{array}{r} 360 \\ \div 12 \\ \hline \end{array}$$

$$\begin{array}{r} 1.00 \\ \div 0.05 \\ \hline \end{array}$$

$$\begin{array}{r} 16384 \\ - 8192 \\ \hline \end{array}$$

$$\begin{array}{r} 15 \\ \times \frac{1}{5} \\ \hline \end{array}$$

$$\begin{array}{r} 100 \\ \times \frac{2}{100} \\ \hline \end{array}$$

$$\begin{array}{r} 144 \\ + 89 \\ \hline \end{array}$$

$$\begin{array}{r} 250 \\ \times 8 \\ \hline \end{array}$$

$$\begin{array}{r} 120 \\ \div 30 \\ \hline \end{array}$$

1. What is  $\frac{1}{6} + \frac{1}{4}$ ?

$$\begin{array}{r} 5 \\ \times 5 \\ \hline \end{array}$$

$$\begin{array}{r} 6 \\ \times 4 \\ \hline \end{array}$$

$$\begin{array}{r} 7 \\ \times 3 \\ \hline \end{array}$$

$$\begin{array}{r} 8 \\ \times 2 \\ \hline \end{array}$$

$$\begin{array}{r} 9 \\ \times 1 \\ \hline \end{array}$$

$$\begin{array}{r} 6 \\ \times 6 \\ \hline \end{array}$$

$$\begin{array}{r} 7 \\ \times 5 \\ \hline \end{array}$$

$$\begin{array}{r} 8 \\ \times 4 \\ \hline \end{array}$$

$$\begin{array}{r} 9 \\ \times 3 \\ \hline \end{array}$$

$$\begin{array}{r} 10 \\ \times 2 \\ \hline \end{array}$$

$$\begin{array}{r} 9 \\ \times 9 \\ \hline \end{array}$$

$$\begin{array}{r} 10 \\ \times 8 \\ \hline \end{array}$$

$$\begin{array}{r} 11 \\ \times 7 \\ \hline \end{array}$$

$$\begin{array}{r} 12 \\ \times 6 \\ \hline \end{array}$$

$$\begin{array}{r} 13 \\ \times 5 \\ \hline \end{array}$$

$$\begin{array}{r} 80 \\ - 77 \\ \hline \end{array}$$

$$\begin{array}{r} 24 \\ - 21 \\ \hline \end{array}$$

$$\begin{array}{r} 32 \\ - 27 \\ \hline \end{array}$$

$$\begin{array}{r} 16 \\ - 9 \\ \hline \end{array}$$

$$\begin{array}{r} 72 \\ - 65 \\ \hline \end{array}$$

1. There is a pattern to the questions in the first three rows. Is there a pattern in the answers?

$$\begin{array}{r} 180 \\ \div 3 \\ \hline \end{array}$$

$$\begin{array}{r} 36 \\ \times 5 \\ \hline \end{array}$$

$$\begin{array}{r} 15 \\ \times 24 \\ \hline \end{array}$$

$$\begin{array}{r} 360 \\ \div 15 \\ \hline \end{array}$$

$$\begin{array}{r} 32768 \\ - 16384 \\ \hline \end{array}$$

$$\begin{array}{r} 32 \\ \times \frac{1}{4} \\ \hline \end{array}$$

$$\begin{array}{r} \frac{1}{4} \\ \times \frac{1}{4} \\ \hline \end{array}$$

$$\begin{array}{r} 144 \\ - 89 \\ \hline \end{array}$$

$$\begin{array}{r} 125 \\ \times 8 \\ \hline \end{array}$$

$$\begin{array}{r} 1024 \\ \div 4 \\ \hline \end{array}$$

1. What is  $\frac{1}{4} + \frac{2}{5}$ ?

2. The divisors of a number are all of the numbers that divide it with no remainder. Usually we just use the positive divisors.

For example, the positive divisors of 12 are 1, 2, 3, 4, 6, and 12.

What are the positive divisors of 10?

$$\begin{array}{r} 360 \\ \div 4 \\ \hline \end{array}$$

$$\begin{array}{r} 18 \\ \times 5 \\ \hline \end{array}$$

$$\begin{array}{r} 15 \\ \times 5 \\ \hline \end{array}$$

$$\begin{array}{r} 210 \\ \div 6 \\ \hline \end{array}$$

$$\begin{array}{r} 65536 \\ \div 2 \\ \hline \end{array}$$

$$\begin{array}{r} 32 \\ \times \frac{1}{8} \\ \hline \end{array}$$

$$\begin{array}{r} \frac{1}{2} \\ \times \frac{1}{3} \\ \hline \end{array}$$

$$\begin{array}{r} 256 \\ - 128 \\ \hline \end{array}$$

$$\begin{array}{r} 75 \\ \times 4 \\ \hline \end{array}$$

$$\begin{array}{r} 1024 \\ \div 8 \\ \hline \end{array}$$

1. The children Victoria, Wanda, Xavier, Yves, and Zelda each have some pets. The pets are 4 frogs, 1 dog, 9 mice, 16 hermit crabs, and 50 fireflies. The ages of the children are 8, 10, 12, 13, and 15. Figure out which kid has which pet and age from the clues below:
- Zelda's age is only one less than the number of her pets.
  - Xavier likes extremes - he wanted to have either the most or the fewest pets.
  - The same boy is the median age and has the median number of pets.
  - Wanda likes numbers, and she likes that her both her age and number of pets are multiples of 2. Her only regret is that the number of her pets is not the mean or the median.
  - Victoria thinks the other kids have weird pets. She was talking to Wanda and Zelda and said, 'You should have chosen a mammal like I did!'.
  - Zelda is older than Wanda or Victoria. Their ages are both Fibonacci numbers though.



$$\begin{array}{r} 720 \\ \div 4 \\ \hline \end{array}$$

$$\begin{array}{r} 17 \\ \times 5 \\ \hline \end{array}$$

$$\begin{array}{r} 9 \\ \times 5 \\ \hline \end{array}$$

$$\begin{array}{r} 210 \\ \div 7 \\ \hline \end{array}$$

$$\begin{array}{r} 65536 \\ \div 4 \\ \hline \end{array}$$

$$\begin{array}{r} 32 \\ \div 16 \\ \hline \end{array}$$

$$\begin{array}{r} \frac{1}{2} \\ \times 3 \\ \hline \end{array}$$

$$\begin{array}{r} 196 \\ - 128 \\ \hline \end{array}$$

$$\begin{array}{r} 12 \\ \times \frac{3}{4} \\ \hline \end{array}$$

$$\begin{array}{r} 75 \\ \times 12 \\ \hline \end{array}$$

The distributive law says that for any three numbers  $a$ ,  $b$ , and  $c$ ,

$$a \times (b + c) = a \times b + a \times c$$

This can be useful sometimes. For example, to calculate  $5 \times 995$ , we could do

$$\begin{array}{r} 995 \\ \times 5 \\ \hline 25 \\ 450 \\ +4500 \\ \hline 4975 \end{array}$$

or we could do

$$5 \times 995 = 5 \times (1000 - 5) = 5 \times 1000 - 5 \times 5 = 5000 - 25 = 4975.$$

1. Use the distributive law to calculate  $3 \times 9998$ .

$$\begin{array}{r} 720 \\ \div 6 \\ \hline \end{array}$$

$$\begin{array}{r} 21 \\ \times 5 \\ \hline \end{array}$$

$$\begin{array}{r} 8 \\ \times 6 \\ \hline \end{array}$$

$$\begin{array}{r} 210 \\ \div 5 \\ \hline \end{array}$$

$$\begin{array}{r} 65536 \\ \div 8 \\ \hline \end{array}$$

$$\begin{array}{r} 32 \\ \div 4 \\ \hline \end{array}$$

$$\begin{array}{r} \frac{2}{5} \\ + \frac{2}{3} \\ \hline \end{array}$$

$$\begin{array}{r} 243 \\ \div 3 \\ \hline \end{array}$$

$$\begin{array}{r} 12 \\ \times 0.75 \\ \hline \end{array}$$

$$\begin{array}{r} 5 \\ \times 3 \\ \hline \end{array}$$

Fill in the blank:

1.  $5 \times 995 = 5 \times \underline{\quad} - 5 \times 5$

2.  $1.25 = \frac{\quad}{4}$



(1) If I eat half of a pumpkin pie, and you eat a third of a pumpkin pie, and mom eats a sixth of a pumpkin pie, how much pie is left over?

(2) We have about 140 pieces of candy to give out for Halloween. How many pieces per child should we hand out if a total of 30 kids come to our house?

(3) At four pm this evening the temperature is predicted to be 41 °Fahrenheit. Convert this to degrees Celsius by first subtracting 32 and then multiplying by  $\frac{5}{9}$ . (For example, water boils at 212°F. First we subtract 32:  $212 - 32 = 180$ . Then we multiply by  $\frac{5}{9}$  to get  $180 \times \frac{5}{9} = 100^\circ\text{C}$ .)

$$\begin{array}{r} 60 \\ \div 5 \\ \hline \end{array}$$

$$\begin{array}{r} 25 \\ \times 5 \\ \hline \end{array}$$

$$\begin{array}{r} 25 \\ \times 4 \\ \hline \end{array}$$

$$\begin{array}{r} 2.5 \\ \times 4 \\ \hline \end{array}$$

$$\begin{array}{r} 0.25 \\ \times 4 \\ \hline \end{array}$$

$$\begin{array}{r} 0.4 \\ \times 25 \\ \hline \end{array}$$

$$\begin{array}{r} \frac{2}{5} \\ + \frac{3}{5} \\ \hline \end{array}$$

$$\begin{array}{r} 81 \\ \div 3 \\ \hline \end{array}$$

$$\begin{array}{r} 12 \\ \times 0.25 \\ \hline \end{array}$$

$$\begin{array}{r} 15 \\ \div 3 \\ \hline \end{array}$$

Fill in the blank:

1. If I have 135 party favors and 25 people come to my party, how many party favors should I give out to each person?
2. If 25 people buy a giant chocolate bunny for \$140 dollars, how much should each person pay?
3. Which is larger, 1.5 or  $\frac{7}{5}$ ?

$$\begin{array}{r} 60 \\ \div 6 \\ \hline \end{array}$$

$$\begin{array}{r} 15 \\ \times 5 \\ \hline \end{array}$$

$$\begin{array}{r} 33 \\ \times 3 \\ \hline \end{array}$$

$$\begin{array}{r} 13 \\ \times 13 \\ \hline \end{array}$$

$$\begin{array}{r} 50 \\ - 4 \\ \hline \end{array}$$

$$\begin{array}{r} 180 \\ - 45 \\ \hline \end{array}$$

$$\begin{array}{r} \frac{12}{15} \\ + \frac{18}{15} \\ \hline \end{array}$$

$$\begin{array}{r} 231 \\ \div 3 \\ \hline \end{array}$$

$$\begin{array}{r} 12 \\ \times 12 \\ \hline \end{array}$$

$$\begin{array}{r} 45 \\ \div 3 \\ \hline \end{array}$$

1. A *rhombus* has four sides of the same length. If all of the interior angles are 90 degrees, then its a square. Turned on their points they are often called diamonds. Write a Scratch program that draws a rhombus. Can you make it so it could draw any shape of rhombus? (The shape is determined by the length of a side and one angle. Two angles in a row have to add up to 180 degrees.)

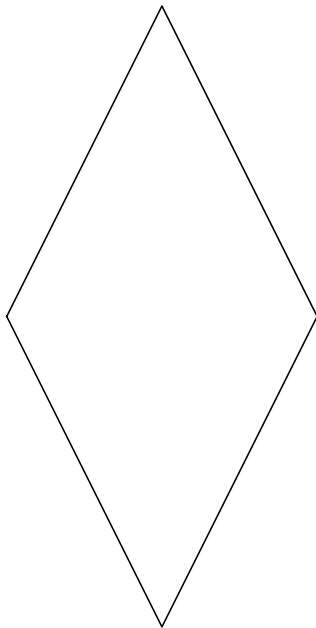

$$\begin{array}{r} 8 \\ \times 1 \\ \hline \end{array}$$

$$\begin{array}{r} 88 \\ \times 11 \\ \hline \end{array}$$

$$\begin{array}{r} 888 \\ \times 111 \\ \hline \end{array}$$

$$\begin{array}{r} 11 \\ \times 11 \\ \hline \end{array}$$

$$\begin{array}{r} 12321 \\ \div 111 \\ \hline \end{array}$$

$$\begin{array}{r} 180 \\ - 72 \\ \hline \end{array}$$

$$\begin{array}{r} \frac{12}{15} \\ + \frac{18}{15} \\ \hline \end{array}$$

$$\begin{array}{r} 231 \\ \div 7 \\ \hline \end{array}$$

$$\begin{array}{r} 14 \\ \times 14 \\ \hline \end{array}$$

$$\begin{array}{r} 108 \\ \div 2 \\ \hline \end{array}$$

1. Play the  $3n + 1$  game with the number 53. (If its odd, triple it and add one; if its even, divide by two.) Write down all the steps!

2. The interior angles of a triangle add up to 180 degrees. The isosceles triangle below has two angles equal to  $A$  and one equal to 36 degrees. What is  $A$ ?

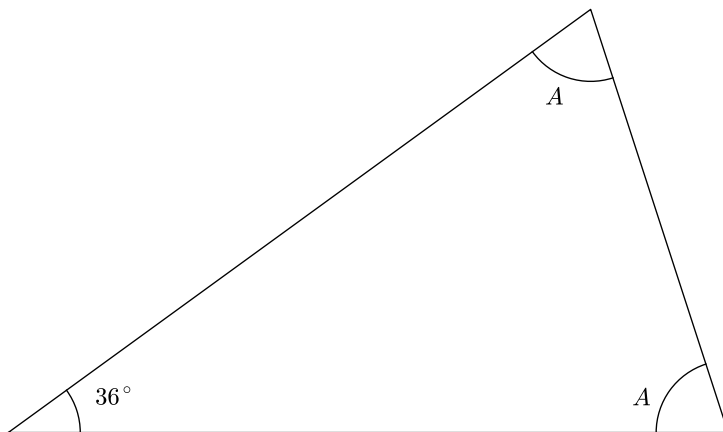

$$\begin{array}{r} 8 \\ \times 3 \\ \hline \end{array}$$

$$\begin{array}{r} 88 \\ \div 11 \\ \hline \end{array}$$

$$\begin{array}{r} 100 \\ \times 0.01 \\ \hline \end{array}$$

$$\begin{array}{r} 12 \\ \times 9 \\ \hline \end{array}$$

$$\begin{array}{r} 1234321 \\ \div 1111 \\ \hline \end{array}$$

$$\begin{array}{r} 5^2 \\ - 4^2 \\ \hline \end{array}$$

$$\begin{array}{r} \frac{17}{15} \\ + \frac{28}{15} \\ \hline \end{array}$$

$$\begin{array}{r} \sqrt{64} \\ \div \sqrt{4} \\ \hline \end{array}$$

$$\begin{array}{r} 15 \\ \times 15 \\ \hline \end{array}$$

$$\begin{array}{r} 108 \\ \div 9 \\ \hline \end{array}$$

1. The chart below shows the expected number of graduating high school seniors in Minnesota from 2010 until 2023.

a) If you graduate from high school when you are 18 years old, about how many other high school graduates will there be in Minnesota?

b) Without doing the full calculation, estimate the mean (average) number of high school graduates in Minnesota over this time period (2010-2023).

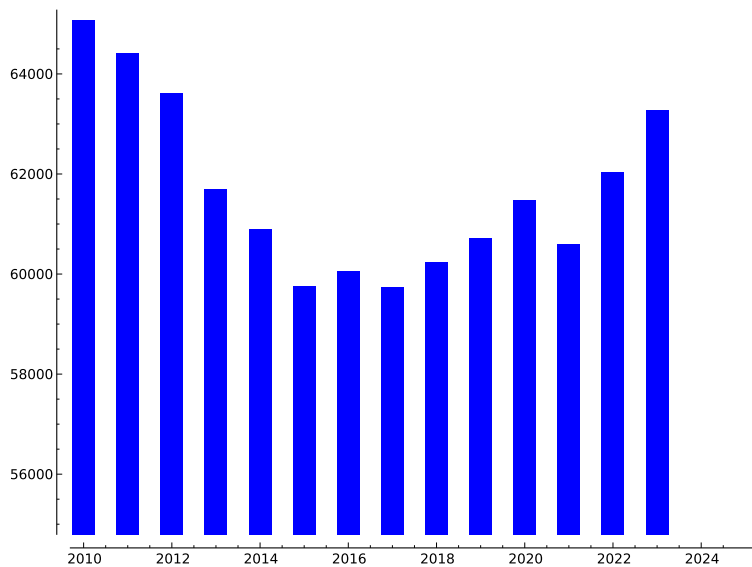

1. What is  $2 \times 2 \times 4$ ?
2. What is  $1050 \times 1000$ ?
3. If  $12 \times m = 36$ , what is  $m$ ?
4. What's 117 divided by 9?
5. What is 0.01 more than 2.5?
6. What is  $\frac{2}{3} - \frac{1}{4}$  ?
7. How many minutes are in an hour?
8. How many minutes are in a day?
9.  $24 = 2^3 \times 3$ . Can you factor 36 in a similar way?
10. There are two cups in a pint. There are two pints in a quart. There are four quarts in a gallon. How many cups are in a gallon?



1. If  $12 \times m = 132$ , what is  $m$ ?
2. If you are dealt a card from a normal (52-card) deck, what is the chance that you get a spade? What is the simplest way to write that answer (hint: there are four suits in a deck)?
3. What's 126 divided by 9?
4. What is  $1^3 + 3^3 + 5^3$ ?
5. What is  $\frac{2}{5} - \frac{2}{4}$  ?
6. If a fathom is six feet, how many inches is a fathom?
7. What is  $100 \times 200$ ?
8. The weights of gems are sometimes measured in points or carats. Each point is 2 mg (mg=milligrams, so a point is 2 thousandths of a gram). There are a hundred points in a carat. A *paragon diamond* is a flawless diamond weighing at least 100 carats. How many grams must a paragon diamond weigh?
9. What is the perimeter of an octagon if each side is 8 inches long?

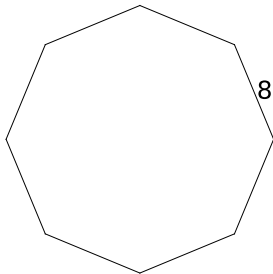

1. If  $2 \times m = 3 + m$ , what is  $m$ ?
2. If you flip a coin twice, what is the chance that you get two heads?
3. If you flip a coin twice, what is the chance that you get a head and a tail (in either order)?
4. What is  $1^1 + 7^2 + 5^3$ ?
5. What is  $\frac{5}{4} - \frac{4}{5}$ ?
6. If you had a nicely stacked pile of wood that was 8 feet wide and 4 feet deep and 4 feet high, you would have a *cord* of wood. This means there are  $8 \times 4 \times 4$  cubic feet in a cord. How many cubic feet is that?
7. What is  $2^7$ ?
8.  $\pi$  cannot be written as a fraction. It is approximately 3.14159. What is  $\pi$  rounded to the nearest tenth?
9. The interior angles of a triangle add up to 180 degrees. If you added up all the interior angles of an octagon how many degrees would it be?

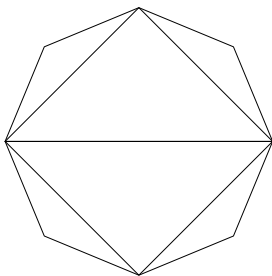

$$\begin{array}{r} 8 \\ \times 7 \\ \hline \end{array}$$

$$\begin{array}{r} 9 \\ \times 5 \\ \hline \end{array}$$

$$\begin{array}{r} 9 \\ \times 6 \\ \hline \end{array}$$

$$\begin{array}{r} 9 \\ \times 7 \\ \hline \end{array}$$

$$\begin{array}{r} 12 \\ \times 9 \\ \hline \end{array}$$

$$\begin{array}{r} 36 \\ \div 4 \\ \hline \end{array}$$

$$\begin{array}{r} 225 \\ \div 15 \\ \hline \end{array}$$

$$\begin{array}{r} 49 \\ \div 7 \\ \hline \end{array}$$

$$\begin{array}{r} 16 \\ \times 16 \\ \hline \end{array}$$

$$\begin{array}{r} 117 \\ \div 9 \\ \hline \end{array}$$

1. The sum of the internal angles of a triangle is 180 degrees. What is the sum of the internal angles of a rectangle?
2. The distance between two bases on a standard baseball field is 90 feet. What is the perimeter of a baseball diamond?
3. You are helping to plan a party and need to know how much it will cost. The ballroom will cost \$100 no matter how many people show up. Each person that shows up will cost \$4.50. Can you write a Scratch program that asks how many people will show up and then says how much the cost of the party will be?

$$\begin{array}{r} 8 \\ \times 5 \\ \hline \end{array}$$

$$\begin{array}{r} 9 \\ \times 4 \\ \hline \end{array}$$

$$\begin{array}{r} 144 \\ \div 12 \\ \hline \end{array}$$

$$\begin{array}{r} 14 \\ \times 3 \\ \hline \end{array}$$

$$\begin{array}{r} 22 \\ \times 11 \\ \hline \end{array}$$

$$\begin{array}{r} 360 \\ \div 3 \\ \hline \end{array}$$

$$\begin{array}{r} 120 \\ \div 3 \\ \hline \end{array}$$

$$\begin{array}{r} 40 \\ \div 4 \\ \hline \end{array}$$

$$\begin{array}{r} 2 \\ \times 5 \\ \hline \end{array}$$

$$\begin{array}{r} 126 \\ \div 9 \\ \hline \end{array}$$

1. The sum of the internal angles of a pentagon is 540 degrees. What is the sum of the external angles of a pentagon?
2. Can you write 360 as a product of powers of 2, 3, and 5? (Hint:  $36 = 2^2 \times 3^2$ .)
3. Shown below are two sketches of a hexagonal prism. Can you sketch a pentagonal prism?

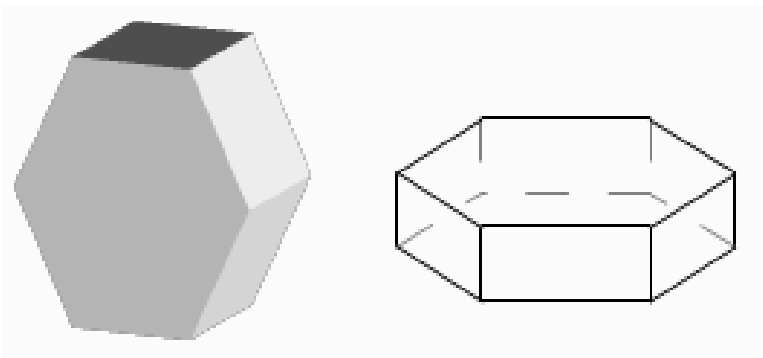

$$\begin{array}{r} 18 \\ \times 5 \\ \hline \end{array}$$

$$\begin{array}{r} 45 \\ \times 8 \\ \hline \end{array}$$

$$\begin{array}{r} 144 \\ \div 3 \\ \hline \end{array}$$

$$\begin{array}{r} 14 \\ \times 4 \\ \hline \end{array}$$

$$\begin{array}{r} 101 \\ \times 101 \\ \hline \end{array}$$

$$\begin{array}{r} 360 \\ \div 15 \\ \hline \end{array}$$

$$\begin{array}{r} 3 \\ \frac{4}{6} \\ \hline \end{array}$$

$$\begin{array}{r} 484 \\ \div 4 \\ \hline \end{array}$$

$$\begin{array}{r} 222 \\ \times 5 \\ \hline \end{array}$$

$$\begin{array}{r} 135 \\ \div 9 \\ \hline \end{array}$$

1. Which is larger, 1.5 or  $\frac{18}{12}$ ?

2. Which is larger, 1.5 or  $\frac{19}{12}$ ?

3.  $48 = 3 \times 2^{\square}$  (fill in the missing exponent).

$$\begin{array}{r} 6 \\ \times 4 \\ \hline \end{array}$$

$$\begin{array}{r} 24 \\ \times 5 \\ \hline \end{array}$$

$$\begin{array}{r} 120 \\ \times 6 \\ \hline \end{array}$$

$$\begin{array}{r} 14 \\ \times 5 \\ \hline \end{array}$$

$$\begin{array}{r} 101 \\ \times 99 \\ \hline \end{array}$$

$$\begin{array}{r} 360 \\ \div 5 \\ \hline \end{array}$$

$$\begin{array}{r} 0.85 \\ + 0.15 \\ \hline \end{array}$$

$$\begin{array}{r} 480 \\ \div 8 \\ \hline \end{array}$$

$$\begin{array}{r} 333 \\ \times 5 \\ \hline \end{array}$$

$$\begin{array}{r} 144 \\ \div 9 \\ \hline \end{array}$$

1. Factorials: the notation  $n!$  means  $n \times (n - 1) \times \dots \times 1$ .

For example,  $5! = 5 \times 4 \times 3 \times 2 \times 1 = 120$ .

Compute  $6!$ .

2. Can you write a Scratch program that computes factorials? (As a test of your program, it should say that  $10! = 3628800$ .)

3. In geometry we say that two things are *similar* if they are the same shape, but not necessarily the same size. The two triangles shown below are similar. Can you figure out how long the hypotenuse of the smaller triangle is?

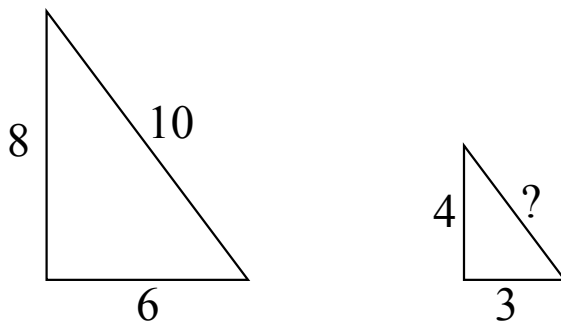

$$\begin{array}{r} 6 \\ \times 7 \\ \hline \end{array}$$

$$\begin{array}{r} 24 \\ \div 4 \\ \hline \end{array}$$

$$\begin{array}{r} 120 \\ \div 5 \\ \hline \end{array}$$

$$\begin{array}{r} 15 \\ \times 5 \\ \hline \end{array}$$

$$\begin{array}{r} 105 \\ \times 95 \\ \hline \end{array}$$

$$\begin{array}{r} 365 \\ \div 5 \\ \hline \end{array}$$

$$\begin{array}{r} 0.09 \\ + 1.15 \\ \hline \end{array}$$

$$\begin{array}{r} 136 \\ \div 8 \\ \hline \end{array}$$

$$\begin{array}{r} 81 \\ \times 3 \\ \hline \end{array}$$

$$\begin{array}{r} 243 \\ \div 3 \\ \hline \end{array}$$

1. What is  $\frac{1}{2} + \frac{1}{4} + \frac{1}{8}$  ?

Here are some examples of logarithms:

$$\log_2(8) = \log_2(2^3) = 3.$$

$$\log_3(27) = \log_3(3^3) = 3.$$

$$\log_{10}(100) = \log_{10}(10^2) = 2$$

$$\text{and } \log_{10}(1000) = 3$$

2. What do you think  $\log_{10}(10000) =$  ?

$$\begin{array}{r} 14 \\ \times 3 \\ \hline \end{array}$$

$$\begin{array}{r} 8 \\ \times 7 \\ \hline \end{array}$$

$$\begin{array}{r} 40 \\ \times 4 \\ \hline \end{array}$$

$$\begin{array}{r} 1039 \\ - 997 \\ \hline \end{array}$$

$$\begin{array}{r} 40 \\ \times 40 \\ \hline \end{array}$$

$$\begin{array}{r} 210 \\ \div 5 \\ \hline \end{array}$$

$$\begin{array}{r} 13 \\ \times 14 \\ \hline \end{array}$$

$$\begin{array}{r} 20.19 \\ + 21.81 \\ \hline \end{array}$$

$$\begin{array}{r} 729 \\ \div 9 \\ \hline \end{array}$$

$$\begin{array}{r} 294 \\ \div 7 \\ \hline \end{array}$$

1. What is  $\sqrt{1764}$ ?
2. At 11:47 am mom puts some banana-apple bread in the oven. If it takes 55 minutes to bake the bread, at what time should she take it out of the oven?
3. Consider the pattern of dots below. The first figure has two dots; how many dots would the sixth figure have? How about the 10th figure?

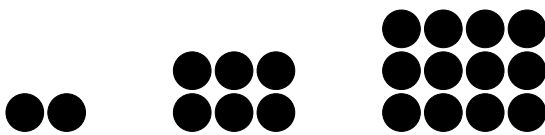



1.  $\frac{1}{2} + \frac{1}{4} =$

2.  $\frac{1}{2} + \frac{1}{4} + \frac{1}{8} =$

3.  $\frac{1}{2} + \frac{1}{4} + \frac{1}{8} + \frac{1}{16} =$

4. Use the pattern in problems 1,2, and 3 to guess an answer to

$$\frac{1}{2} + \frac{1}{4} + \frac{1}{8} + \frac{1}{16} + \frac{1}{32} + \frac{1}{64} + \frac{1}{128} =$$

5. If you have a rectangle whose perimeter is 36 inches, how long and wide is the rectangle?

6. What is the mean (average) of the list of the numbers: 1, 1, 4, 6?

7. Which number is larger,  $\frac{1}{3}$  or 0.26?

8. Here is the factorization of 24:  $24 = 2 \times 2 \times 2 \times 3$ . What is the factorization of 54?

1.  $\frac{1}{11} + \frac{2}{33} =$

2. The number 42.31 could be written out as 'forty-two and thirty-one hundredths'. Write out the number 123.42 in a similar way.

3. Round the number 0.36 to the nearest tenth.

4. The numbers  $x$  and  $y$  have the following properties:  $x + 1 = 2$ , and  $x + y = 5$ . What are  $x$  and  $y$ ?

5. The divisors of 27 are 1, 3, 9, and 27. What are the divisors of 28? (Hint: there are six of them.)

6. Which number is larger,  $\frac{2}{3}$  or 0.75?

7. The chart below shows how much carbon dioxide ( $\text{CO}_2$ ) was in the atmosphere each month in 2011. Which month had the highest level of  $\text{CO}_2$ ? Can you guess why?

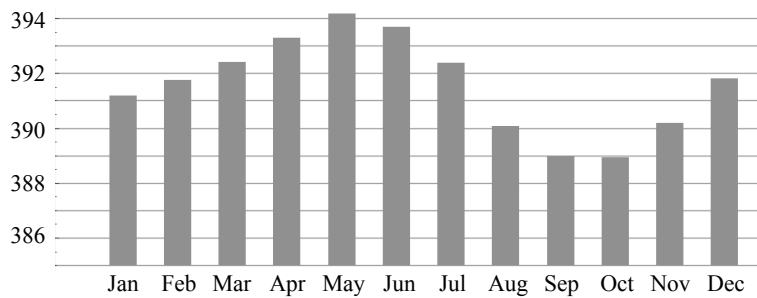

$$\begin{array}{r} 16 \\ \times 3 \\ \hline \end{array}$$

$$\begin{array}{r} 9 \\ \times 6 \\ \hline \end{array}$$

$$\begin{array}{r} 45 \\ \div 9 \\ \hline \end{array}$$

$$\begin{array}{r} 2039 \\ - 1994 \\ \hline \end{array}$$

$$\begin{array}{r} 50 \\ \times 50 \\ \hline \end{array}$$

$$\begin{array}{r} 225 \\ \div 5 \\ \hline \end{array}$$

$$\begin{array}{r} 9 \\ \times 9 \\ \hline \end{array}$$

$$\begin{array}{r} 1.29 \\ + 21.88 \\ \hline \end{array}$$

$$\begin{array}{r} 729 \\ \div 27 \\ \hline \end{array}$$

$$\begin{array}{r} 245 \\ \div 7 \\ \hline \end{array}$$

1. Circle the prime numbers which are factors of 245:

2    3    5    7    11    13    17

2. Round the numbers 58 and 33 to the nearest ten, and multiply the rounded numbers.

3. Mark all of the angles in the picture below which are 60 degrees. The angles in a triangle add up to 180 degrees, and so do the angles on one side of a straight line.

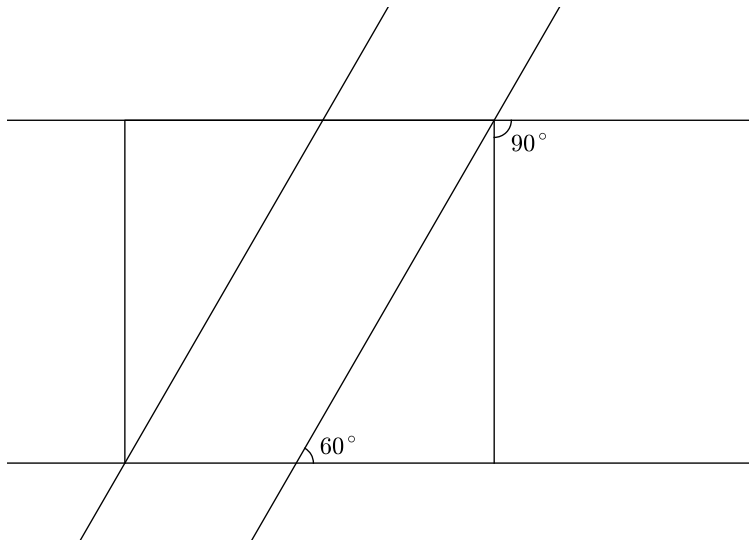

1. Circle the correct equation.

a)  $\frac{4}{10} = \frac{3}{6}$

b)  $\frac{1}{2} = \frac{7}{8}$

c)  $\frac{1}{2} = \frac{3}{6}$

d)  $\frac{4}{10} = \frac{7}{8}$

2. Which pair of expressions are equivalent to each other?

a)  $2 \times 2 \times 2$  and  $3^2$

b)  $6 \times 6 \times 6 \times 6$  and  $4^6$

c)  $4 \times 4 \times 4 \times 4 \times 4$  and  $4^5$

d)  $8 \times 8 \times 8 \times 8 \times 8 \times 8$  and  $8^8$

3. If  $7 + x = 84$ , what is  $x$ ?

4. There are 60 hikers who need to get across a lake in boats. Each boat can hold up to 7 hikers. What is the least number of boats needed to take all the hikers across the lake in one trip?

5. Norman took a 6-hour car trip. During the first 4 hours, he drove 65 miles each hour. During the next 2 hours, Norman drove 40 miles each hour. What is the total number of miles Norman drove during his entire 6-hour car trip?

6. Mary picks 15 flowers from her garden. If 3 out of 5 of these flowers are yellow, how many yellow flowers did Mary pick?

7. A bus has 14 rows with 4 passenger seats in each row. What is the total number of passenger seats on the bus?

8. What is  $7^2 + 9 + 1^3$ ?

$$\begin{array}{r} 16 \\ \times 3 \\ \hline \end{array}$$

$$\begin{array}{r} 8 \\ \times 6 \\ \hline \end{array}$$

$$\begin{array}{r} 48 \\ \div 4 \\ \hline \end{array}$$

$$\begin{array}{r} 4096 \\ - 2048 \\ \hline \end{array}$$

$$\begin{array}{r} 51 \\ \times 49 \\ \hline \end{array}$$

$$\begin{array}{r} 336 \\ \div 6 \\ \hline \end{array}$$

$$\begin{array}{r} 11 \\ \times 11 \\ \hline \end{array}$$

$$\begin{array}{r} 11.29 \\ - 10.08 \\ \hline \end{array}$$

$$\begin{array}{r} 336 \\ \div 8 \\ \hline \end{array}$$

$$\begin{array}{r} 336 \\ \div 7 \\ \hline \end{array}$$

1. Circle the prime numbers which are factors (divisors) of 336:

2    3    5    7    11    13    17

2. Round the numbers 199 and 54 to the nearest ten, and multiple the rounded numbers.

3. The Board of Directors for the company Uranus Systems has 16 people on it. The company's charter (similar to a constitution) says that in order to change the name of the company, at least 75% of the members of the board must vote in favor of the change. How many votes are needed to change the name of Uranus Systems?

4. Suppose you roll two six-sided dice and add up the two numbers. There is only way to get a sum equal to 2 - that happens if you roll two ones. But there are 5 ways to get them to add up to 8 (see the table below). So the chance of getting a sum of 8 is  $\frac{5}{36}$ . What is the chance that the sum of the two dice rolls is *at least* 10?

Dice roll 1

	1	2	3	4	5	6
1	2	3	4	5	6	7
2	3	4	5	6	7	8
3	4	5	6	7	8	9
4	5	6	7	8	9	10
5	6	7	8	9	10	11
6	7	8	9	10	11	12

Dice roll 2

$$\begin{array}{r} 7 \\ \times 7 \\ \hline \end{array}$$

$$\begin{array}{r} 343 \\ \div 7 \\ \hline \end{array}$$

$$\begin{array}{r} 133 \\ \div 7 \\ \hline \end{array}$$

$$\begin{array}{r} 23 \\ - 35 \\ \hline \end{array}$$

$$\begin{array}{r} 41 \\ \times 39 \\ \hline \end{array}$$

1. Circle the prime numbers which are factors (divisors) of 343:

2    3    5    7    11    13    17    19    23

2. The Duluth Grill is 8 miles from our house. A kilometer is 0.62 miles. **About** how many kilometers is the Duluth Grill from us?

(A) 13 kilometers    (B) 25 kilometers    (C) 5 kilometers    (D) 2.5 kilometers

3. You open a bag of M&M's<sup>®</sup> candy and find to your surprise that 95% of the forty candies are red, and the others are green. How many green ones are there?

4. If you eat  $\frac{1}{3}$  of a pumpkin pie, and mom eats  $\frac{1}{6}$  of the pie, and I eat  $\frac{1}{4}$  of it, and Kenya eats  $\frac{1}{12}$  of it, how much is left?

5. A triangle has two congruent sides (its an isosceles triangle). The perimeter of the triangle is 140 feet. Only one side of the triangle is 40 feet long. What is the length of each of the congruent sides?

6. Can you figure out the rule that gives the  $y$  value from the  $x$  value?

x	y
0	-1
1	2
2	5
3	8
20	59
-1	-4

x	2	3	7	8	9	10
3						
4						
5						
6						
8						

1. Alice is five years younger than her sister Carol. Carol is half the age of her cousin, Mathilda. If Mathilda is twenty years old, how old is Alice?
2. A computer that normally costs \$1000 is in a sale in which everything is "20 percent off". How much does the computer cost during the sale?
3. Can you figure out the rule that gives the  $y$  value from the  $x$  value?

x	y
0	2
1	3
2	6
3	11
10	102
20	402

x	2	3	7	8	9	11
4						
5						
6						
7						
13						

1. Zoe likes her age this year because its a prime number. She has two sisters, Maud and Nell. If you add up Maud's age and Nell's age you get twice Zoe's age. Maud is only 6 - she is the youngest sister. Nell is the oldest sister - she's the only teenager, and her age is a power of two. How old is Zoe?
2. You see a book in a bookstore that you really want to buy. It says it costs \$12 dollars, and you have twelve dollars and three quarters, so you happily go to the register to buy it. But as you wait in line, you realize that you forgot about the sales tax! If the sales tax is 6%, do you have enough money to buy the book?
3. If  $B = A \times A + 2$ , find the missing values of  $A$  and  $B$  in the table below.

A	B
0	2
1	
2	6
3	11
5	
	51
9	
10	102



$$\begin{array}{r} 6 \\ \times 8 \\ \hline \end{array}$$

$$\begin{array}{r} 80 \\ \times 60 \\ \hline \end{array}$$

$$\begin{array}{r} 48 \\ \div 4 \\ \hline \end{array}$$

$$\begin{array}{r} 130 \\ - 32 \\ \hline \end{array}$$

$$\begin{array}{r} 31 \\ \times 29 \\ \hline \end{array}$$

$$\begin{array}{r} 144 \\ \div 6 \\ \hline \end{array}$$

$$\begin{array}{r} 12 \\ \times 12 \\ \hline \end{array}$$

$$\begin{array}{r} 19 \\ \times 21 \\ \hline \end{array}$$

$$\begin{array}{r} 9 \\ \times 11 \\ \hline \end{array}$$

$$\begin{array}{r} 399 \\ \div 7 \\ \hline \end{array}$$

1.  $1 + 2^2 + 3^3 =$

2. Round the numbers 95 and 16 to the nearest ten, and multiply the rounded numbers.

3. What is the sum of the interior angles of a triangle?

4.  $\frac{1}{2} + \frac{1}{3} + \frac{1}{4} =$

5. After the following Scratch code executes, what is the value of  $x$ ?



$$\begin{array}{r} 7 \\ \times 8 \\ \hline \end{array}$$

$$\begin{array}{r} 80 \\ \times 7 \\ \hline \end{array}$$

$$\begin{array}{r} 80 \\ \times 70 \\ \hline \end{array}$$

$$\begin{array}{r} 4321 \\ - 432 \\ \hline \end{array}$$

$$\begin{array}{r} 191 \\ \times 9 \\ \hline \end{array}$$

$$\begin{array}{r} 144 \\ \div 8 \\ \hline \end{array}$$

$$\begin{array}{r} 144 \\ \times 5 \\ \hline \end{array}$$

$$\begin{array}{r} 180 \\ \times 4 \\ \hline \end{array}$$

$$\begin{array}{r} 1001 \\ \times 999 \\ \hline \end{array}$$

$$\begin{array}{r} 187 \\ \div 11 \\ \hline \end{array}$$

1.  $3^2 + 4^2 - 5^2 =$

2. Does every triangle have at least one acute angle?

3. Can a triangle have two obtuse angles?

4. If you flip a coin three times, what is your chance of getting two heads and one tail?

5.  $\frac{2}{5} + \frac{1}{6} =$

$$\begin{array}{r} 7 \\ \times 9 \\ \hline \end{array}$$

$$\begin{array}{r} 21 \\ \times 7 \\ \hline \end{array}$$

$$\begin{array}{r} 147 \\ \div 3 \\ \hline \end{array}$$

$$\begin{array}{r} 35 \\ - 70 \\ \hline \end{array}$$

$$\begin{array}{r} 243 \\ \times 9 \\ \hline \end{array}$$

$$\begin{array}{r} 144 \\ \div 6 \\ \hline \end{array}$$

$$\begin{array}{r} 90 \\ \times 8 \\ \hline \end{array}$$

$$\begin{array}{r} 45 \\ \times 16 \\ \hline \end{array}$$

$$\begin{array}{r} 61 \\ \times 59 \\ \hline \end{array}$$

$$\begin{array}{r} 70 \\ \times 8 \\ \hline \end{array}$$

1.  $12^2 + 5^2 - 13^2 =$

2. What is the mean (average) of the numbers 10,  $-1$ , 5, 6, and 100?

3. If you flip a coin four times, what is your chance of getting four heads?

4. The figure below shows a pentagon and one possible triangulation of it. How many different ways are there of triangulating it?

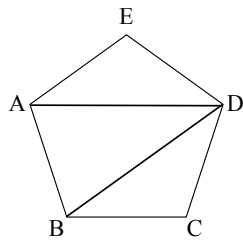
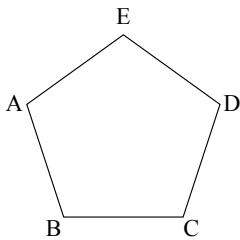

$$\begin{array}{r} 11 \\ \times 11 \\ \hline \end{array}$$

$$\begin{array}{r} 60 \\ \times 6 \\ \hline \end{array}$$

$$\begin{array}{r} 60 \\ \times 60 \\ \hline \end{array}$$

$$\begin{array}{r} 121 \\ + 3600 \\ \hline \end{array}$$

$$\begin{array}{r} 61 \\ \times 61 \\ \hline \end{array}$$

$$\begin{array}{r} 144 \\ \div 3 \\ \hline \end{array}$$

$$\begin{array}{r} 12 \\ \times 8 \\ \hline \end{array}$$

$$\begin{array}{r} 45 \\ \times 3 \\ \hline \end{array}$$

$$\begin{array}{r} 240 \\ \div 15 \\ \hline \end{array}$$

$$\begin{array}{r} 240 \\ \div 8 \\ \hline \end{array}$$

1. If you have a choice between rolling one six-sided die and winning on a 4,5, or 6, OR rolling two dice and winning on a 5 or 6, which one should you choose?

2. Try to figure out the next number in this sequence:

100, 101, 96, 97, 92, 93, 88, 89, \_\_\_\_\_

3. Melissa has a rope that is 84 feet long. She is cutting it into 7-foot pieces to make jump ropes. How many jump ropes can Melissa make?

4. Lisa collects baseball cards. She has 4,381 baseball cards in her collection. She sells 1,427 of her baseball cards. How many baseball cards does Lisa have left?

$$\begin{array}{r} 161 \\ \div 7 \\ \hline \end{array}$$

$$\begin{array}{r} 8 \\ \times 8 \\ \hline \end{array}$$

$$\begin{array}{r} 15 \\ \times 15 \\ \hline \end{array}$$

$$\begin{array}{r} 17 \\ \times 17 \\ \hline \end{array}$$

$$\begin{array}{r} 64 \\ + 225 \\ \hline \end{array}$$

$$\begin{array}{r} 25 \\ \times 7 \\ \hline \end{array}$$

$$\begin{array}{r} 25 \\ \times 8 \\ \hline \end{array}$$

$$\begin{array}{r} 16 \\ \times 16 \\ \hline \end{array}$$

$$\begin{array}{r} 360 \\ \div 45 \\ \hline \end{array}$$

$$\begin{array}{r} 152 \\ \div 8 \\ \hline \end{array}$$

1. The hexagon below is a regular hexagon - each of its sides is the same length, and each angle is the same. How many degrees is the angle ABC?

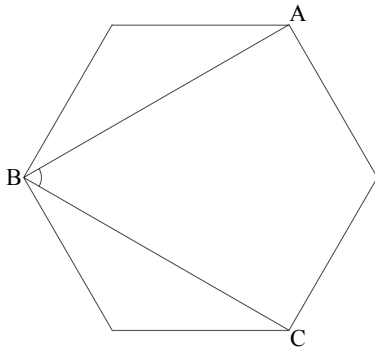

2. Consider the pattern of dots below. The first figure has two dots; how many dots would the tenth figure have?

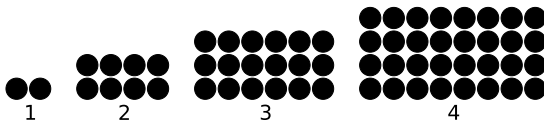

$$\begin{array}{r} 91 \\ \div 7 \\ \hline \end{array}$$

$$\begin{array}{r} 7 \\ \times 7 \\ \hline \end{array}$$

$$\begin{array}{r} 6 \\ \times 13 \\ \hline \end{array}$$

$$\begin{array}{r} 13 \\ \times 8 \\ \hline \end{array}$$

$$\begin{array}{r} 169 \\ - 25 \\ \hline \end{array}$$

$$\begin{array}{r} 250 \\ \times 5 \\ \hline \end{array}$$

$$\begin{array}{r} 125 \\ \div 5 \\ \hline \end{array}$$

$$\begin{array}{r} 1,000 \\ \times 1,000 \\ \hline \end{array}$$

$$\begin{array}{r} 234 \\ \div 13 \\ \hline \end{array}$$

$$\begin{array}{r} 468 \\ \div 13 \\ \hline \end{array}$$

1. Match the fractions with the corresponding pie charts by connecting them with a line. Some of them will not be connected.

$$\frac{3}{4}$$

$$\frac{6}{14}$$

$$\frac{2}{9}$$

$$\frac{1}{5}$$

$$\frac{1}{3}$$

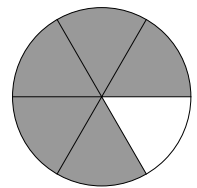
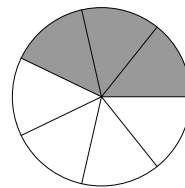
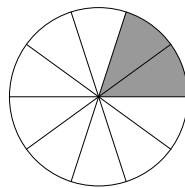
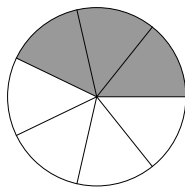
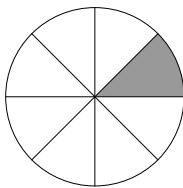

2. Do the "Complete the Cube" problem on pages 84-85 of the Math Puzzles and Games book.

$$\begin{array}{r} 98 \\ \div 7 \\ \hline \end{array}$$

$$\begin{array}{r} 7 \\ \times 7 \\ \hline \end{array}$$

$$\begin{array}{r} 7 \\ \times 14 \\ \hline \end{array}$$

$$\begin{array}{r} 7 \\ \times 8 \\ \hline \end{array}$$

$$\begin{array}{r} 25 \\ - 16 \\ \hline \end{array}$$

$$\begin{array}{r} 2.5 \\ \times 4 \\ \hline \end{array}$$

$$\begin{array}{r} 625 \\ \div 25 \\ \hline \end{array}$$

$$\begin{array}{r} 100 \\ \times 100 \\ \hline \end{array}$$

$$\begin{array}{r} 29 \\ \times 3 \\ \hline \end{array}$$

$$\begin{array}{r} 435 \\ \div 5 \\ \hline \end{array}$$

1. What is  $\frac{1}{2}$  divided by  $\frac{1}{2}$ ?

2. What is the next number in this sequence?

1, 2, 4, 7, 11, 16, 22, \_\_\_\_

3. Do the "Win Big" problem on pages 50 of the Math Puzzles and Games book.

$$\begin{array}{r} 105 \\ \div 7 \\ \hline \end{array}$$

$$\begin{array}{r} 8 \\ \times 8 \\ \hline \end{array}$$

$$\begin{array}{r} 12 \\ \times 8 \\ \hline \end{array}$$

$$\begin{array}{r} 8 \\ \times 6 \\ \hline \end{array}$$

$$\begin{array}{r} 100 \\ - 64 \\ \hline \end{array}$$

$$\begin{array}{r} 0.125 \\ \times 8 \\ \hline \end{array}$$

$$\begin{array}{r} 375 \\ \div 125 \\ \hline \end{array}$$

$$\begin{array}{r} 20 \\ \times 20 \\ \hline \end{array}$$

$$\begin{array}{r} 0.5 \\ \div 0.5 \\ \hline \end{array}$$

$$\begin{array}{r} 128 \\ \div 8 \\ \hline \end{array}$$

1.  $\frac{1}{7} + \frac{1}{5} =$

2. The brothers Grendel and Drchk are quite old. If you add their ages together, you get 2000, but if you subtract Drchk's age from Grendel's, you get 2. How old is Grendel?

3. Which is larger,  $\frac{13}{8}$  or 1.6?

4. The octagon below is a regular octagon - each of its sides is the same length, and each angle is the same. How many degrees is the angle ABC?

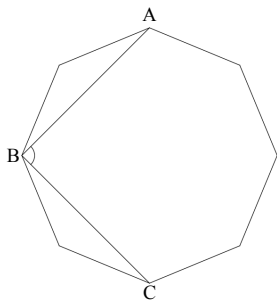



$$\begin{array}{r} 30 \\ \div 5 \\ \hline \end{array}$$

$$\begin{array}{r} 9 \\ \times 9 \\ \hline \end{array}$$

$$\begin{array}{r} 60 \\ \div 12 \\ \hline \end{array}$$

$$\begin{array}{r} 8 \\ \times 3 \\ \hline \end{array}$$

$$\begin{array}{r} 150 \\ - 90 \\ \hline \end{array}$$

$$\begin{array}{r} 2.5 \\ \times 24 \\ \hline \end{array}$$

$$\begin{array}{r} 625 \\ \div 125 \\ \hline \end{array}$$

$$\begin{array}{r} 60 \\ \times 7 \\ \hline \end{array}$$

$$\begin{array}{r} 720 \\ \div 12 \\ \hline \end{array}$$

$$\begin{array}{r} 128 \\ + 384 \\ \hline \end{array}$$

1. What is  $2 \times 2 \times 3 \times 5$ ?

2.  $\frac{1}{4} + \frac{1}{3} + \frac{1}{5} =$

$$\begin{array}{r} 84 \\ \times 8 \\ \hline \end{array}$$

$$\begin{array}{r} 99 \\ \div 9 \\ \hline \end{array}$$

$$\begin{array}{r} 60 \\ \div 5 \\ \hline \end{array}$$

$$\begin{array}{r} 8 \\ \times 5 \\ \hline \end{array}$$

$$\begin{array}{r} 150 \\ - 135 \\ \hline \end{array}$$

$$\begin{array}{r} 2.5 \\ \times 4 \\ \hline \end{array}$$

$$\begin{array}{r} 125 \\ \times 8 \\ \hline \end{array}$$

$$\begin{array}{r} 125 \\ \times 7 \\ \hline \end{array}$$

$$\begin{array}{r} 875 \\ \div 125 \\ \hline \end{array}$$

$$\begin{array}{r} 256 \\ - 96 \\ \hline \end{array}$$

1. Helen is a photographer. She keeps her printed photos in special notebooks, each of which hold 125 photos. If she has 600 photographs, how many notebooks does she need?
2. Which number will make the inequality true?

$$(36 \times 8) \div \underline{\quad} > 72$$

- a) 2
- b) 5
- c) 6
- d) 7

$$\begin{array}{r} 71 \\ \times 7 \\ \hline \end{array}$$

$$\begin{array}{r} 121 \\ \div 11 \\ \hline \end{array}$$

$$\begin{array}{r} 62 \\ \div 31 \\ \hline \end{array}$$

$$\begin{array}{r} 8 \\ \times 7 \\ \hline \end{array}$$

$$\begin{array}{r} 112 \\ - 35 \\ \hline \end{array}$$

$$\begin{array}{r} 0.125 \\ \times 8 \\ \hline \end{array}$$

$$\begin{array}{r} 333 \\ \times 6 \\ \hline \end{array}$$

$$\begin{array}{r} 334 \\ \times 6 \\ \hline \end{array}$$

$$\begin{array}{r} 1125 \\ \div 125 \\ \hline \end{array}$$

$$\begin{array}{r} 2048 \\ - 512 \\ \hline \end{array}$$

1. Which number is ten thousand seven hundred and twenty?

- a) 17,200
- b) 17,020
- c) 10,720
- d) 10,702

2. Can you figure out the rule that gives the  $y$  value from the  $x$  value?

x	y
1	4
3	8
7	16
10	22
20	42
100	202

$$\begin{array}{r} 13 \\ \times 31 \\ \hline \end{array}$$

$$\begin{array}{r} 12221 \\ \div 11 \\ \hline \end{array}$$

$$\begin{array}{r} 126 \\ \div 9 \\ \hline \end{array}$$

$$\begin{array}{r} 9 \\ \times 7 \\ \hline \end{array}$$

$$\begin{array}{r} 1023 \\ - 25 \\ \hline \end{array}$$

$$\begin{array}{r} 0.12 \\ \times 50 \\ \hline \end{array}$$

$$\begin{array}{r} 105 \\ \times 5 \\ \hline \end{array}$$

$$\begin{array}{r} 41 \\ \times 6 \\ \hline \end{array}$$

$$\begin{array}{r} 1250 \\ \div 125 \\ \hline \end{array}$$

$$\begin{array}{r} 5 \\ \times 9 \\ \hline \end{array}$$

1. Circle all the values of  $x$  that make the following inequality true:

$$1.5 + x < 10$$

- a)  $x = 2.8$
- b)  $x = 8.1$
- c)  $x = 9.2$
- d)  $x = 11.5$

2. Draw the line  $y = 2x$  in the box below. The  $x$  value is horizontal, the  $y$  value is vertical. For example, if  $x = 2$ , then  $y = 4$ , and the point  $(2, 4)$  is on the line.

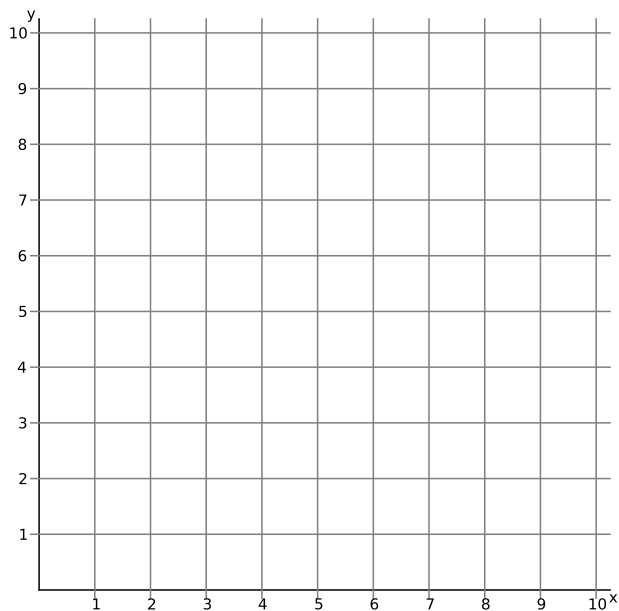

$$\begin{array}{r} 8 \\ \times 8 \\ \hline \end{array}$$

$$\begin{array}{r} 128 \\ \div 8 \\ \hline \end{array}$$

$$\begin{array}{r} 128 \\ \div 2 \\ \hline \end{array}$$

$$\begin{array}{r} 9 \\ \times 7 \\ \hline \end{array}$$

$$\begin{array}{r} 1024 \\ - 64 \\ \hline \end{array}$$

$$\begin{array}{r} 128 \\ \times 0.5 \\ \hline \end{array}$$

$$\begin{array}{r} 16 \\ \times 4 \\ \hline \end{array}$$

$$\begin{array}{r} 6 \\ \times 6 \\ \hline \end{array}$$

$$\begin{array}{r} 3200 \\ \div 64 \\ \hline \end{array}$$

$$\begin{array}{r} 64 \\ \times 11 \\ \hline \end{array}$$

1. What is  $2^6$ ?

2. What is  $2^{10}$  divided by  $2^9$ ? (Hint: you do not have to figure out what  $2^{10}$  and  $2^9$  are to answer the question!)

3. What fraction of each square is shaded?

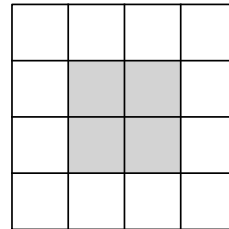
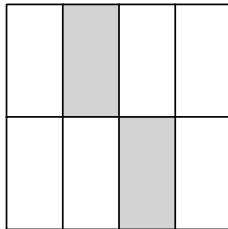
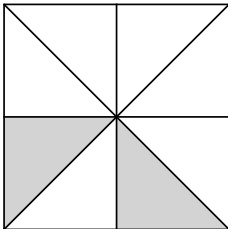

$$\begin{array}{r} 13 \\ \times 5 \\ \hline \end{array}$$

$$\begin{array}{r} 169 \\ \div 13 \\ \hline \end{array}$$

$$\begin{array}{r} 243 \\ \div 3 \\ \hline \end{array}$$

$$\begin{array}{r} 9 \\ \times 6 \\ \hline \end{array}$$

$$\begin{array}{r} 50 \\ - 32 \\ \hline \end{array}$$

$$\begin{array}{r} 128 \\ \times 3 \\ \hline \end{array}$$

$$\begin{array}{r} 57 \\ \div 3 \\ \hline \end{array}$$

$$\begin{array}{r} 3 \\ \times 9 \\ \hline \end{array}$$

$$\begin{array}{r} 1300 \\ \div 26 \\ \hline \end{array}$$

$$\begin{array}{r} 31 \\ \times 31 \\ \hline \end{array}$$

1. What is  $3^3$ ?
2. What is  $3^{10}$  divided by  $3^8$ ?
3. Draw a line through the points  $(0, 1)$ ,  $(1, 2)$ , and  $(2, 3)$ . Can you find an equation for  $y$  in terms of  $x$ ? (This would look like  $y = a \times x + b$  where  $a$  and  $b$  are numbers.)

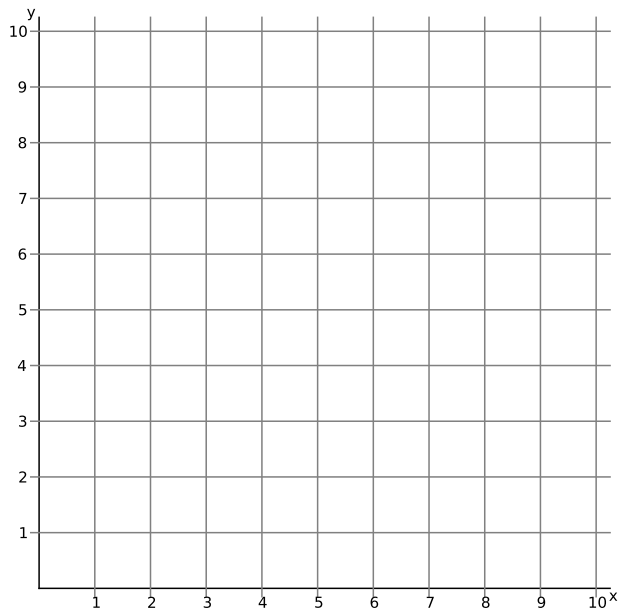

$$\begin{array}{r} 33 \\ \times 5 \\ \hline \end{array}$$

$$\begin{array}{r} 726 \\ \div 66 \\ \hline \end{array}$$

$$\begin{array}{r} 660 \\ \div 3 \\ \hline \end{array}$$

$$\begin{array}{r} 9 \\ \times 4 \\ \hline \end{array}$$

$$\begin{array}{r} 52 \\ - 43 \\ \hline \end{array}$$

$$\begin{array}{r} 32 \\ \times 32 \\ \hline \end{array}$$

$$\begin{array}{r} 72 \\ \div 3 \\ \hline \end{array}$$

$$\begin{array}{r} 4 \\ \times 8 \\ \hline \end{array}$$

$$\begin{array}{r} 500 \\ \div 25 \\ \hline \end{array}$$

$$\begin{array}{r} 30 \\ \times 30 \\ \hline \end{array}$$

1. Considering your answers for  $30 \times 30$  and  $32 \times 32$ , what is a good guess for the square root of one thousand ( $\sqrt{1000}$ )?
2. If your right hand is on the piano you can play five notes on the white keys without any shifting. If you do not play the same note twice in a row, how many ways can you play a short theme of 4 notes?
3. Draw a line through the points  $(0, 7)$ ,  $(1, 6)$ , and  $(3, 4)$ . Can you find an equation for  $y$  in terms of  $x$ ? (This would look like  $y = a \times x + b$  where  $a$  and  $b$  are numbers.)

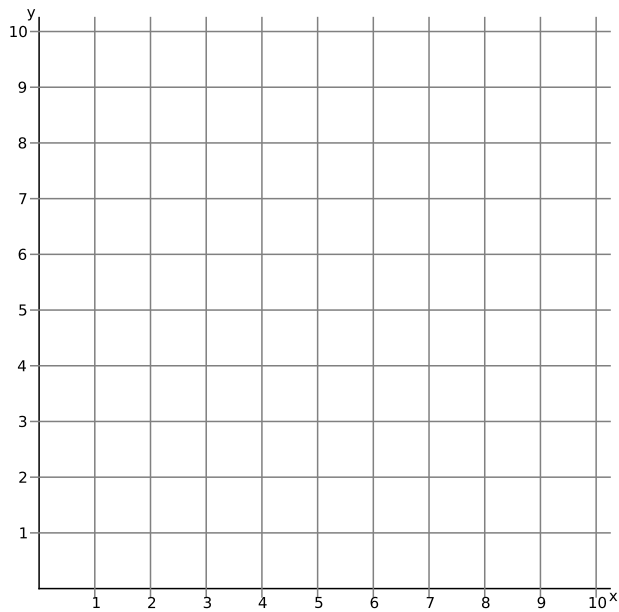

$$\begin{array}{r} 1204 \\ \times 5 \\ \hline \end{array}$$

$$\begin{array}{r} 726 \\ \div 66 \\ \hline \end{array}$$

$$\begin{array}{r} 861 \\ \div 7 \\ \hline \end{array}$$

$$\begin{array}{r} 90 \\ \times 2 \\ \hline \end{array}$$

$$\begin{array}{r} 180 \\ - 135 \\ \hline \end{array}$$

$$\begin{array}{r} 12 \\ \times 12 \\ \hline \end{array}$$

$$\begin{array}{r} 1107 \\ \div 9 \\ \hline \end{array}$$

$$\begin{array}{r} 12 \\ \times 8 \\ \hline \end{array}$$

$$\begin{array}{r} 825 \\ \div 5 \\ \hline \end{array}$$

$$\begin{array}{r} 14 \\ \times 14 \\ \hline \end{array}$$

1. What is  $\sqrt{49}$ ? What is  $\sqrt{100}$ ?  
Use those answers to figure out  $\sqrt{4900}$ .

2. A right angle is 90 degrees. The sum of the three interior angles of a triangle is 180 degrees. There are also 180 degrees in a half-circle. Use these facts to figure out how many degrees angle  $A$  in the picture below has.

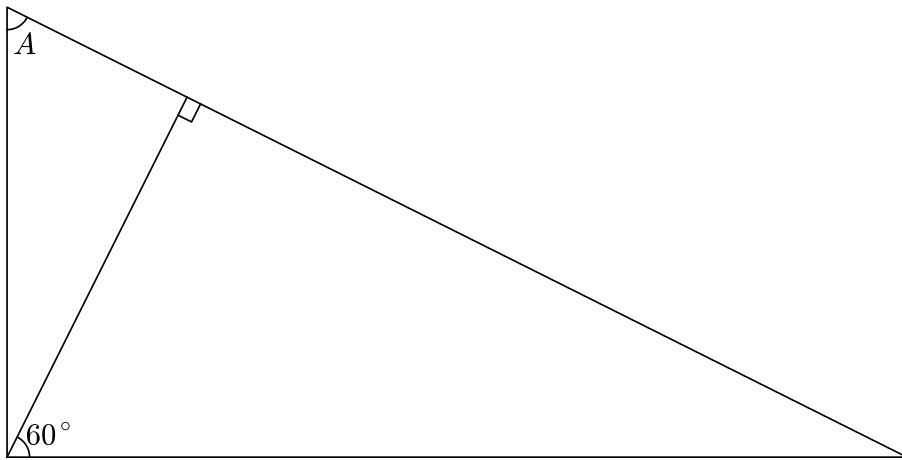



3. Draw a line through the points  $(0, 3)$ ,  $(1, 3)$ , and  $(3, 3)$ . Can you find an equation for  $y$  in terms of  $x$ ? (This would look like  $y = a \times x + b$  where  $a$  and  $b$  are numbers.)

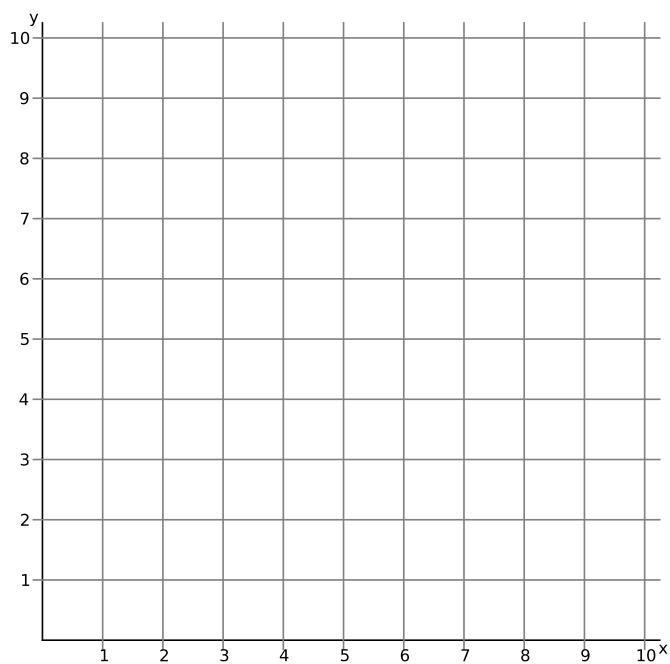

$$\begin{array}{r} 4131 \\ \times 4 \\ \hline \end{array}$$

$$\begin{array}{r} 476 \\ \div 7 \\ \hline \end{array}$$

$$\begin{array}{r} 204 \\ \div 3 \\ \hline \end{array}$$

$$\begin{array}{r} 90 \\ \times 3 \\ \hline \end{array}$$

$$\begin{array}{r} 180 \\ - 45 \\ \hline \end{array}$$

$$\begin{array}{r} 9 \\ \times 12 \\ \hline \end{array}$$

$$\begin{array}{r} 1107 \\ \div 9 \\ \hline \end{array}$$

$$\begin{array}{r} 12 \\ \times 8 \\ \hline \end{array}$$

$$\begin{array}{r} 748 \\ \div 11 \\ \hline \end{array}$$

$$\begin{array}{r} 68 \\ \times 5 \\ \hline \end{array}$$

1. If Bubu Bear is half the weight of Lulu Bear, and Lulu Bear is half the weight of GruGru Bear, and the total of their weights is 1400 pounds, how much does Bubu Bear weigh?
2. The big triangle below is equilateral and equilangular - all of its sides are the same length, and all of its interior angles are 60 degrees.  
This triangle is divided into three smaller triangles. The angles labeled  $A$  are all equal.  
Compute all of the interior angles of the smaller triangles.

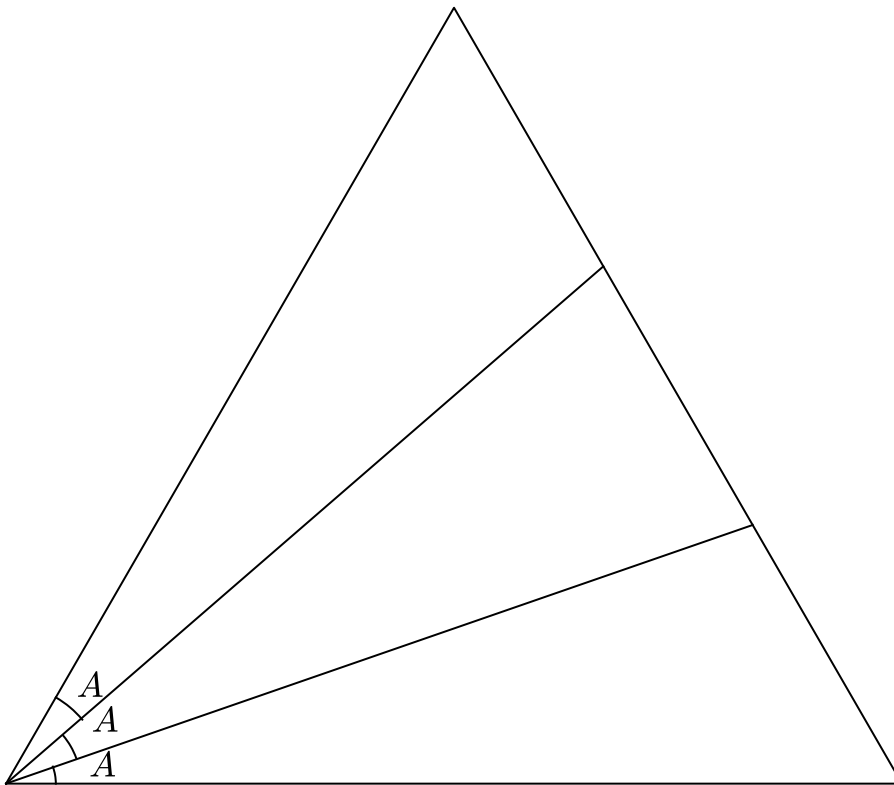

$$\begin{array}{r} 41 \\ \times 3 \\ \hline \end{array}$$

$$\begin{array}{r} 1605 \\ \div 5 \\ \hline \end{array}$$

$$\begin{array}{r} 205 \\ \div 5 \\ \hline \end{array}$$

$$\begin{array}{r} 90 \\ \times 12 \\ \hline \end{array}$$

$$\begin{array}{r} 60 \\ \times 5 \\ \hline \end{array}$$

$$\begin{array}{r} 12 \\ \times 6 \\ \hline \end{array}$$

$$\begin{array}{r} 1926 \\ \div 6 \\ \hline \end{array}$$

$$\begin{array}{r} 12 \\ \times 4 \\ \hline \end{array}$$

$$\begin{array}{r} 1098 \\ - 777 \\ \hline \end{array}$$

$$\begin{array}{r} 69 \\ \times 2 \\ \hline \end{array}$$

1. Is the average (mean) number of arms per person equal to 2, less than 2, or more than 2? (Careful!)
2. Suppose someone offers you the following bet: they will flip a coin, and if its heads, you lose 10 dollars. If its tails, you win 25 dollars. If you are sure the coin is fair, should you take the bet?
3. Which is larger,  $\frac{1}{7}$  or  $\frac{3}{20}$  ?
4. Draw some points  $(A, B)$  for which  $B = A \times A - 10 \times A + 25$ . One such point,  $(6, 1)$ , is already drawn. (Since  $6 \times 6 - 10 \times 6 + 25 = 36 - 60 + 25 = 1$ .)

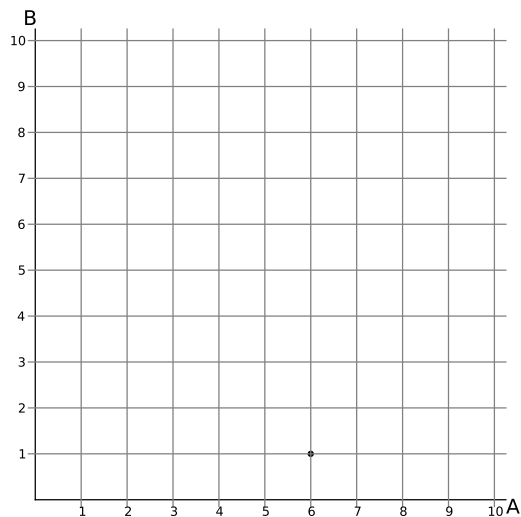

$$\begin{array}{r} 5 \\ \times 6 \\ \hline \end{array}$$

$$\begin{array}{r} 100 \\ \div 5 \\ \hline \end{array}$$

$$\begin{array}{r} 125 \\ \div 5 \\ \hline \end{array}$$

$$\begin{array}{r} 22 \\ \times 22 \\ \hline \end{array}$$

$$\begin{array}{r} 7 \\ \times 6 \\ \hline \end{array}$$

$$\begin{array}{r} 12 \\ \times 7 \\ \hline \end{array}$$

$$\begin{array}{r} 216 \\ \div 6 \\ \hline \end{array}$$

$$\begin{array}{r} 6 \\ \times 6 \\ \hline \end{array}$$

$$\begin{array}{r} 701 \\ - 599 \\ \hline \end{array}$$

$$\begin{array}{r} 70 \\ \times 7 \\ \hline \end{array}$$

1. Which is larger, 0.11 or  $\frac{1}{10}$  ?

2. What is next in the sequence

1, 1, 2, 1, 2, 3, 1, 2, 3, 4, 1, 2, 3, 4, 5, ...

3. The volume of a rectangular box is the width  $\times$  height  $\times$  depth. If you folded up the pattern below into a box, what would its volume be?

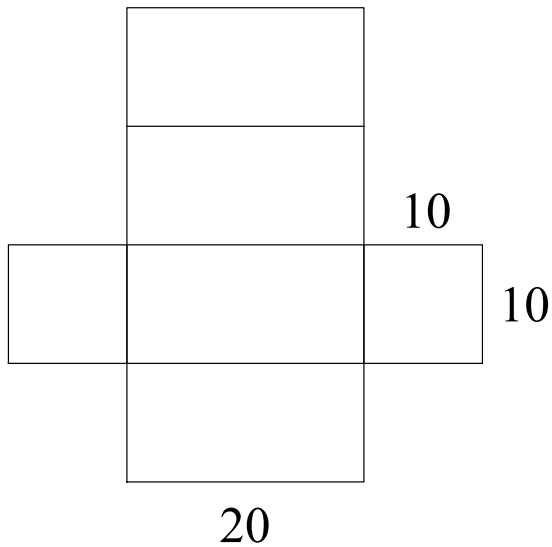

$$\begin{array}{r} 6 \\ \times 3 \\ \hline \end{array}$$

$$\begin{array}{r} 72 \\ \div 4 \\ \hline \end{array}$$

$$\begin{array}{r} 345 \\ \div 5 \\ \hline \end{array}$$

$$\begin{array}{r} 17 \\ \times 17 \\ \hline \end{array}$$

$$\begin{array}{r} 7 \\ \times 8 \\ \hline \end{array}$$

$$\begin{array}{r} 12 \\ \times 6 \\ \hline \end{array}$$

$$\begin{array}{r} 1296 \\ \div 6 \\ \hline \end{array}$$

$$\begin{array}{r} 8 \\ \times 9 \\ \hline \end{array}$$

$$\begin{array}{r} 528 \\ - 456 \\ \hline \end{array}$$

$$\begin{array}{r} 13 \\ \times 7 \\ \hline \end{array}$$

1. How many interior angles of a quadrilateral can be acute?
2. What is  $\frac{1}{3}$  divided by  $\frac{1}{6}$ ?
3. What is the next number in the sequence below?

1, 4, 9, 16, \_\_\_\_

4. To change a temperature in Fahrenheit ( $F$ ) to Celsius ( $C$ ), the formula is

$$C = \frac{9}{5} \times (F - 32)$$

Use the formula to convert  $-3F$  to Celsius.

$$\begin{array}{r} 16 \\ \times 3 \\ \hline \end{array}$$

$$\begin{array}{r} 96 \\ \div 4 \\ \hline \end{array}$$

$$\begin{array}{r} 200 \\ \div 5 \\ \hline \end{array}$$

$$\begin{array}{r} 19 \\ \times 19 \\ \hline \end{array}$$

$$\begin{array}{r} 21 \\ \times 21 \\ \hline \end{array}$$

$$\begin{array}{r} 9 \\ \times 7 \\ \hline \end{array}$$

$$\begin{array}{r} 1029 \\ \div 7 \\ \hline \end{array}$$

$$\begin{array}{r} 18 \\ \times 4 \\ \hline \end{array}$$

$$\begin{array}{r} 288 \\ - 216 \\ \hline \end{array}$$

$$\begin{array}{r} 14 \\ \times 7 \\ \hline \end{array}$$

1. How many interior angles of a quadrilateral can be acute? Some quadrilaterals are shown below (a quadrilateral has four straight sides).

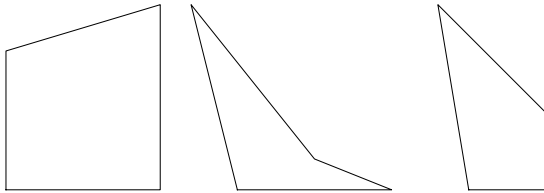

2. What are the next two numbers in the sequence below?

2, 5, 10, 17, \_\_\_\_, \_\_\_\_

3. To change a temperature in Fahrenheit ( $F$ ) to Celsius ( $C$ ), the formula is

$$C = \frac{9}{5} \times (F - 32)$$

For example, if the temperature in Fahrenheit is 37 degrees, then the temperature in Celsius is

$$\frac{9}{5} \times (37 - 32) = \frac{9}{5} \times 5 = 9$$

What is the temperature in Celsius if it is 42 Fahrenheit?

$$\begin{array}{r} 16 \\ \times 5 \\ \hline \end{array}$$

$$\begin{array}{r} 57 \\ \div 3 \\ \hline \end{array}$$

$$\begin{array}{r} 325 \\ \div 5 \\ \hline \end{array}$$

$$\begin{array}{r} 15 \\ \times 15 \\ \hline \end{array}$$

$$\begin{array}{r} 102 \\ \times 51 \\ \hline \end{array}$$

$$\begin{array}{r} 202 \\ \times 7 \\ \hline \end{array}$$

$$\begin{array}{r} 511 \\ \div 7 \\ \hline \end{array}$$

$$\begin{array}{r} 18 \\ \times 3 \\ \hline \end{array}$$

$$\begin{array}{r} 862 \\ - 789 \\ \hline \end{array}$$

$$\begin{array}{r} 73 \\ \times 3 \\ \hline \end{array}$$

1. Write a Scratch program that asks for a temperature in Fahrenheit, and then tells you the corresponding temperature in Celsius. (Remember, first subtract 32 from the Fahrenheit temperature, and then multiply by  $5/9$ .)
2. What are the next two numbers in the sequence below?

1, 9, 25, 49, \_\_\_\_, \_\_\_\_

3. Below is a regular decagon (10 sides of equal length and equal angles between them). Two additional line segments between some vertices have been added. The angle  $A$  is eighteen degrees. How many degrees is angle  $B$ ?

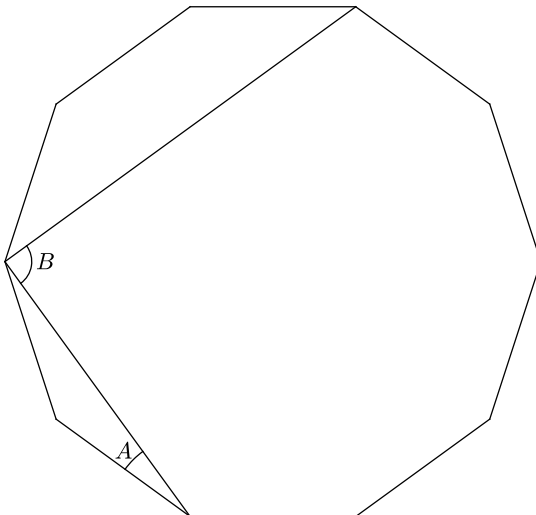

$$\begin{array}{r} 37 \\ \times 2 \\ \hline \end{array}$$

$$\begin{array}{r} 222 \\ \div 3 \\ \hline \end{array}$$

$$\begin{array}{r} 125 \\ \div 5 \\ \hline \end{array}$$

$$\begin{array}{r} 225 \\ \times 4 \\ \hline \end{array}$$

$$\begin{array}{r} 74 \\ \times 5 \\ \hline \end{array}$$

$$\begin{array}{r} 10203 \\ \times 7 \\ \hline \end{array}$$

$$\begin{array}{r} 423 \\ \div 9 \\ \hline \end{array}$$

$$\begin{array}{r} 15 \\ \times 3 \\ \hline \end{array}$$

$$\begin{array}{r} 273 \\ - 199 \\ \hline \end{array}$$

$$\begin{array}{r} 75 \\ \times 3 \\ \hline \end{array}$$

1. Every whole number can be written as a sum of powers of two (i.e. 1, 2, 4, 8, 16, 32, 64, ...) using each power of two at most once. For example,

$$39 = 32 + 4 + 2 + 1$$

Decompose the following numbers in a similar way:

a)  $11 = \underline{\quad} + \underline{\quad} + \underline{\quad}$

b)  $66 = \underline{\quad} + \underline{\quad}$

c)  $28 = \underline{\quad} + \underline{\quad} + \underline{\quad}$

2. What are the next two numbers in the sequence below?

$$1, 5, 17, 37, \underline{\quad}, \underline{\quad}$$



$$\begin{array}{r} 37.5 \\ \times 2 \\ \hline \end{array}$$

$$\begin{array}{r} 225 \\ \div 3 \\ \hline \end{array}$$

$$\begin{array}{r} 375 \\ \div 5 \\ \hline \end{array}$$

$$\begin{array}{r} 75 \\ \times 4 \\ \hline \end{array}$$

$$\begin{array}{r} 75 \\ \div 25 \\ \hline \end{array}$$

$$\begin{array}{r} 12 \\ \times 7 \\ \hline \end{array}$$

$$\begin{array}{r} 57 \\ \div 3 \\ \hline \end{array}$$

$$\begin{array}{r} 9 \\ \times 8 \\ \hline \end{array}$$

$$\begin{array}{r} 1001 \\ - 9 \\ \hline \end{array}$$

$$\begin{array}{r} 15 \\ \times 5 \\ \hline \end{array}$$

1. Every whole number can be written as a sum of powers of two (i.e. 1, 2, 4, 8, 16, 32, 64, ...) using each power of two at most once. For example,

$$39 = 32 + 4 + 2 + 1$$

Decompose the following numbers in a similar way:

a)  $7 =$

b)  $15 =$

c)  $31 =$

2. Draw a five pointed star using the decagon below (the tips of the star should be on vertices of the decagon).

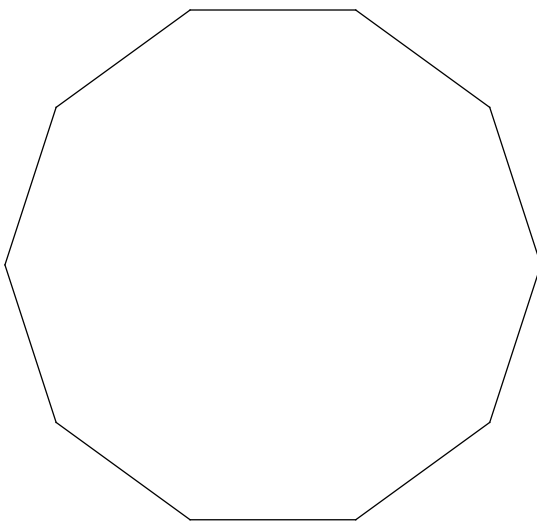

$$\begin{array}{r} 0.125 \\ \times 8 \\ \hline \end{array}$$

$$\begin{array}{r} 246 \\ \div 3 \\ \hline \end{array}$$

$$\begin{array}{r} 875 \\ \div 5 \\ \hline \end{array}$$

$$\begin{array}{r} 75 \\ \times 6 \\ \hline \end{array}$$

$$\begin{array}{r} 250 \\ \div 25 \\ \hline \end{array}$$

$$\begin{array}{r} 12 \\ \times 9 \\ \hline \end{array}$$

$$\begin{array}{r} 570 \\ \div 3 \\ \hline \end{array}$$

$$\begin{array}{r} 9 \\ \times 9 \\ \hline \end{array}$$

$$\begin{array}{r} 1010 \\ - 101 \\ \hline \end{array}$$

$$\begin{array}{r} 32 \\ \times 4 \\ \hline \end{array}$$

1. Every whole number can be written as a sum of powers of two (i.e. 1, 2, 4, 8, 16, 32, 64, ...) using each power of two at most once. For example,

$$39 = 32 + 4 + 2 + 1$$

Because of this property, just as the decimal system uses powers of ten, we can use powers of two to write numbers in *binary*. We can write 39 as:

$$39 = \underline{1} \times 32 + \underline{0} \times 16 + \underline{0} \times 8 + \underline{1} \times 4 + \underline{1} \times 2 + \underline{1} \times 1$$

so in binary, 32 is written as 100111. To make it clear that it is in binary, we can write it as  $100111_2$ . Here is another example: since 8 is a power of two, its binary representation is just  $1000_2$  - it is one eight, zero fours, zero twos, and zero ones.

Convert the following binary numbers to decimals.

a)  $10_2 =$

b)  $100_2 =$

c)  $101_2 =$

$$\begin{array}{r} 101 \\ \times 101 \\ \hline \end{array}$$

$$\begin{array}{r} 8 \\ \times 8 \\ \hline \end{array}$$

$$\begin{array}{r} 15 \\ \times 15 \\ \hline \end{array}$$

$$\begin{array}{r} 64 \\ + 225 \\ \hline \end{array}$$

$$\begin{array}{r} 17 \\ \times 17 \\ \hline \end{array}$$

$$\begin{array}{r} 9 \\ \times 9 \\ \hline \end{array}$$

$$\begin{array}{r} 40 \\ \times 40 \\ \hline \end{array}$$

$$\begin{array}{r} 41 \\ \times 41 \\ \hline \end{array}$$

$$\begin{array}{r} 81 \\ + 1600 \\ \hline \end{array}$$

$$\begin{array}{r} 1573 \\ \div 11 \\ \hline \end{array}$$

1. Vinny 'The Mole' Lagardi has a plan. A plan to rob a bank. But to do it, he needs your help. He promises you 20% of the loot if you can.

Vinny has rented a building near the bank, one with a deep basement. Vinny knows that the wall of the basement is 99 meters west of the bank and 20 meters south. He needs to know exactly how far to tunnel if he digs a straight line towards the bank. He dimly remembers something from school that might help, 'da Pittagory tea-room'? How far should Vinny dig?

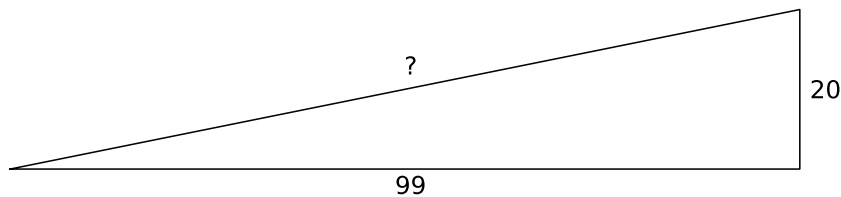

2. Vinny successfully breaks into the vault of the bank and steals 95,381 dollars. He gives you 21,000 dollars. Is Vinny giving you your fair share of 20%?

$$\begin{array}{r} 80 \\ \times 0.5 \\ \hline \end{array}$$

$$\begin{array}{r} 9 \\ \times 8 \\ \hline \end{array}$$

$$\begin{array}{r} 14 \\ \times 13 \\ \hline \end{array}$$

$$\begin{array}{r} 430 \\ - 149 \\ \hline \end{array}$$

$$\begin{array}{r} 18 \\ \times 18 \\ \hline \end{array}$$

$$\begin{array}{r} 6 \\ \times 6 \\ \hline \end{array}$$

$$\begin{array}{r} 88 \\ \times 5 \\ \hline \end{array}$$

$$\begin{array}{r} 44 \\ \times 5 \\ \hline \end{array}$$

$$\begin{array}{r} 22 \\ \times 5 \\ \hline \end{array}$$

$$\begin{array}{r} 187 \\ \div 11 \\ \hline \end{array}$$

1. The area of a right triangle is one-half the base length times the height. For example, the area of the triangle below is

$$\frac{1}{2} \times 5 \times 20 = \frac{1}{2} \times 100 = 50$$

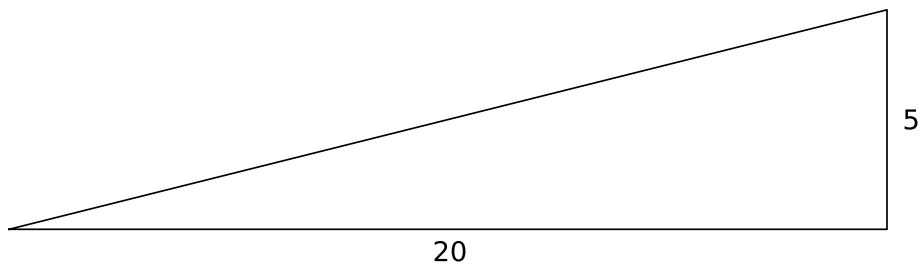

What is the area of this triangle?

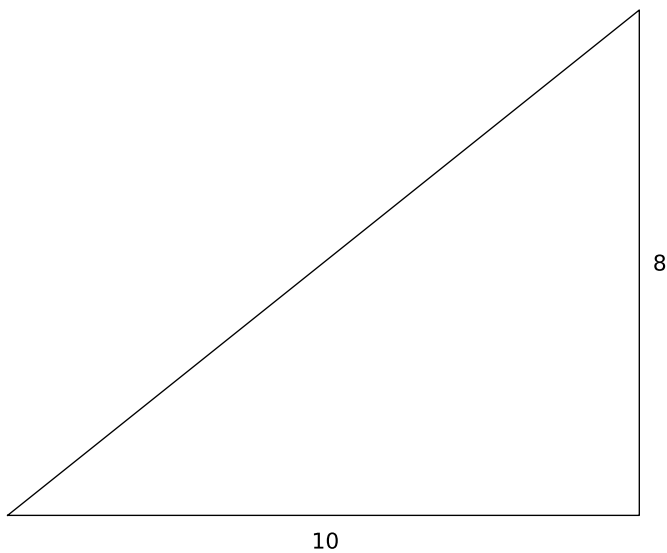

$$\begin{array}{r} 80 \\ \div 8 \\ \hline \end{array}$$

$$\begin{array}{r} 144 \\ \div 12 \\ \hline \end{array}$$

$$\begin{array}{r} 169 \\ \div 13 \\ \hline \end{array}$$

$$\begin{array}{r} 100 \\ - 36 \\ \hline \end{array}$$

$$\begin{array}{r} 16 \\ \times 16 \\ \hline \end{array}$$

$$\begin{array}{r} 36 \\ \div 6 \\ \hline \end{array}$$

$$\begin{array}{r} 88 \\ \div 11 \\ \hline \end{array}$$

$$\begin{array}{r} 625 \\ \div 25 \\ \hline \end{array}$$

$$\begin{array}{r} 102 \\ \div 3 \\ \hline \end{array}$$

$$\begin{array}{r} \text{(careful!)} \quad 0.5 \\ \times 0.5 \\ \hline \end{array}$$

1. The area of a right triangle is one half times the base times the height. Calculate the area of the big triangle below by adding together the areas of the two smaller right triangles inside of it.

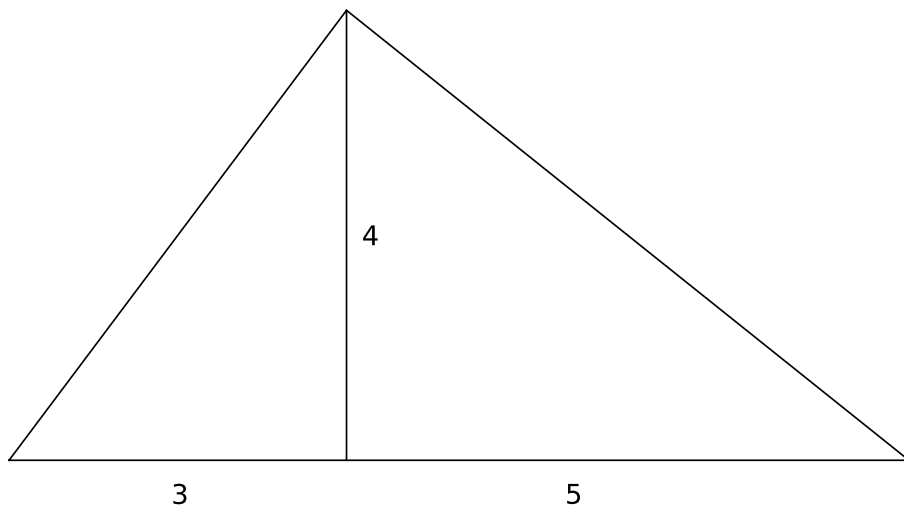

$$\begin{array}{r} 90 \\ \times 90 \\ \hline \end{array}$$

$$\begin{array}{r} 90 \\ \times 15 \\ \hline \end{array}$$

$$\begin{array}{r} 6 \\ \times 15 \\ \hline \end{array}$$

$$\begin{array}{r} 135 \\ - 45 \\ \hline \end{array}$$

$$\begin{array}{r} 720 \\ \div 8 \\ \hline \end{array}$$

$$\begin{array}{r} 4 \\ \times 50 \\ \hline \end{array}$$

$$\begin{array}{r} 360 \\ \div 90 \\ \hline \end{array}$$

$$\begin{array}{r} 810 \\ \div 90 \\ \hline \end{array}$$

$$\begin{array}{r} 81 \\ \div 90 \\ \hline \end{array}$$

$$\begin{array}{r} 45 \\ \times 8 \\ \hline \end{array}$$

1. Suppose you pick a point on a square of origami paper and fold a corner to that point. The folded over region can be a triangle, as shown in the first figure below, or it can be a quadrilateral, as in the second figure. Can you get any other shapes this way for the folded region?

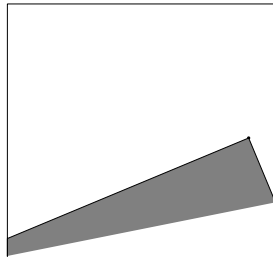
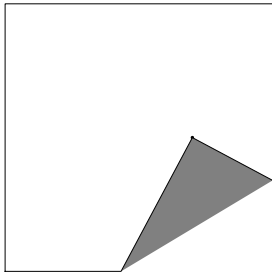

2. (Bonus question - challenging) Try to determine which points would create a triangle after the fold, and which points would create a quadrilateral.

$$\begin{array}{r} 13 \\ \times 7 \\ \hline \end{array}$$

$$\begin{array}{r} 78 \\ + 13 \\ \hline \end{array}$$

$$\begin{array}{r} 12 \\ \times 15 \\ \hline \end{array}$$

$$\begin{array}{r} 455 \\ \div 5 \\ \hline \end{array}$$

$$\begin{array}{r} 617 \\ \times 2 \\ \hline \end{array}$$

1. Velma uses 3 cups of flour and 6 eggs to make 8 huge crepes for her family (Velma likes to make really big crepes). How many cups of flour does she need to make 24 of her huge crepes for a neighborhood picnic?
2. Glenda needs to average 70% on her English tests in order to graduate from Nofun Academy. There are four tests, each 10 points (so she needs to average a 7 out of 10). On her first two tests, Glenda scored 7 points each time. Glenda figures that if she tries hard, she can ace the last test and get 10 points. So she decides not to study much for the third test. What is the lowest score she can get on the third test to still have a chance at averaging 7 points?
3. What is the average (mean) of  $\frac{1}{5}$  and  $\frac{1}{3}$ ?
4. Suppose you cut out the pattern below and folded it to make a cube. What would be the label of the face opposite the X?

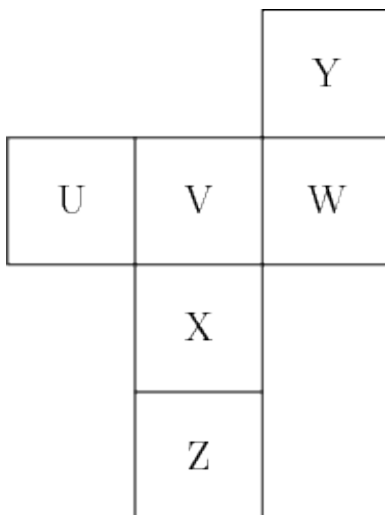

5. How many whole numbers between 10 and 100 contain the digit 2?

$$\begin{array}{r} 8 \\ \times 3 \\ \hline \end{array}$$

$$\begin{array}{r} 8 \\ \times 4 \\ \hline \end{array}$$

$$\begin{array}{r} 12 \\ \times 2 \\ \hline \end{array}$$

$$\begin{array}{r} 5 \\ \times 4 \\ \hline \end{array}$$

$$\begin{array}{r} 32 \\ \div 2 \\ \hline \end{array}$$

1. If the first twelve digits of the decimal representation of  $1/7$  are

0.142857142857

can you guess what the next digit is?

2. Kyle is making 9 birdhouses. He uses 8 nails for each birdhouse. If Kyle has a box of 100 nails, how many nails will he have left after he makes the birdhouses?

3. Complete the quadrilateral to the indicated shape. Try to make the largest one possible.

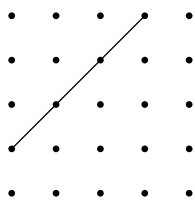

Rectangle

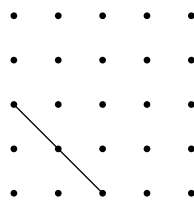

Square

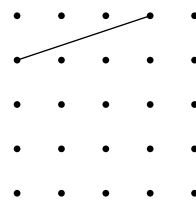

Square

4. What is the length of the line segment AB in the regular hexagon below, if each side of the hexagon is length 1? (Hint: you might want to split the hexagon into triangles.)

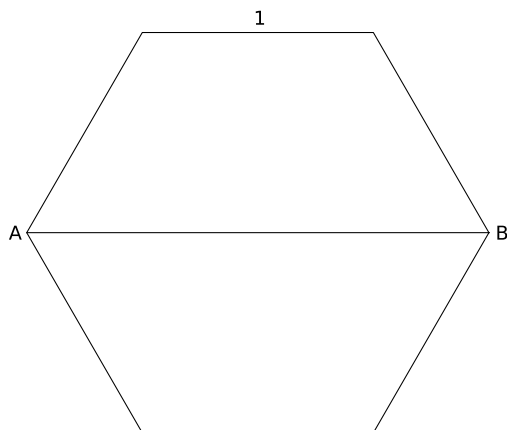



$$\begin{array}{r} 18 \\ \times 3 \\ \hline \end{array}$$

$$\begin{array}{r} 18 \\ \times 4 \\ \hline \end{array}$$

$$\begin{array}{r} 120 \\ \times 30 \\ \hline \end{array}$$

$$\begin{array}{r} 9 \\ \times 50 \\ \hline \end{array}$$

$$\begin{array}{r} 64 \\ \div 4 \\ \hline \end{array}$$

1.  $0.4 + 0.06 + 0.002 =$

2. Label the value of all of the angles in the triangle below.

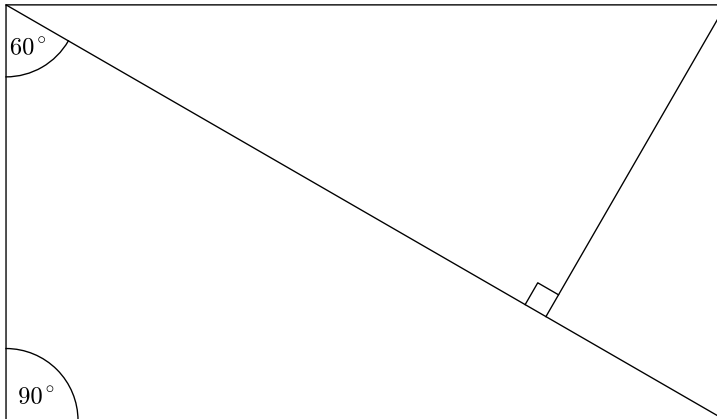

3. Complete the quadrilateral to the indicated shape. Try to make the largest one possible.

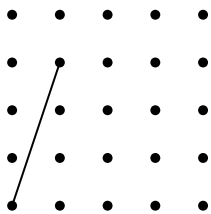

Kite

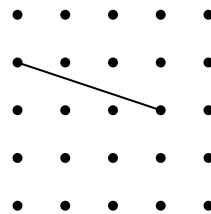

Parallelogram

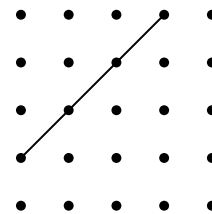

Isosceles  
trapezoid

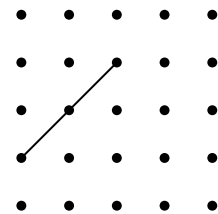

Dart

4. Martians measure angles in clerts. There are 500 clerts in a full circle. How many clerts are there in a right angle?

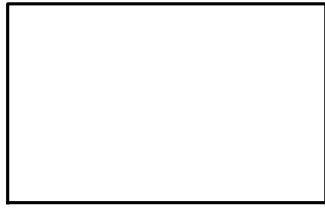

Rectangle  
all angles 90 degrees

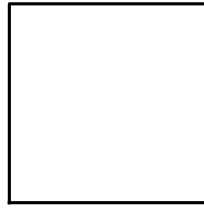

Square  
four equal sides  
all angles 90 degrees

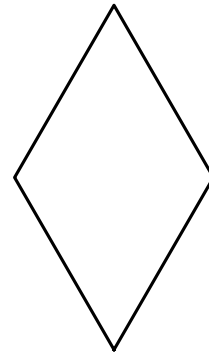

Rhombus  
four equal sides

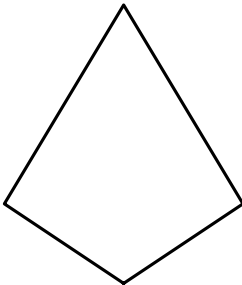

Kite  
two pairs of equal  
adjacent sides, convex

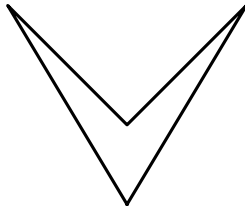

Dart  
concave kite

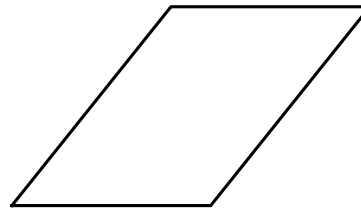

Parallelogram  
two pairs of parallel  
equal sides

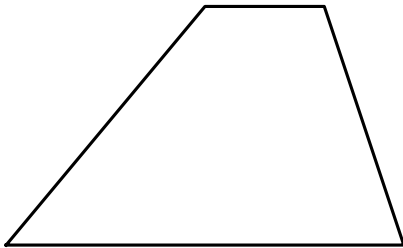

Trapezoid  
one pair of parallel sides

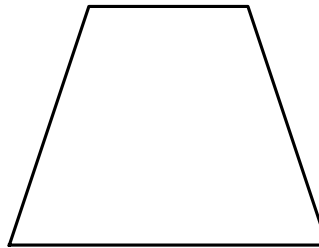

Isosceles trapezoid  
one pair of parallel sides,  
one pair of equal opposite sides

$$\begin{array}{r} 43 \\ \times 8 \\ \hline \end{array}$$

$$\begin{array}{r} 12 \\ \times 5 \\ \hline \end{array}$$

$$\begin{array}{r} 20 \\ \times 5 \\ \hline \end{array}$$

$$\begin{array}{r} 225 \\ \div 5 \\ \hline \end{array}$$

$$\begin{array}{r} 47 \\ \times 2 \\ \hline \end{array}$$

1. Construct a square using a compass and straightedge.

$$\begin{array}{r} 7 \\ \times 6 \\ \hline \end{array}$$

$$\begin{array}{r} 7 \\ \times 9 \\ \hline \end{array}$$

$$\begin{array}{r} 15 \\ \times 20 \\ \hline \end{array}$$

$$\begin{array}{r} 615 \\ \div 5 \\ \hline \end{array}$$

$$\begin{array}{r} 47 \\ \times 2 \\ \hline \end{array}$$

$$\begin{array}{r} 23 \\ \times 7 \\ \hline \end{array}$$

$$\begin{array}{r} 17 \\ \times 3 \\ \hline \end{array}$$

$$\begin{array}{r} 45 \\ \times 6 \\ \hline \end{array}$$

$$\begin{array}{r} 3156 \\ \div 4 \\ \hline \end{array}$$

$$\begin{array}{r} 285 \\ \div 3 \\ \hline \end{array}$$

1. Make an equilateral triangle with origami, starting with a square piece of paper.
2. Try to make the largest equilateral triangle you can in a square using origami.
3. What other regular polygons (equal length sides, equal angles) can you make with origami?
4. Can you make any different ones if you use a compass and straightedge to help?

$$\begin{array}{r} 7 \\ \times 5 \\ \hline \end{array}$$

$$\begin{array}{r} 8 \\ \times 9 \\ \hline \end{array}$$

$$\begin{array}{r} 15 \\ \times 20 \\ \hline \end{array}$$

$$\begin{array}{r} 2280 \\ \div 5 \\ \hline \end{array}$$

$$\begin{array}{r} 144 \\ \times 3 \\ \hline \end{array}$$

$$\begin{array}{r} 203 \\ - 7 \\ \hline \end{array}$$

$$\begin{array}{r} 27 \\ \times 3 \\ \hline \end{array}$$

$$\begin{array}{r} 45 \\ \times 6 \\ \hline \end{array}$$

$$\begin{array}{r} 2048 \\ \div 4 \\ \hline \end{array}$$

$$\begin{array}{r} 285 \\ \div 3 \\ \hline \end{array}$$

1. Try to guess the next two numbers in this sequence:

1, 1, 2, 3, 4, 9, 8, 27, ...

2. What is  $z$  equal to if  $\frac{z}{2} + 1 = 1$ ?

3. What is  $\frac{2}{4} + \frac{1}{6}$ ? Simplify your answer as much as possible.

4. Write a Scratch program called 'Hello Pythagoras'. The program should first show the words, 'Hello Pythagoras', and then ask for two numbers,  $a$  and  $b$ . After the two numbers are entered, it should display  $c = \sqrt{a^2 + b^2}$ .

1. Simplify this fraction as much as possible:  $\frac{13}{143}$

2. There is one prime number in this list - which one is it?

1, 9, 15, 43, 57, 1001

3. If you flip a coin four times, what is the chance that you get one head and one tail (in either order)?

4.  $75 = 3 \times 5^{\square}$  (fill in the missing exponent).

5. Use Dragonbox-like steps to solve for  $z$  if  $\frac{2 \times 7 \times z}{7 \times 5} + 3 = 5$

6. Simplify this fraction as much as possible:  $\frac{72}{144}$

7. Use Ruby to write a 'Hello World' function: On your computer, open a Terminal application. At the prompt, type

```
irb
```

Then enter

```
def Hello()  
  puts "Hello World"  
end
```

then execute the function:

```
Hello()
```

1. Fill in the next line of Pascal's triangle.

```
      1
     1 1
    1 2 1
   1 3 3 1
```

2. If you flip a coin four times, the chance that you will get a particular number of heads is shown below. What is the chance of getting 2 or more heads?

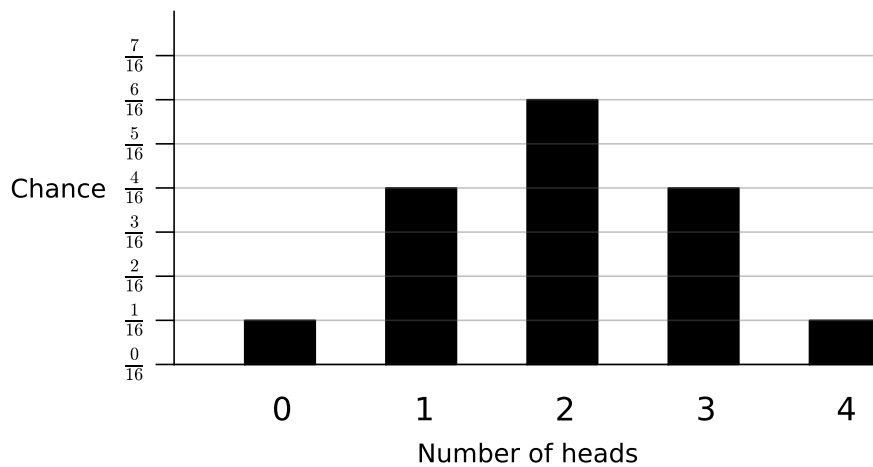

3. How do the probabilities above relate to Pascal's triangle?

4. Simplify this fraction as much as possible:  $\frac{5}{280}$

5. Write a 'Hello Pythagoras' function in Ruby. The program should first show the words, 'Hello Pythagoras', and then ask for two numbers, a and b. After the two numbers are entered, it should display  $c = \sqrt{a^2 + b^2}$ .

You can write it using an editor such as TextWrangler on a Mac, or notepad++ on a Windows machine. You will probably want to use the `puts`, `gets.chomp` and `Math.sqrt` commands. To tell the shell (bash) to execute your program with Ruby, The first line should be

```
#!/usr/bin/ruby
```

$$\begin{array}{r} 45 \\ \times 54 \\ \hline \end{array}$$

$$\begin{array}{r} 33 \\ \times 3 \\ \hline \end{array}$$

$$\begin{array}{r} 201 \\ \times 102 \\ \hline \end{array}$$

$$\begin{array}{r} 396 \\ \div 4 \\ \hline \end{array}$$

$$\begin{array}{r} 99 \\ \times 3 \\ \hline \end{array}$$

1. Simplify this fraction as much as possible:  $\frac{22}{88}$

2. There is one prime number in this list - which one is it?

8, 25, 36, 71, 91, 99

3. What is  $Z$  if  $\frac{2 \times Z}{3} = 1 + \frac{1}{3}$ ?

4. In Squeak, have at least one Workspace and one Transcript window open. In the Workspace window, put

```
Transcript show: 'Hello World'
```

If you execute this by pressing ⌘-D (or by right-clicking and choosing 'do it (d)'), then 'Hello World' should appear in the Transcript window.



$$\begin{array}{r} 36 \\ + 64 \\ \hline \end{array}$$

$$\begin{array}{r} 400 \\ \times 0.25 \\ \hline \end{array}$$

$$\begin{array}{r} 201 \\ - 102 \\ \hline \end{array}$$

$$\begin{array}{r} 169 \\ \div 13 \\ \hline \end{array}$$

$$\begin{array}{r} 97 \\ \times 3 \\ \hline \end{array}$$

1. What is  $((1 + 2 + 3) \times 4) \times 4 + 4$ ?
2. Using any two of the numbers  $\frac{1}{5}, 1, 5, 10, 50, 100$ , what is the smallest number you can make using subtraction? Keep in mind that the result does not have to be positive.
3. Using any two of the numbers  $\frac{1}{5}, 1, 5, 10, 50, 100$ , what is the smallest number you can make using division? Keep in mind that the result does not have to be a whole number.

1. You are working for the Cheezio<sup>®</sup> Corporation, makers of fine poofy cheezio snacks. There are three elementary schools in Sucker County that are sadly far from any Cheezio<sup>®</sup> factory so you decide to build a factory in Sucker County.

Pick a factory location, as accurately as you can, that would be equally distant from each school. Is it possible to find an exact solution to this?

Puddingtoes Elementary



Runnynose Elementary



Greenhair Elementary

2. You play a fantastically fun new game called 'Bees'. Part of the game is that you distribute 21 points among six bins. Bob decides to allocate his points as  $(0, 0, 0, 7, 7, 7)$ . You choose the distribution  $(1, 1, 1, 2, 8, 8)$ . If a random number is picked from each list, who is more likely to win, you or Bob?
3. How many times can you fold a piece of origami paper in half?
4. If you had a huge piece of paper and you could fold it in half many times, how many folds would it take until it was thicker than the whole planet Earth? (Guess.)
5. Watch the video '<http://ed.ted.com/lessons/steve-kelly-logarithms-explained>' (you could Google the words 'ted ed logarithm kelly' and it should come up). Then answer this question: which is larger,  $\log_2 7$  or  $\log_3 7$ ?

1. Claire Haskell, private detective, knows that she will be staking out an apartment for what could be hours. She decides to go to Dubious Doug's House of Hot Dogs, which is near the apartment, and buy as many hot dogs as she can. All she has is \$6.03, but Doug's hot dogs are really cheap - 71 cents each. How many hot dogs can she buy, and how much money will she have left?
2. Find a point that is equally distant from each vertex of the triangle as best you can.

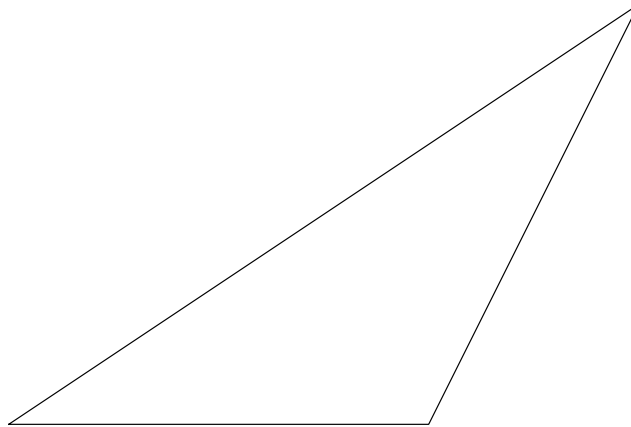

3. Recall that the equation  $\log_b(n) = p$  is the same as saying  $b^p = n$ . For example,  $\log_2(8) = 3$  (since  $2^3 = 2 \times 2 \times 2 = 8$ , and  $\log_{10}(10,000) = 4$  (since  $10^4 = 10 \times 10 \times 10 \times 10 = 10,000$ ). Find the following logarithms:
  - a)  $\log_2 16 =$
  - b)  $\log_4 16 =$
  - c)  $\log_3 27 =$
  - d)  $\log_2 1024 =$
4. Zelda the squirrel eats 5 acorns, on average, every day. Charles eats three times as much as Zelda, and Horatio eats 5 acorns a day less than Charles. How many acorns a day does Horatio eat?

1. Given a rectangle box of width  $a$ , height  $b$ , and depth  $c$ , the distance  $d$  between opposite corners satisfies the equation  $d^2 = a^2 + b^2 + c^2$ . What is the distance  $d$  for a box that is 2 feet wide, 1 feet high, and 2 feet deep?
2. Foxy five: use each of the numbers exactly once in an arithmetical combination (using addition, subtraction, multiplication, and/or division) to make the given number:  
Example: make 16 from 7, 8, 1, 9, and 9. One possible answer:  $(9 \div 9) \times (7 + 8 + 1) = 16$ .
  - a) Make 5 from 1, 5, 3, 6, and 10.
  - b) Make 2 from 8, 11, 9, 1, and 8.
3. What is a number between  $\frac{1}{6}$  and  $\frac{1}{3}$ ?
4. Veronica, Velma, and Vicky go for a walk in Vancouver. Initially, Vicky has three times as much cash as Veronica, while Velma has twice as much cash as Veronica. All their money combined is 24 dollars. After they each buy an ice cream cone for three dollars per cone, Vicky has nine times as much cash as Veronica, while Velma has four dollars more than Veronica and four dollars less than Vicky.  
How much cash did they each have to start with?
5. What is  $2^{10} - 10^3$  equal to?