

HCD-MX500i/MX550i

SERVICE MANUAL

Ver. 1.0 2010.05



Photo: HCD-MX550i

Canadian Model
Chinese Model
Singapore Model
HCD-MX500i
AEP Model
HCD-MX500i/MX550i
UK Model
HCD-MX550i

- HCD-MX500i is the amplifier, CD player, tuner, USB (Except Canadian) and iPod/iPhone section in CMT-MX500i.
- HCD-MX550i is the amplifier, CD player, tuner, USB and iPod/iPhone section in CMT-MX550i.

- iPod is a trademark of Apple Inc.
- iPhone is a trademark of Apple Inc.
- MPEG Layer-3 audio coding technology and patents licensed from Fraunhofer IIS and Thomson.
- Windows Media is either a registered trademark or trademark of Microsoft Corporation in the United States and/or other countries.
- This product is protected by certain intellectual property rights of Microsoft Corporation. Use or distribution of such technology outside of this product is prohibited without a license from Microsoft or an authorized Microsoft subsidiary.
- All other trademarks and registered trademarks are of their respective holders. In this manual, ™ and ® marks are not specified.

Model Name Using Similar Mechanism	NEW
CD Mechanism Type	CDM85CD-DVBU102
Optical Pick-up Block Name	KHM-313CAA

SPECIFICATIONS

Main unit

AUDIO POWER SPECIFICATIONS

With 6 ohm loads, both channels driven, from 120 — 10,000 Hz; rated 30 watts per channel minimum RMS power, with no more than 10% total harmonic distortion from 250 milliwatts to rated output.

Amplifier section

European model:

DIN power output (rated): 25 watts + 25 watts (6 ohms at 1 kHz, DIN)
Continuous RMS power output (reference): 30 watts + 30 watts (6 ohms at 1 kHz, 10% THD)
Music power output (reference): 30 watts + 30 watts (6 ohms at 1 kHz, 10% THD)

Other models:

DIN power output (rated): 25 watts + 25 watts (6 ohms at 1 kHz, DIN)
Continuous RMS power output (reference): 30 watts + 30 watts (6 ohms at 1 kHz, 10% THD)

Input

AUDIO IN (stereo mini jack): Sensitivity 700 mV, impedance 47 kilohms

Outputs

SPEAKERS: Accepts impedance of 6 ohms

CD player section

System: Compact disc and digital audio system

Laser Diode Properties

Emission Duration: Continuous

Laser Output*: Less than 44.6µW

* This output is the value measurement at a distance of 200mm from the objective lens surface on the Optical Pick-up Block with 7mm aperture.

Frequency response: 20 Hz — 20 kHz

Signal-to-noise ratio: More than 90 dB

Dynamic range: More than 90 dB

Tuner section

FM tuner section:

FM stereo, FM superheterodyne tuner

Tuning range:

North American model: 87.5 MHz — 108.0 MHz (100 kHz step)

Other models: 87.5 MHz — 108.0 MHz (50 kHz step)

Antenna: FM lead antenna

Antenna terminals: 75 ohms unbalanced

Intermediate frequency: 10.7 MHz

DAB/DAB+ tuner section (MX550i only):

FM stereo, DAB/FM superheterodyne tuner

Frequency range*

Band-III: 174.928 (5A) MHz — 239.200 (13F) MHz

* For details, see "DAB/DAB+ frequency table" below.

Antenna: DAB/FM lead antenna

Antenna terminal: 75 ohms, F female

DAB/DAB+ frequency table (Band-III)

Frequency	Label	Frequency	Label
174.928 MHz	5A	209.936 MHz	10A
176.640 MHz	5B	211.648 MHz	10B
178.352 MHz	5C	213.360 MHz	10C
180.064 MHz	5D	215.072 MHz	10D
181.936 MHz	6A	216.928 MHz	11A
183.648 MHz	6B	218.640 MHz	11B
185.360 MHz	6C	220.352 MHz	11C
187.072 MHz	6D	222.064 MHz	11D
188.928 MHz	7A	223.936 MHz	12A
190.640 MHz	7B	225.648 MHz	12B
192.352 MHz	7C	227.360 MHz	12C
194.064 MHz	7D	229.072 MHz	12D
195.936 MHz	8A	230.784 MHz	13A
197.648 MHz	8B	232.496 MHz	13B
199.360 MHz	8C	234.208 MHz	13C
201.072 MHz	8D	235.920 MHz	13D
202.928 MHz	9A	237.488 MHz	13E
204.640 MHz	9B	239.200 MHz	13F
206.352 MHz	9C		
208.064 MHz	9D		

* Frequencies are displayed to two decimal places on this system.

iPod/iPhone section

Compatible iPod/iPhone models:

- iPod touch 2nd generation
- iPod touch 1st generation
- iPod classic 120 GB, 160 GB (2009)
- iPod classic 160 GB (2007)
- iPod classic 80 GB
- iPod nano 5th generation (video camera)
- iPod nano 4th generation (video)
- iPod nano 3rd generation (video)
- iPod nano 2nd generation (aluminum)
- iPod nano 1st generation
- iPod 5th generation (video)
- iPod 4th generation (color display)
- iPod 4th generation
- iPod mini
- iPhone
- iPhone 3G
- iPhone 3GS

USB section (except for North American model)

Supported bit rate:

- MP3 (MPEG 1 Audio Layer-3): 32 kbps — 320 kbps, VBR
- WMA: 48 kbps — 192 kbps, VBR
- AAC: 48 kbps — 320 kbps

Sampling frequencies:

- MP3 (MPEG 1 Audio Layer-3): 32/44.1/48 kHz
- WMA: 44.1 kHz
- AAC: 44.1 kHz

⚡ (USB) port: Type A, maximum current 500 mA

General

Power requirements:

- North American model: AC 120 V, 60 Hz
- Other models: AC 220 V — 240 V, 50/60 Hz

Power consumption: 33 watts

Dimensions (W/H/D) (excl. speakers):

Approx. 309 mm × 122 mm × 247 mm

Mass (excl. speakers): Approx. 2.9 kg

Design and specifications are subject to change without notice.

- Standby power consumption: 0.5 W
- Halogenated flame retardants are not used in the certain printed wiring boards.

9-889-872-01

2010E05-1

© 2010.05

Sony Corporation

Audio&Video Business Group

Published by Sony Techno Create Corporation

COMPACT DISC RECEIVER

SONY®

NOTES ON CHIP COMPONENT REPLACEMENT

- Never reuse a disconnected chip component.
- Notice that the minus side of a tantalum capacitor may be damaged by heat.

FLEXIBLE CIRCUIT BOARD REPAIRING

- Keep the temperature of soldering iron around 270 °C during repairing.
- Do not touch the soldering iron on the same conductor of the circuit board (within 3 times).
- Be careful not to apply force on the conductor when soldering or unsoldering.

Laser component in this product is capable of emitting radiation exceeding the limit for Class 1.

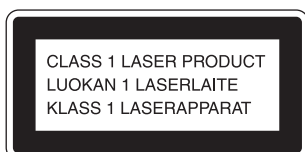

This appliance is classified as a CLASS 1 LASER product. This marking is located on the rear or bottom exterior.

SAFETY-RELATED COMPONENT WARNING!

COMPONENTS IDENTIFIED BY MARK \triangle OR DOTTED LINE WITH MARK \triangle ON THE SCHEMATIC DIAGRAMS AND IN THE PARTS LIST ARE CRITICAL TO SAFE OPERATION. REPLACE THESE COMPONENTS WITH SONY PARTS WHOSE PART NUMBERS APPEAR AS SHOWN IN THIS MANUAL OR IN SUPPLEMENTS PUBLISHED BY SONY.

ATTENTION AU COMPOSANT AYANT RAPPORT À LA SÉCURITÉ!

LES COMPOSANTS IDENTIFIÉS PAR UNE MARQUE \triangle SUR LES DIAGRAMMES SCHÉMATIQUES ET LA LISTE DES PIÈCES SONT CRITIQUES POUR LA SÉCURITÉ DE FONCTIONNEMENT. NE REMPLACER CES COMPOSANTS QUE PAR DES PIÈCES SONY DONT LES NUMÉROS SONT DONNÉS DANS CE MANUEL OU DANS LES SUPPLÉMENTS PUBLIÉS PAR SONY.

关于安全相关零部件的警告

原理图和零件清单中标有 \triangle 记号的零部件，或带有 \triangle 记号的虚线所表示的零部件，对于安全操作至关重要。更换时，必须依据本手册或索尼公司追加发行的手册中列明的零件号，使用索尼公司的零件进行。

TABLE OF CONTENTS

1. SERVICING NOTES	3
2. DISASSEMBLY	
2-1. Disassembly Flow	8
2-2. Case	8
2-3. Front Panel Block	9
2-4. Knob (VOL).....	10
2-5. MAIN Board	10
2-6. SP Board	11
2-7. POWER Board.....	11
2-8. CD Block	12
2-9. BD96/BD96U Board.....	13
2-10. Belt.....	13
2-11. FFC Holder	14
2-11. Optical Pick-up Block (KHM-313CAA).....	14
3. TEST MODE	15
4. ELECTRICAL CHECK	18
5. DIAGRAMS	
5-1. Block Diagram - CD, USB Section -	19
5-2. Block Diagram	
- TUNER, iPod/iPhone, AUDIO IN Section -	20
5-3. Block Diagram - OUTPUT, PANEL Section -	21
5-4. Block Diagram - POWER SUPPLY Section -	22
5-5. Printed Wiring Board	
- BD96/BD96U Board (Side A) -	24
5-6. Printed Wiring Board	
- BD96/BD96U Board (Side B) -	25
5-7. Schematic Diagram - BD96/BD96U Board (1/2) -	26
5-8. Schematic Diagram - BD96/BD96U Board (2/2) -	27
5-9. Printed Wiring Board - DAB Board (MX550i) -	28
5-10. Schematic Diagram - DAB Board (MX550i) -	29
5-11. Printed Wiring Board - MAIN Board (1/2) -	30
5-12. Printed Wiring Boards - MAIN Board (2/2) -	31
5-13. Schematic Diagram - MAIN Section (1/4) -	32
5-14. Schematic Diagram - MAIN Section (2/4) -	33
5-15. Schematic Diagram - MAIN Section (3/4) -	34
5-16. Schematic Diagram - MAIN Section (4/4) -	35
5-17. Printed Wiring Boards - IP/JACK/SP/USB Boards -	36
5-18. Schematic Diagram - IP/JACK/SP/USB Boards -	37
5-19. Printed Wiring Boards - PANEL Section -	38
5-20. Schematic Diagram - PANEL Section -	39
5-21. Printed Wiring Board - POWER Board -	40
5-22. Schematic Diagram - POWER Board -	41
6. EXPLODED VIEWS	
6-1. Case Section.....	54
6-2. Front Panel Section.....	55
6-3. iPod Dock Section	56
6-4. MAIN Board Section	57
6-5. Chassis Section	58
6-6. CD Mechanism Deck Section	
(CDM85CD-DVB102)	59
7. ELECTRICAL PARTS LIST	60

SECTION 1 SERVICING NOTES

NOTES ON HANDLING THE OPTICAL PICK-UP BLOCK OR BASE UNIT

The laser diode in the optical pick-up block may suffer electrostatic break-down because of the potential difference generated by the charged electrostatic load, etc. on clothing and the human body. During repair, pay attention to electrostatic break-down and also use the procedure in the printed matter which is included in the repair parts.

The flexible board is easily damaged and should be handled with care.

NOTES ON LASER DIODE EMISSION CHECK

The laser beam on this model is concentrated so as to be focused on the disc reflective surface by the objective lens in the optical pickup block. Therefore, when checking the laser diode emission, observe from more than 30 cm away from the objective lens.

UNLEADED SOLDER

Boards requiring use of unleaded solder are printed with the lead-free mark (LF) indicating the solder contains no lead.

(Caution: Some printed circuit boards may not come printed with the lead free mark due to their particular size)

: LEAD FREE MARK

Unleaded solder has the following characteristics.

- Unleaded solder melts at a temperature about 40 °C higher than ordinary solder.
Ordinary soldering irons can be used but the iron tip has to be applied to the solder joint for a slightly longer time.
Soldering irons using a temperature regulator should be set to about 350 °C.
Caution: The printed pattern (copper foil) may peel away if the heated tip is applied for too long, so be careful!
- Strong viscosity
Unleaded solder is more viscous (sticky, less prone to flow) than ordinary solder so use caution not to let solder bridges occur such as on IC pins, etc.
- Usable with ordinary solder
It is best to use only unleaded solder but unleaded solder may also be added to ordinary solder.

RELEASING THE ANTITHEFT LOCK

The disc tray lock function for the antitheft of an demonstration disc in the store is equipped.

Releasing Procedure:

1. Press the [I/⏻] button to turn the power on.
2. While pressing the [■] button, press the [▲] button unit "UNLOCKED" displayed on the fluorescent indicator tube (around 5 seconds) .

Note: When "LOCKED" is displayed, the disc tray lock is not released by turning power on/off with the [I/⏻] button.

NOTE OF REPLACING THE MS-203 BOARD

When the MS-203 board is damaged, exchange the entire CDM85 (CD) ASSY.

MODEL IDENTIFICATION

– Back Panel –

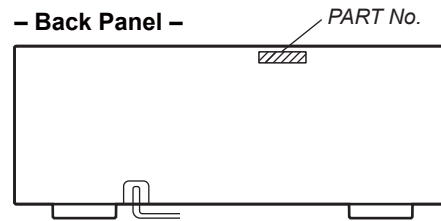

Model	Part No.
HCD-MX500i: AEP model	4-175-955-0□
HCD-MX500i: Canadian model	4-175-955-2□
HCD-MX500i: Singapore model	4-175-955-3□
HCD-MX500i: Chinese model	4-175-955-4□
HCD-MX550i: AEP, UK models	4-175-955-5□

HCD-MX500i/MX550i

CAPACITOR ELECTRICAL DISCHARGE PROCESSING

When checking the board, the electrical discharge is necessary for the electric shock prevention. Connect the resistors referring to the figure below.

- **POWER board (C11, C12) (Canadian model)**
Both ends of respective capacitors.

– POWER Board (Conductor Side) –

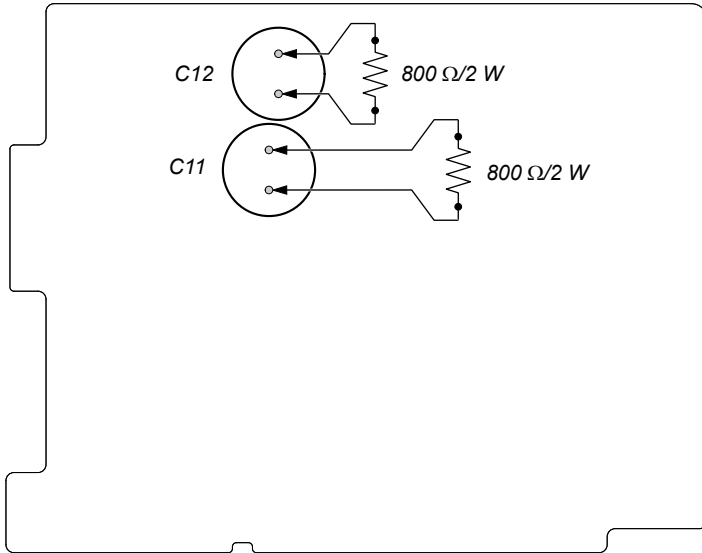

- **POWER board (C10) (Except Canadian model)**
Both ends of respective capacitors.

– POWER Board (Conductor Side) –

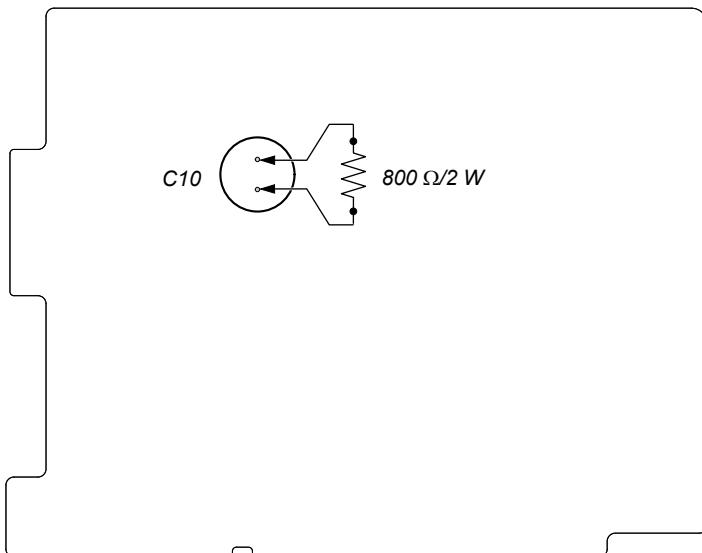

HOW TO OPEN THE TRAY WHEN POWER SWITCH TURN OFF

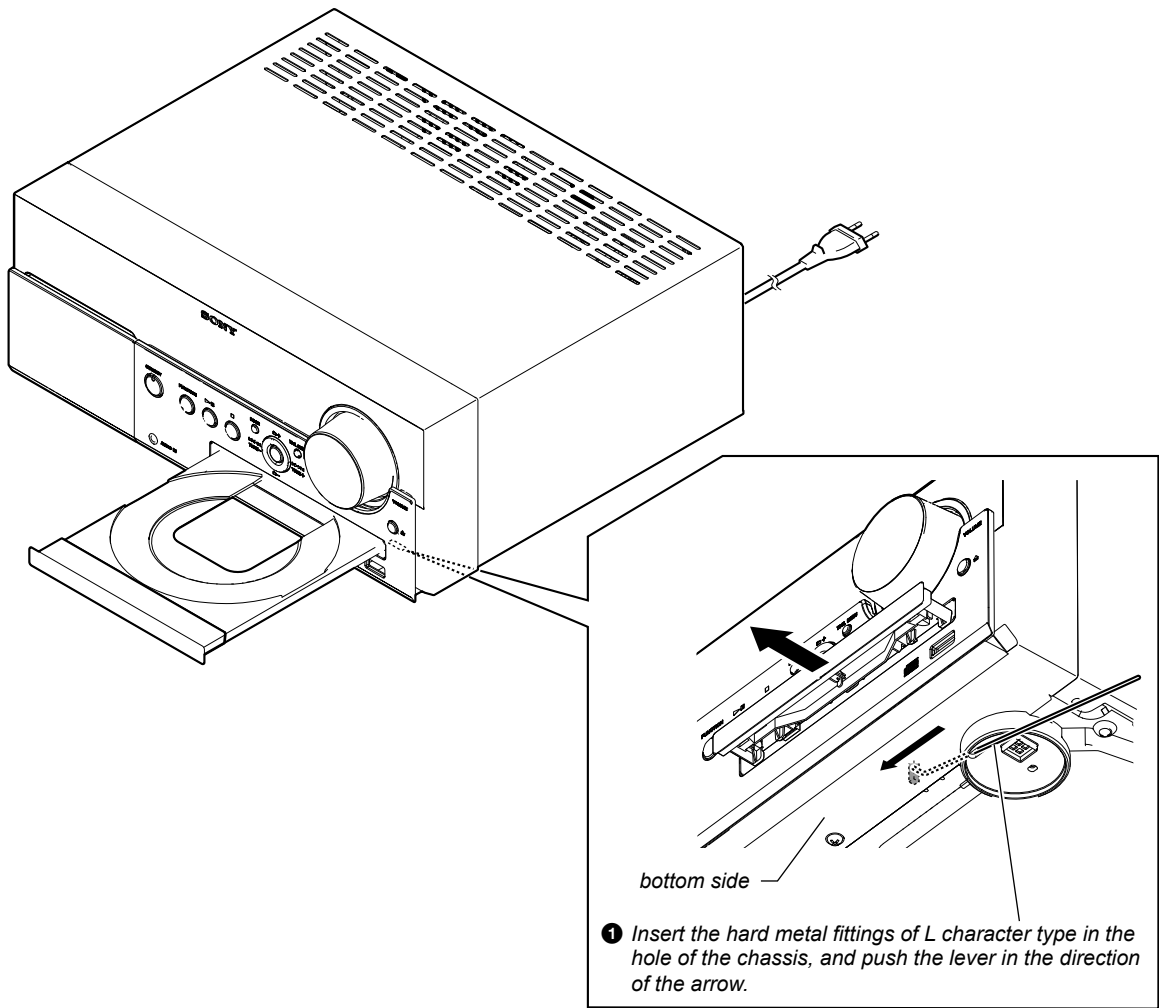

MAIN, BD96/BD96U AND SP BOARDS SERVICE POSITION

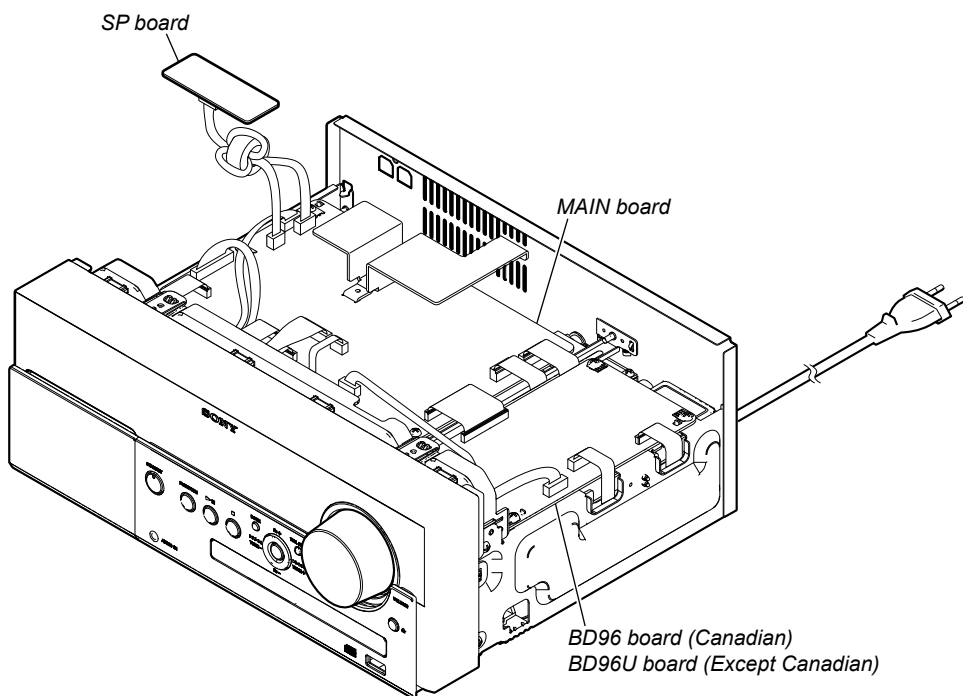

HCD-MX500i/MX550i

FL, KEY, JACK AND USB BOARDS SERVICE POSITION

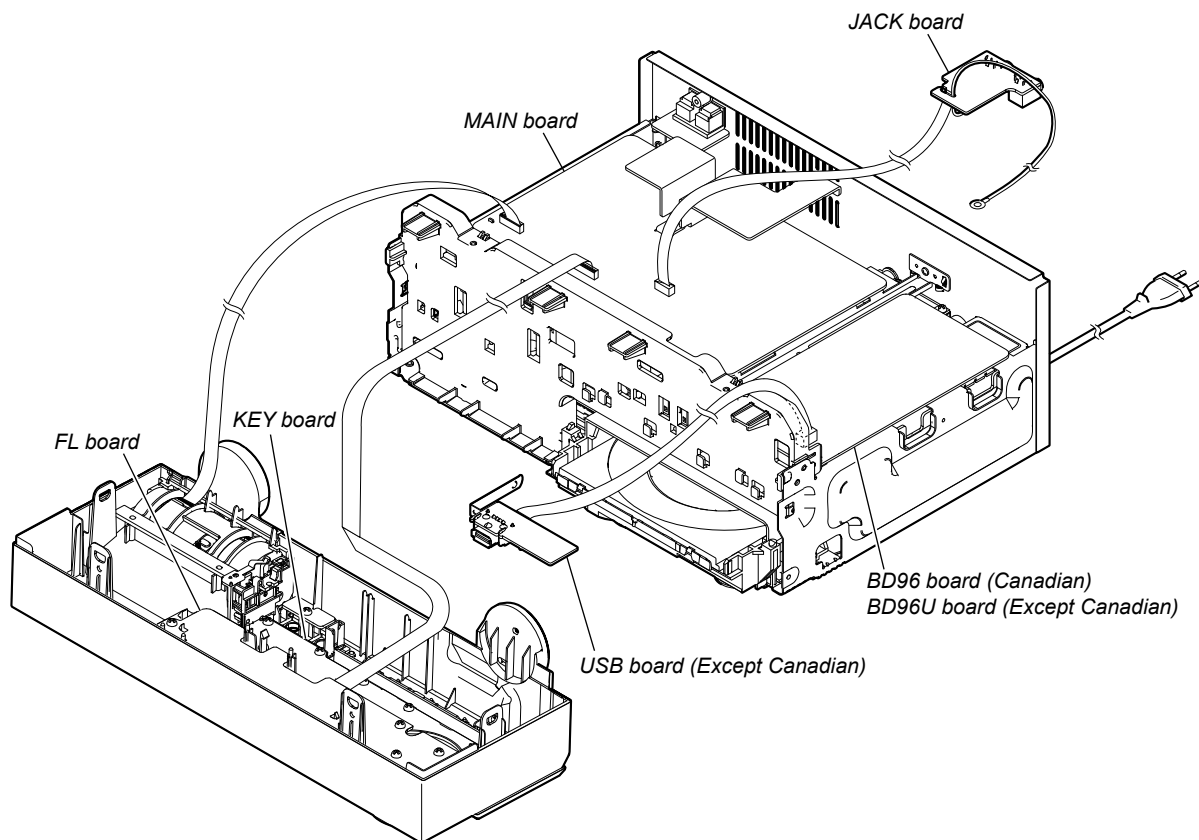

CD MECHANISM DECK, MAIN AND BD96/BD96U BOARDS SERVICE POSITION

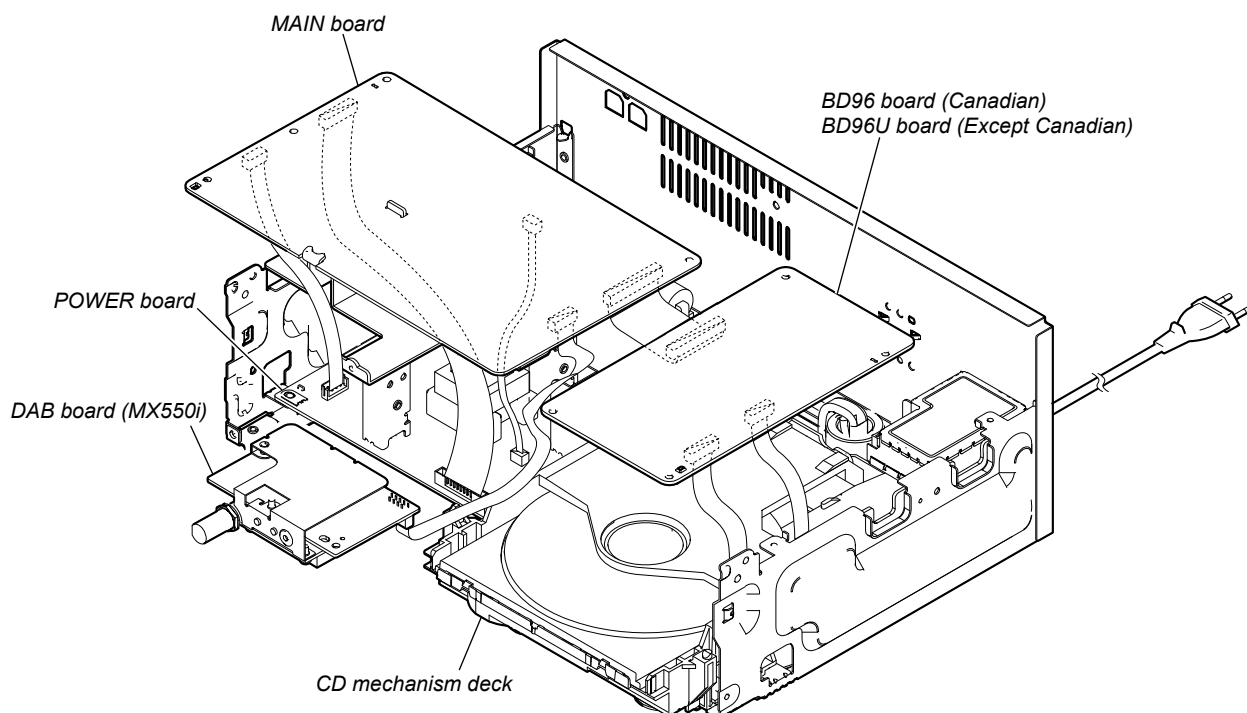

POWER BOARD SERVICE POSITION

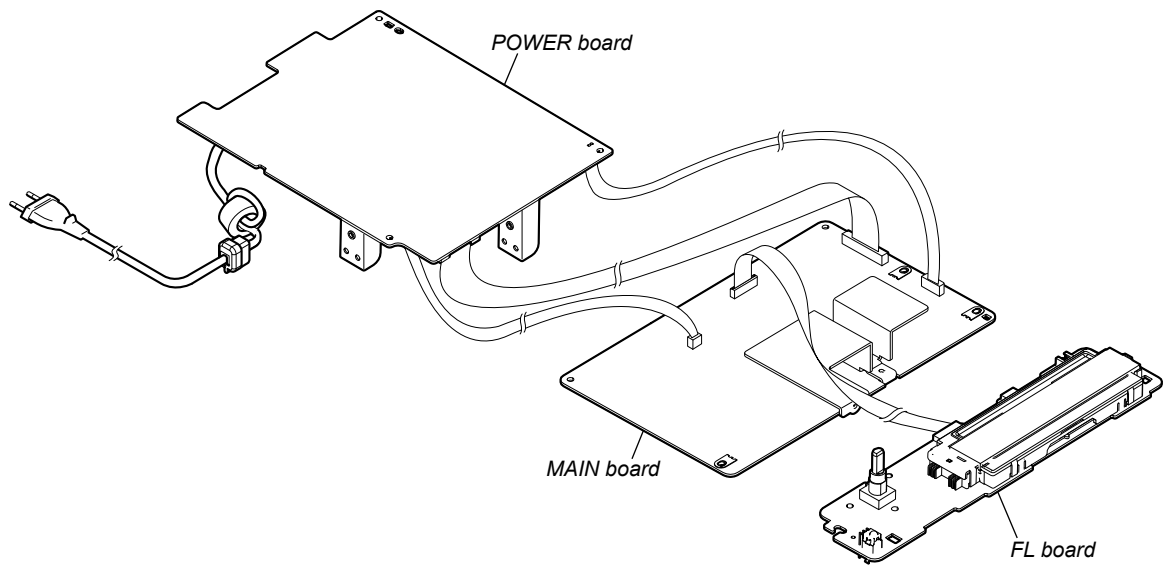

SECTION 2 DISASSEMBLY

- This set can be disassembled in the order shown below.

2-1. DISASSEMBLY FLOW

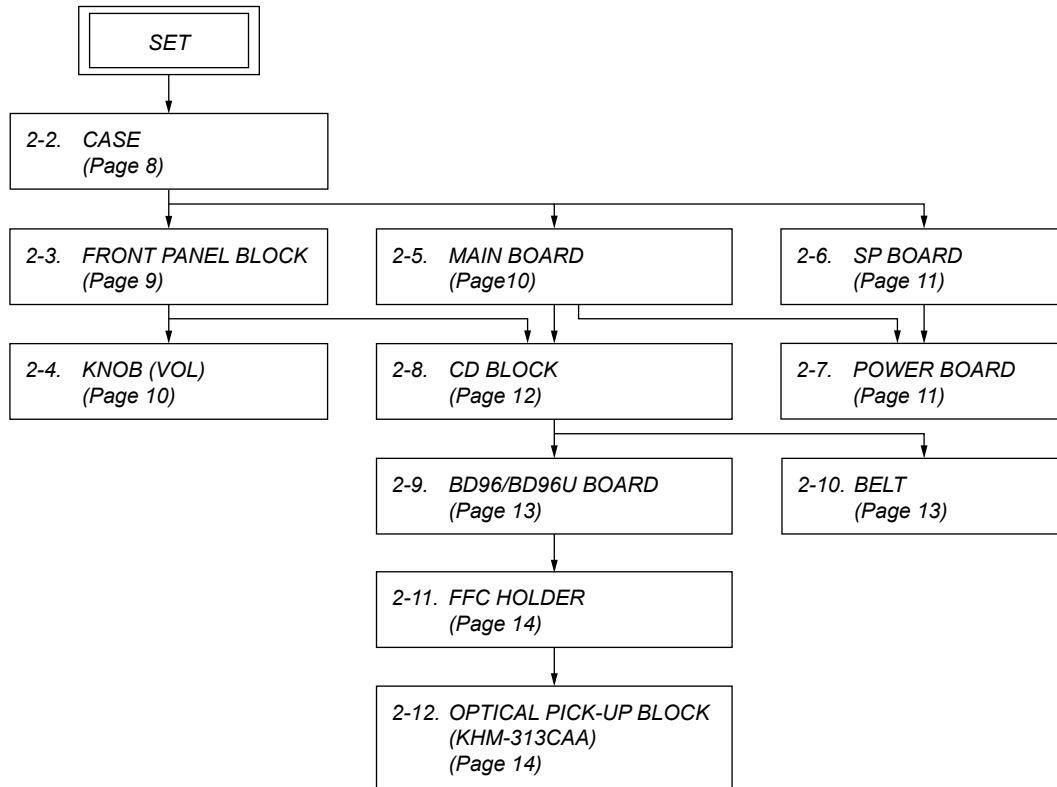

Note: Follow the disassembly procedure in the numerical order given.

2-2. CASE

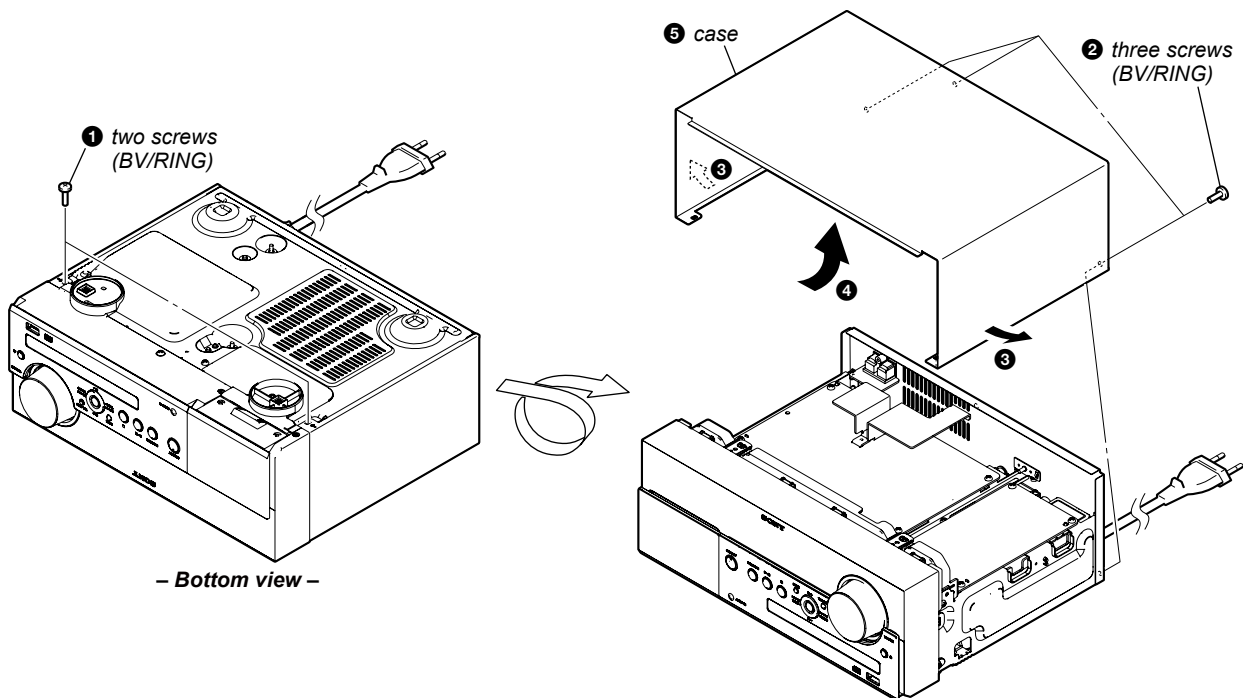

2-3. FRONT PANEL BLOCK

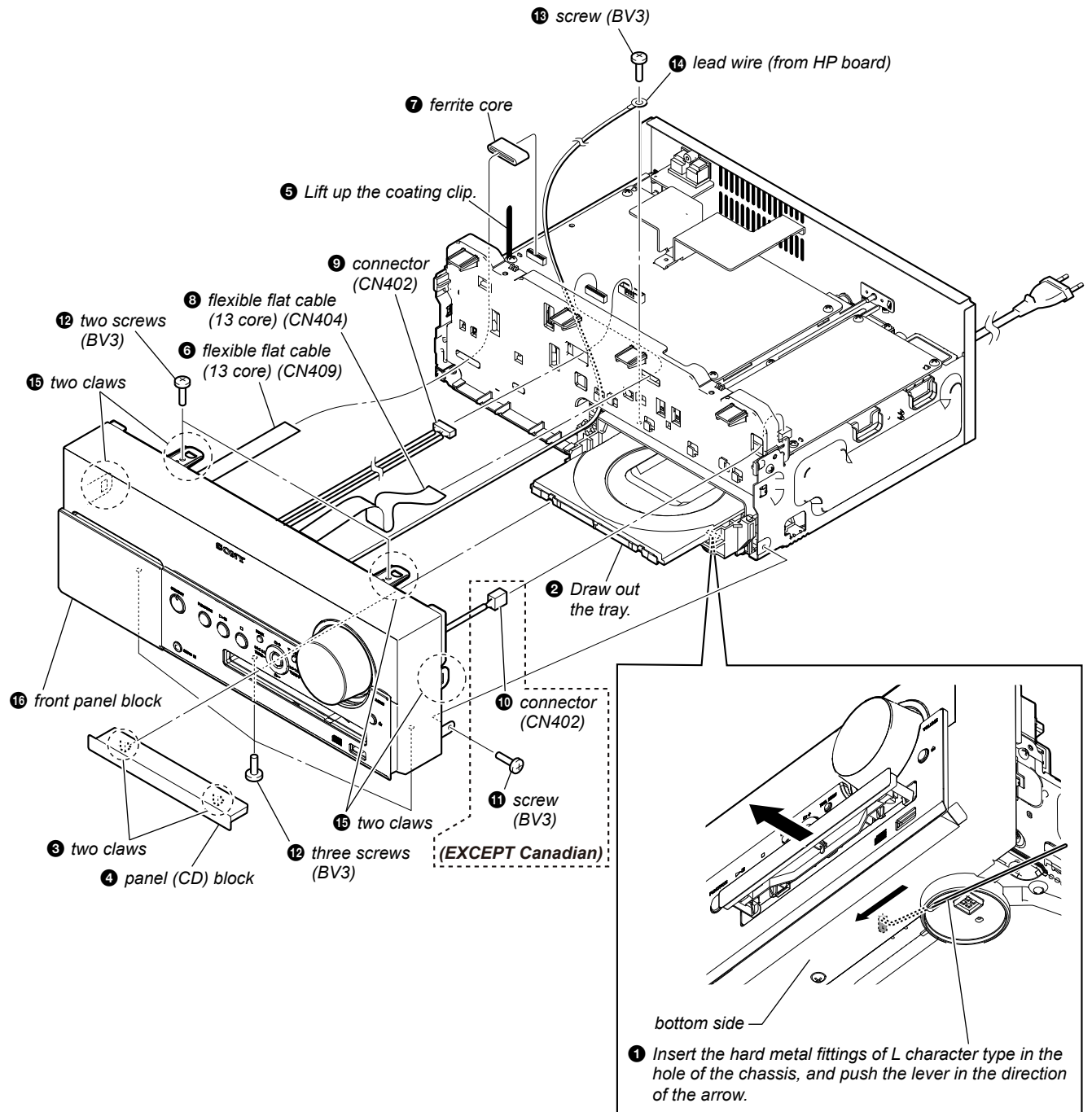

2-4. KNOB (VOL)

Note: The illustration sees the front panel block from FL board side.

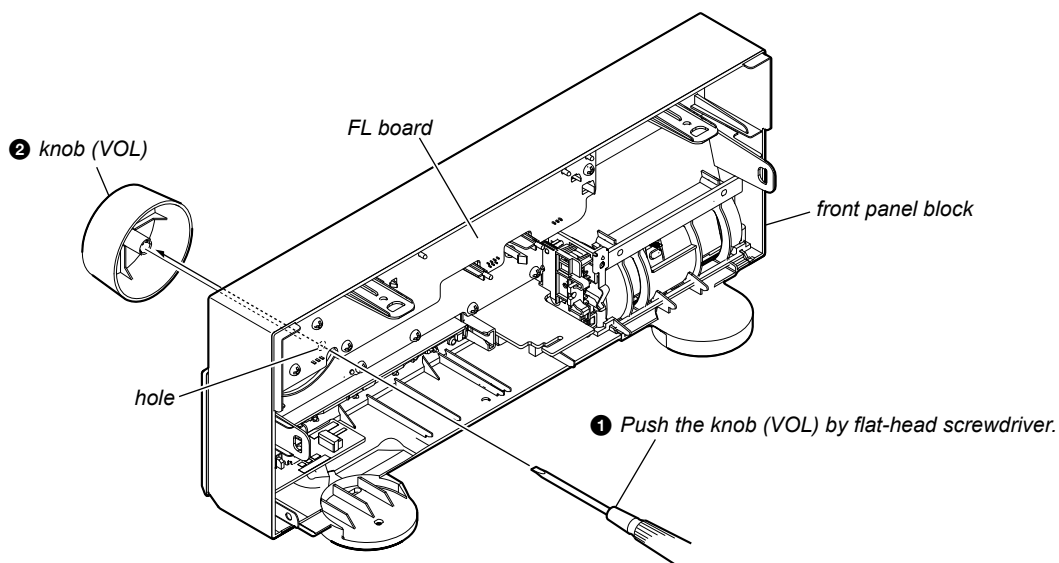

2-5. MAIN BOARD

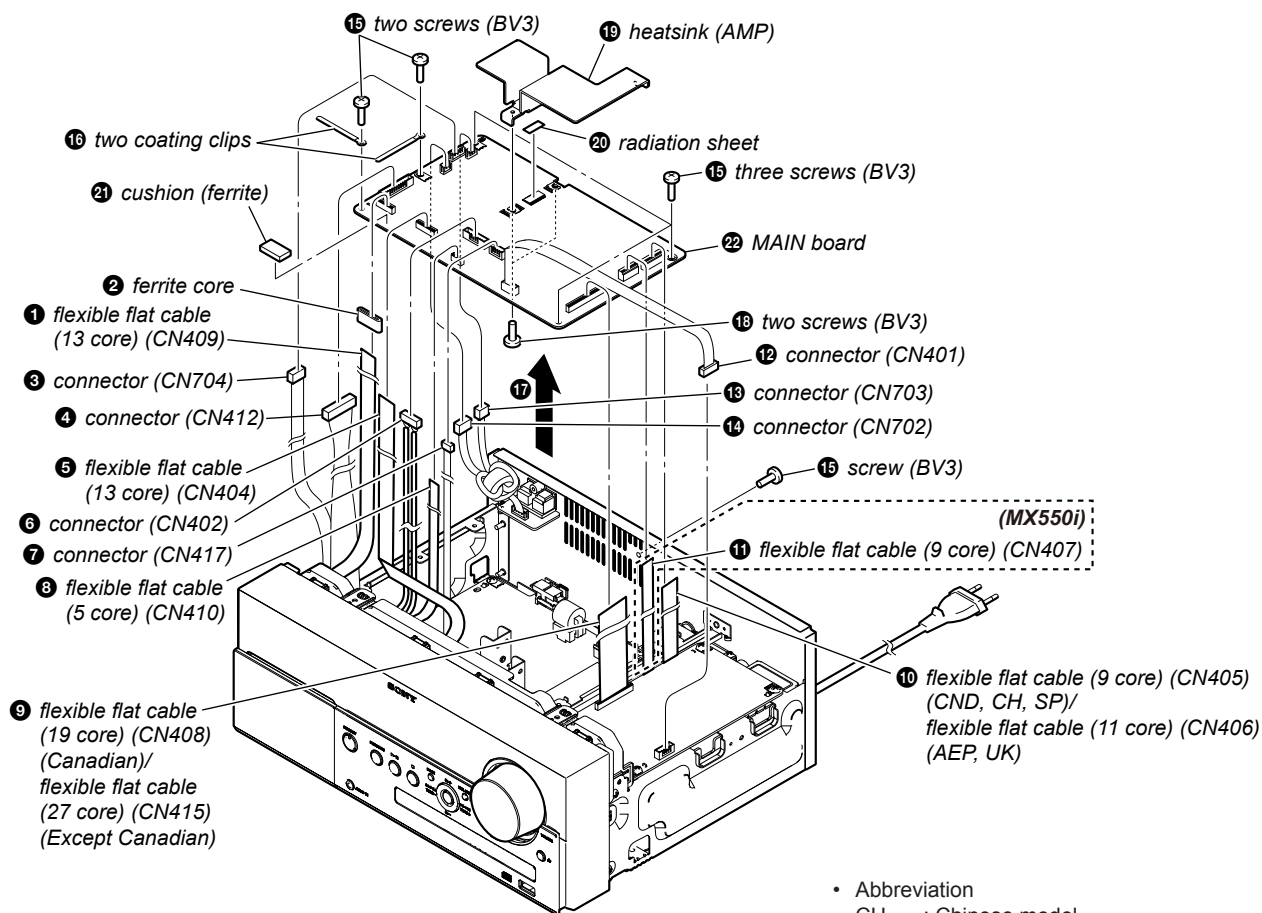

- Abbreviation
- CH : Chinese model
- CND : Canadian model
- SP : Singapore model

2-6. SP BOARD

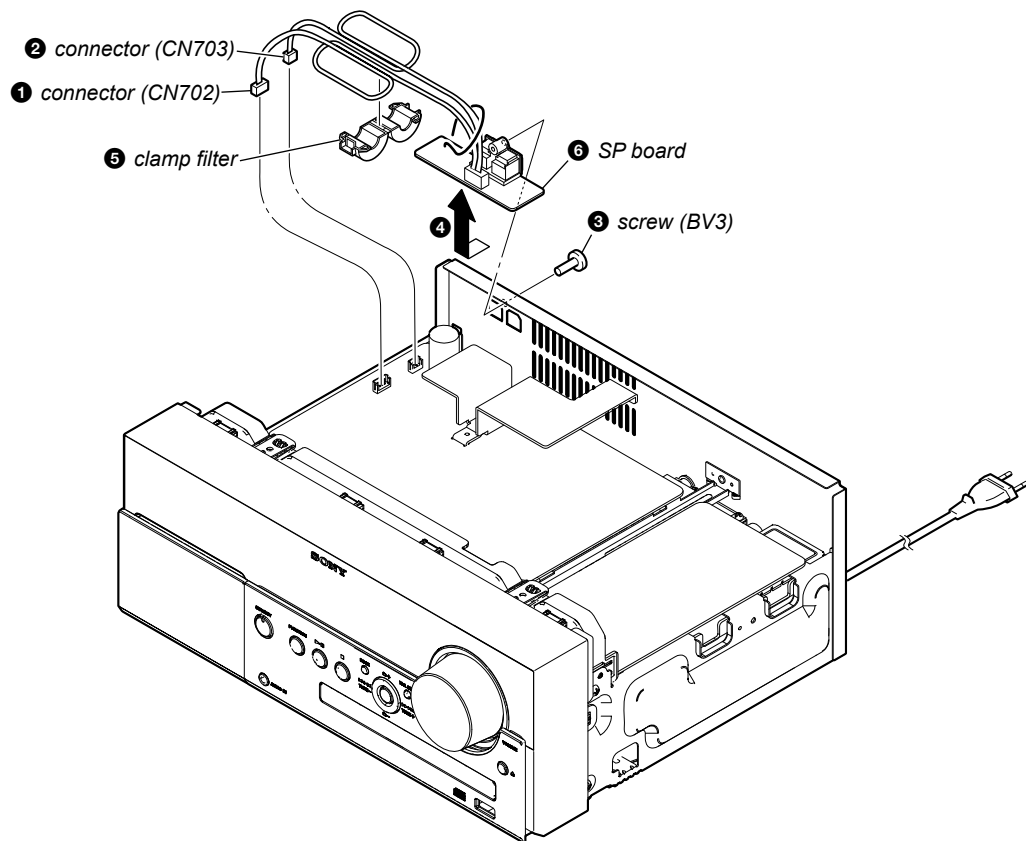

2-7. POWER BOARD

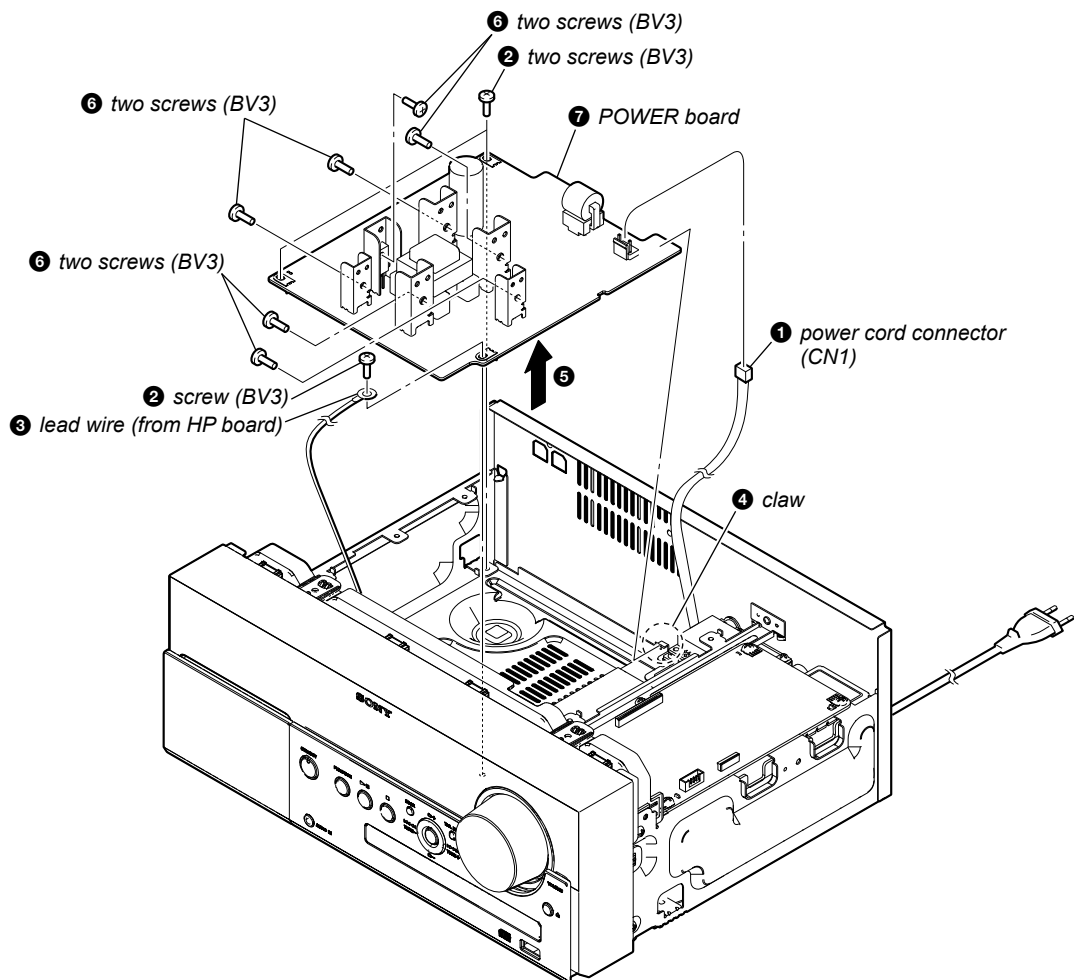

2-8. CD BLOCK

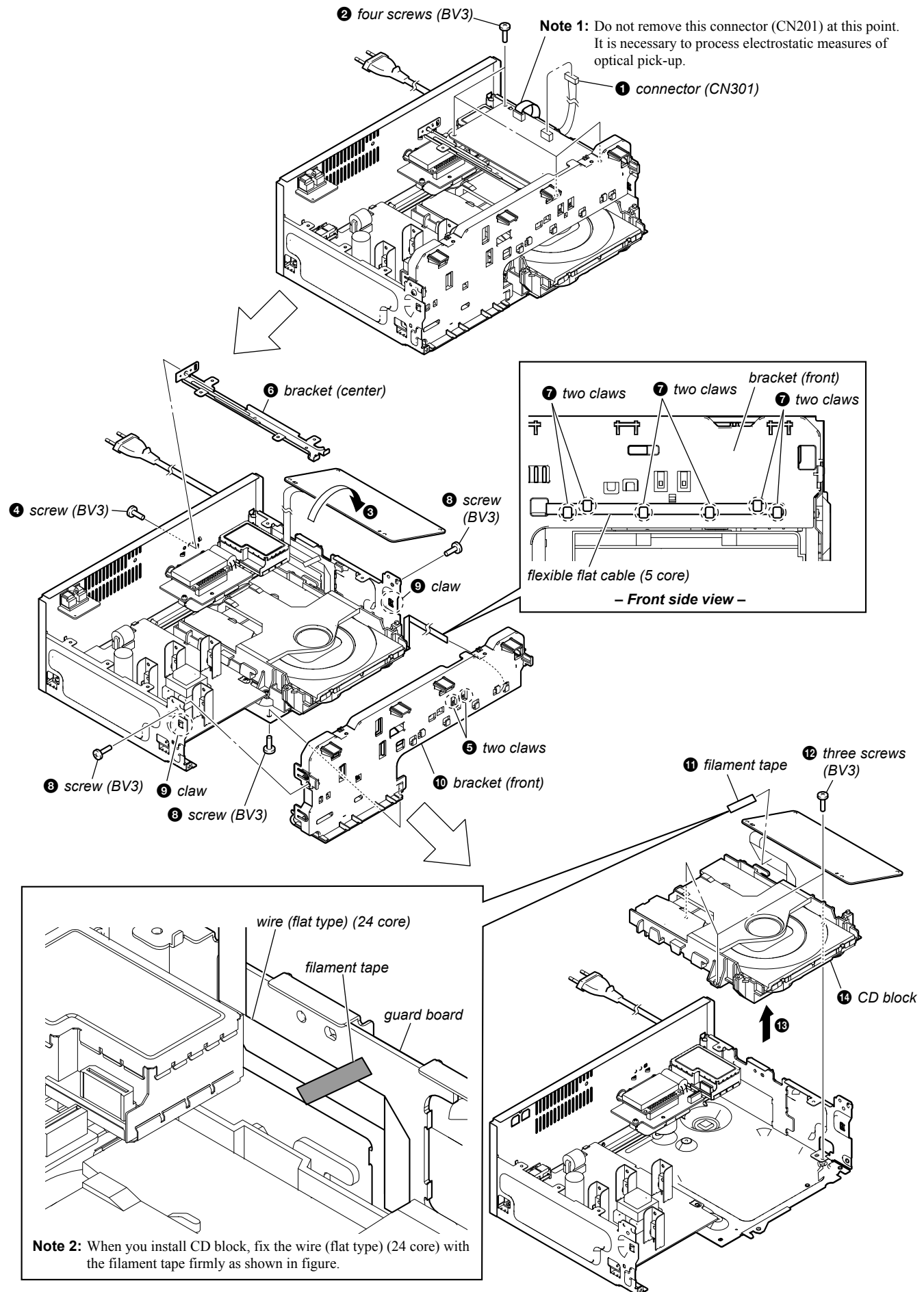

2-9. BD96/BD96U BOARD

Note 1: When disconnection the wire (flat type) (24 core) of optical pick-up block, solder the short-land.

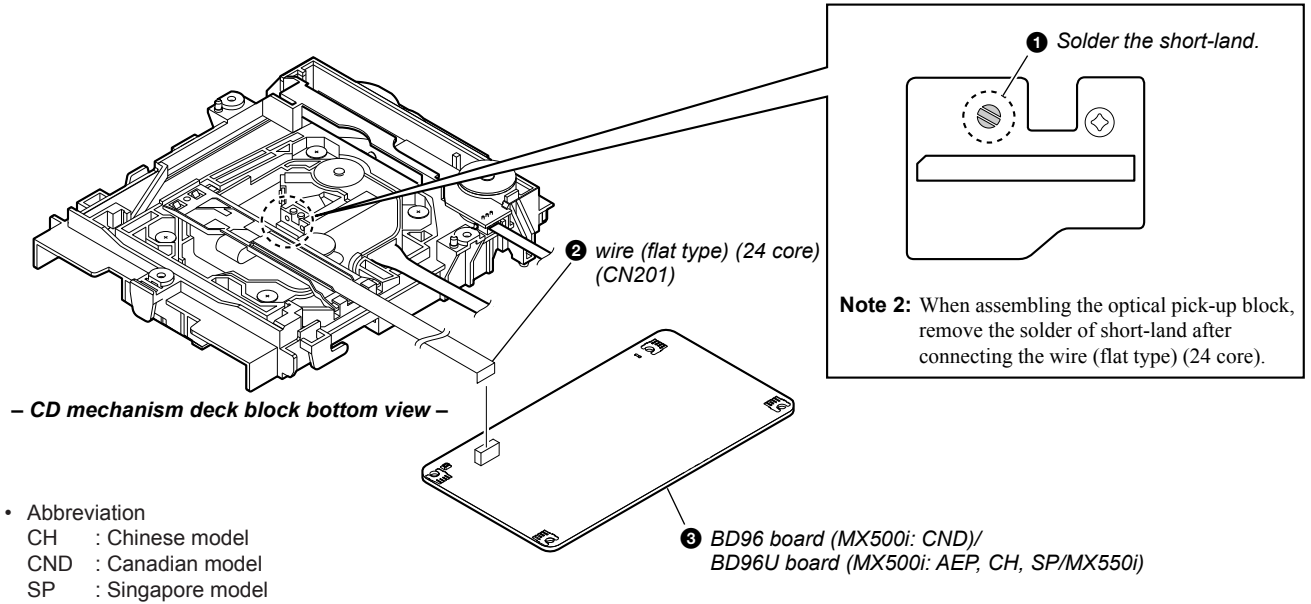

2-10. BELT

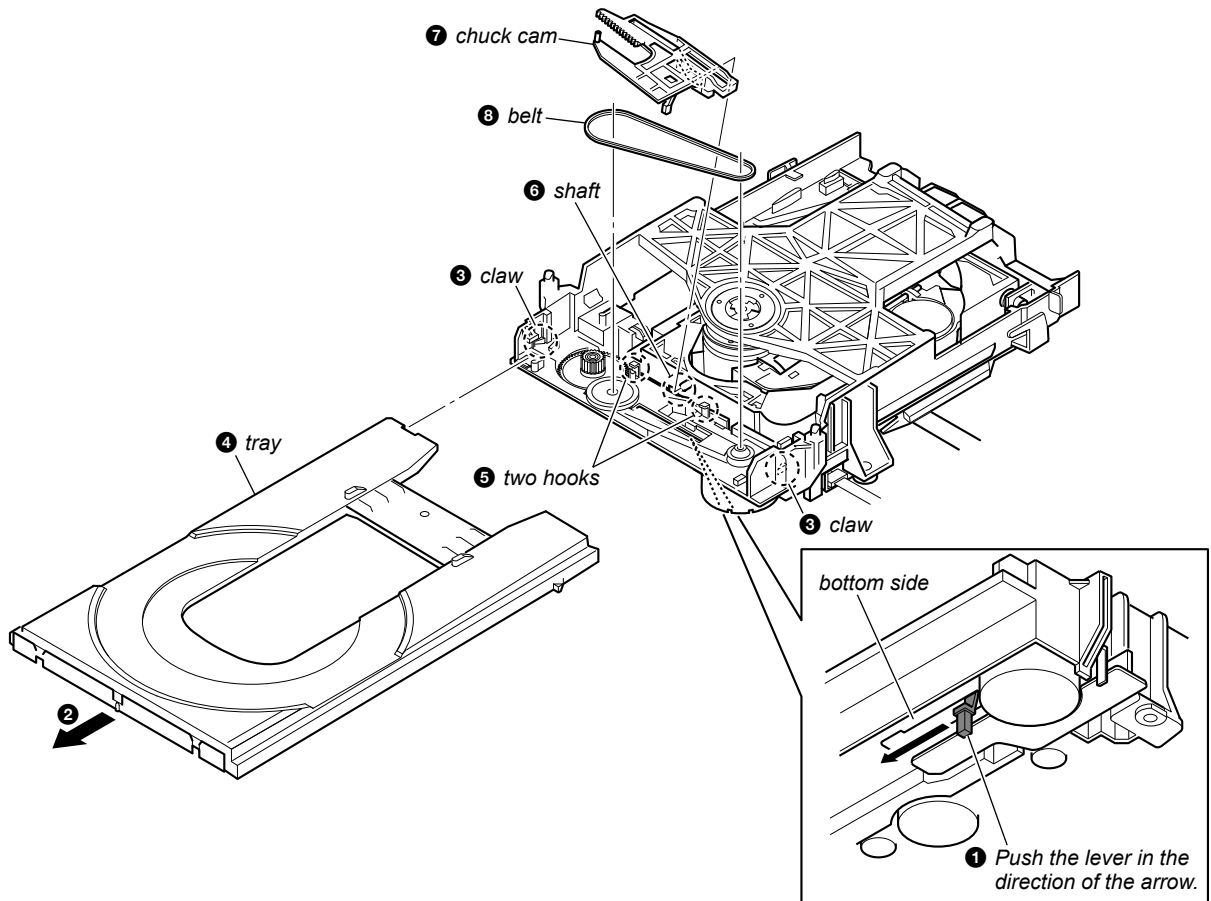

2-11. FFC HOLDER

Note 1: The illustration sees the CD mechanism deck block from optical pick-up block side.

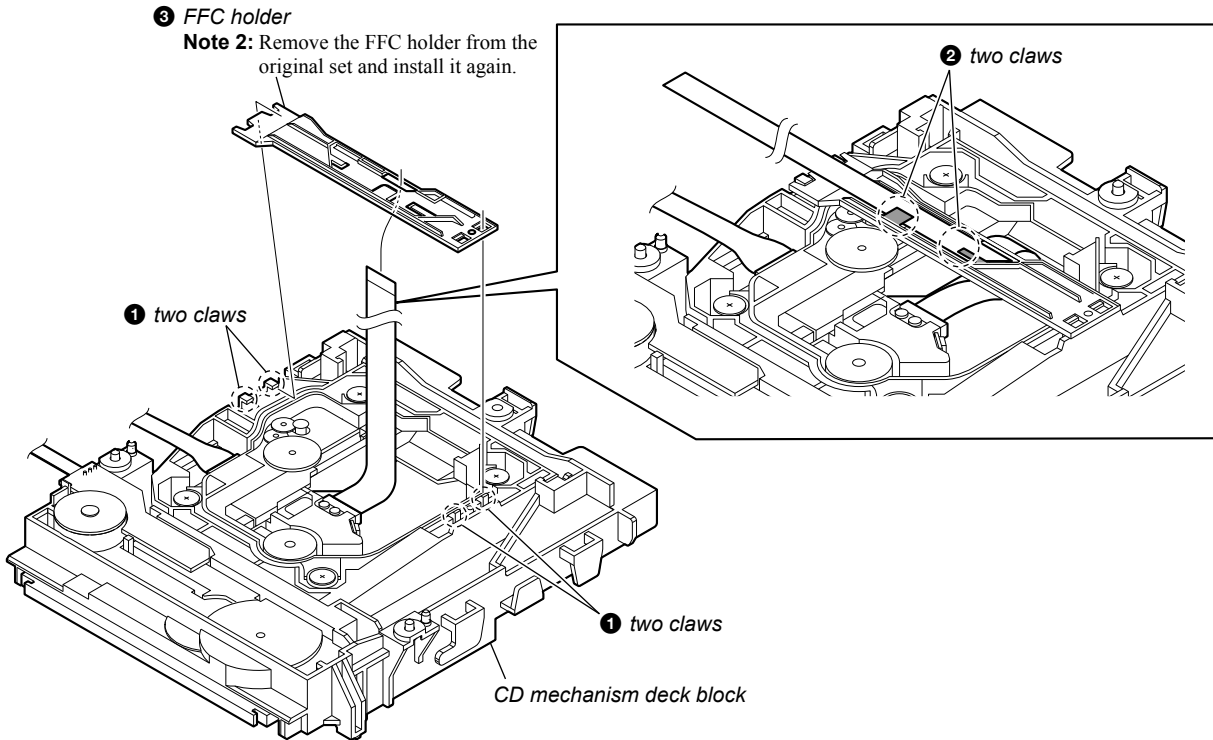

2-12. OPTICAL PICK-UP BLOCK (KHM-313CAA)

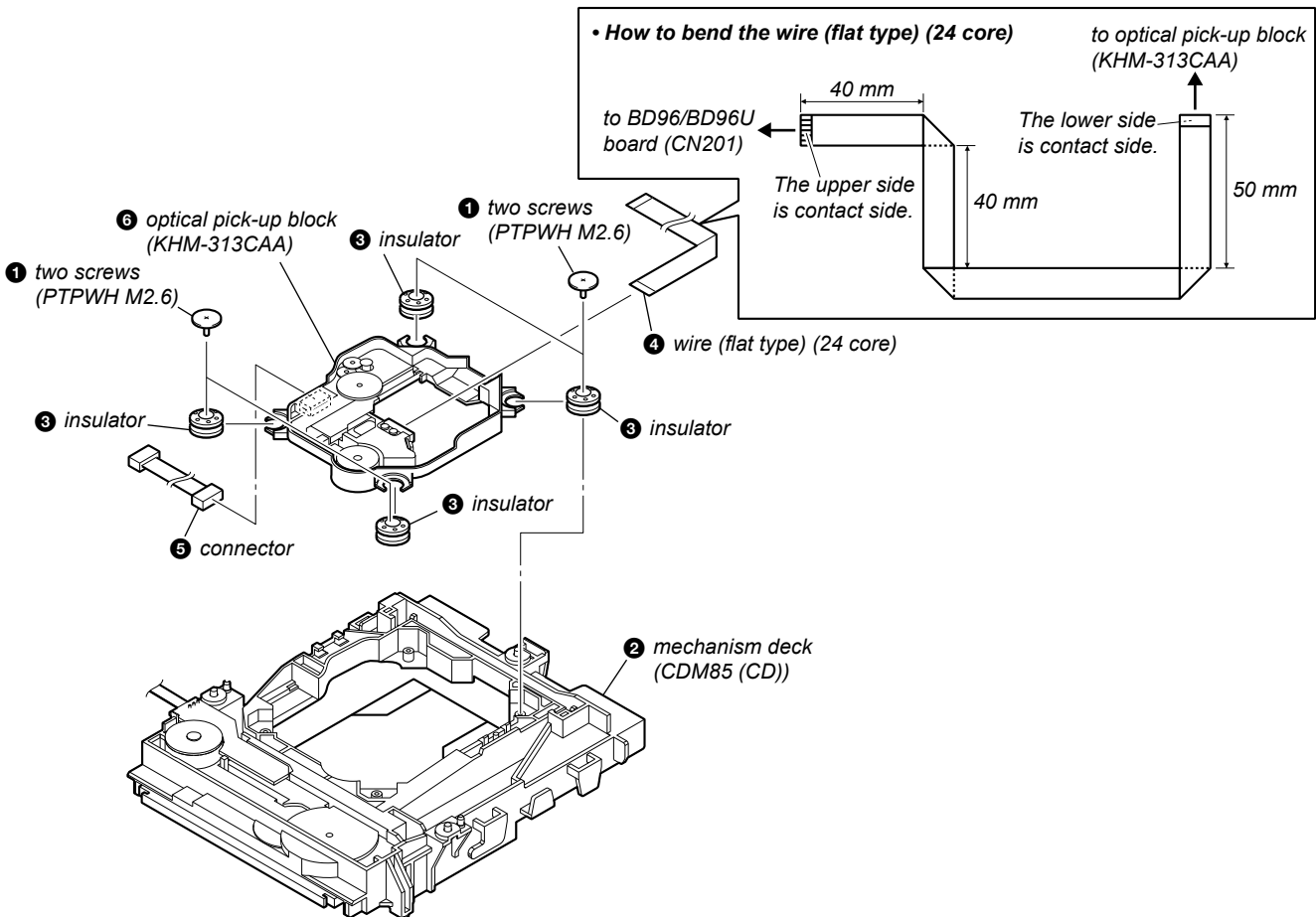

– CD mechanism deck block bottom view –

SECTION 3 TEST MODE

COLD RESET

The cold reset clears all data including preset data stored in the memory to initial conditions. Execute this mode when returning the set to the customer.

Procedure:

1. In the standby status, press the [I/⏻] button to turn the power on.
2. Press two buttons of [ENTER] and [I/⏻] simultaneously.
3. When "RESET" appears, the set enters.

AUTO STANDBY MODE

This mode is used to change the automatic standby function. With this function, the system enters standby mode automatically in about 30 minutes when there is no operation or audio signal output. By default, the automatic standby function is turned on.

Procedure:

1. Press the [I/⏻] button to turn the power on.
2. Press the [I/⏻] button for 2 seconds.
3. The message "AUTO STBY" → "OFF" is displayed on the fluorescent indicator tube and the automatic standby OFF mode is set.
4. To turn this function on, press the [I/⏻] button again for 2 seconds. The message "AUTO STBY" → "ON" is displayed on the fluorescent indicator tube and the automatic standby ON mode is set.

COMMON TEST MODE

This mode is used to check operations of amplifier.

Procedure:

1. Press the [I/⏻] button to turn the power on.
2. Press two buttons of [ENTER] and [FUNCTION] simultaneously.
3. When the COMMON test mode is activated, "AUDIO IN" is displayed on the fluorescent indicator tube and "⊖ PLAY SLEEP" blink on the fluorescent indicator tube.
4. Each time [EQ] button on the remote commander is pressed, the display changes starting "TONE MAX", "TONE MIN" and "TONE FLAT" this order.
5. Turn the [VOLUME] knob counterclockwise, "VOLUME MIN" is displayed on the fluorescent indicator tube. Turn the [VOLUME] knob clockwise, "VOLUME MAX" is displayed on the fluorescent indicator tube.
6. To release this mode, press the [I/⏻] button.

PANEL TEST MODE

This mode is used to check the fluorescent indicator tube, LED, model, destination, software version and key.

Procedure:

1. Press the [I/⏻] button to turn the power on.
2. Press three buttons of [ENTER] and [■] simultaneously.
3. All segments on the fluorescent indicator tube, [STANDBY] LED light up.
4. Press the [ENTER] button, the model and destination are displayed on the fluorescent indicator tube.
5. Press the [ENTER] button again, MC version is displayed on the fluorescent indicator tube.
6. Each time [ENTER] button is pressed, the display changes starting from MC version, GC version, USBL version, USBM version, IPL version, CD version, CDD version, CDMA version, CDMA version, BDA version, BDB version, ST version, TA version and TM version this order, and returns to the MC version display.
7. When [■] button is pressed while the MC version is displayed, year, month and day of the software creation is displayed. When [■] button is pressed again, the display returns to the MC version display.

8. Press the [TOOL MENU] button, the key test mode is activated and "K 0 V0" is displayed on the fluorescent indicator tube.
9. Each time a button is pressed, "K" value increases. However, once a button is pressed, it is no longer taken into account. All keys are pressed, display becomes "K9".
10. "V" value increases 2, 4, 6 ... if turn the [VOLUME] knob clockwise, or it decreases 8, 6, 4 ... if turn the knob counterclockwise.
11. To release this mode, press three buttons in the same manner as step 2, or disconnect the power cord.

CD SHIP MODE

This mode moves the optical pick-up to the position durable to vibration. Use this mode when returning the set to the customer after repair.

Procedure:

1. Press the [I/⏻] button to turn the power on.
2. Press the [FUNCTION] button to select "CD".
3. Press two buttons of [TOOL MENU] and [I/⏻] simultaneously.
4. After blink "STANDBY", "LOOK" is displayed, disconnect the AC plug.

CD SHIP MODE & MEMORY CLEAR

This mode is used to perform CD ship mode and cold reset simultaneously.

Procedure:

1. Press the [I/⏻] button to turn the power on.
2. Press three buttons of [■] and [DSGX] simultaneously.
3. After blink "STANDBY", "LOOK" is displayed disconnect the AC plug.

ANTITHEFT LOCK MODE

This mode is used to unable to take sample disc out of disc tray in the shop.

Procedure:

1. Press the [I/⏻] button to turn the power on.
2. Press the [▲] button to open the disc tray and set the CD disc.
3. Press the [▲] button to close the disc tray.
4. Press two buttons of [■] and [▲] for 5 seconds.
5. The message "LOCKED" is displayed on the fluorescent indicator tube and the disc tray is locked. (Even if pressing the [▲] button, the message "LOCKED" is displayed on the fluorescent indicator tube and the disc tray is locked)
6. To release from this mode, press two buttons of [■] and [▲] for 5 seconds.
7. The message "UNLOCKED" is displayed on the fluorescent indicator tube and the disc tray is unlocked.

CD POWER MANAGE

This mode is used to changed over CD power on/off for decreasing of reception noise in the tuner mode.

Procedure:

1. Press the [I/⏻] button to turn the power on.
2. Press the [FUNCTION] button to select "CD".
3. Press the [I/⏻] button again to turn the power off.
4. Press two buttons of [☐ + ▲] and [I/⏻] simultaneously.
5. The message "CD POWER ON" or "CD POWER OFF" is displayed on the fluorescent indicator tube, and CD power on/off is changed over in the tuner mode.

CD SERVICE MODE

This mode can run the CD sled motor freely. Use this mode, for instance, when cleaning the optical pick-up.

Procedure:

1. Press the [I/⏻] button to turn the power on.
2. Press the [FUNCTION] button to select "CD".
3. Press three buttons of [■] and [□ + ▲] simultaneously, the message "SERVICE MO" is displayed on the fluorescent indicator tube.
4. Press the [◀◀ TUNE -] button to move the optical pick-up to inside track and the message "SLED IN" is displayed on the fluorescent indicator tube, or press the [▶▶ TUNE +] button to outside track and the message "SLED OUT" is displayed on the fluorescent indicator tube.
5. Press the [▶▶] button, "LD ON" or "LD OFF" is displayed on the fluorescent indicator tube. Each time [▶▶] button is pressed, laser diode on/off is changed over.
6. To release this mode, press the [I/⏻] button.

CD SERVO TEST MODE

This mode can check the servo system operations of the optical pick-up system (= optical unit + BD96/BD96U board).

Note 1: Do not enter the [CD SERVO TEST MODE] while any other test mode is in progress.

Note 2: Do not enter any other test mode while the [CD SERVO TEST MODE] is in progress.

Note 3: In RAM Read, "SBADrough", "SBBTrough", "DT-GI roug", "SBAD fine", "SBBT fine", "DT-GI fine", "DSPcomcnt", and "EDCcomcnt" are displayed but are not used in the service.

How to Enter the CD Servo Test Mode

Procedure:

1. Press the [I/⏻] button to turn the power on.
2. Press the [FUNCTION] button to select CD function.
3. Press three buttons of [■], and [▼ □ -] simultaneously.
4. It enters the CD servo test mode and displays "bdt S CURV".

How to Exit from the CD Servo Test Mode

Procedure:

1. To release this mode, press the [I/⏻] button.

Key Operation:

[□ + ▲], [▼ □ -]:

Use these keys to move between the seven modes contained in the CD Servo Test Mode, that are the S-Curve Mode, the RAM Read Mode, the RAM Write Mode, the Command Out Mode, the Error Rate Mode the LOG Initialize Mode and the LOG Read Mode as described below. Also, use these keys to move between the menus within the respective seven modes. When [□ + ▲] is pressed, the screen advances to the next menu or to the next mode. When [▼ □ -] is pressed, the screen returns back to the previous menu or to the previous mode. Use these keys also to increase or decrease the numeric value when changing the numeric value. Pressing [□ + ▲] increases the value and pressing [▼ □ -] decreases the value.

[ENTER], [■]:

Use these keys to move between the different layers of the hierarchy of the CD Servo Test Mode shown below. Press [ENTER] to move down to the lower layer, and press [■] to move up to the higher layer.

[▶▶ TUNE +], [◀◀ TUNE -]:

Use these keys to move the cursor to the right digit or to the left digit in the six-digit number, when changing the numeric value.

Press [▶▶ TUNE +] to move the cursor to the right, and press [◀◀ TUNE -] to return the cursor to the left.

[▶▶]:

Use this key to execute Command Out in the Command Out Mode.

CD Servo Test Mode Tree:

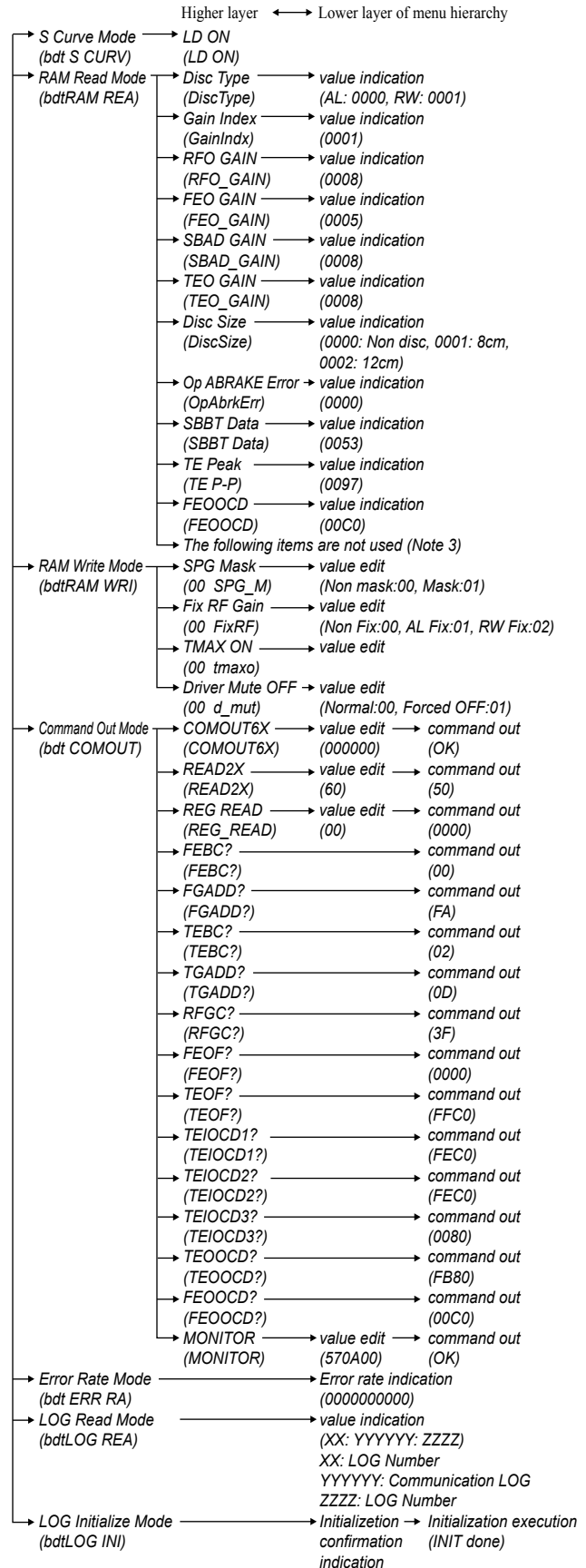

CD ERROR CODE

The past errors of the CD mechanism (CDM) are displayed as the CDM Errors, and those of the optical pick-up system (= optical unit + BD96/BD96U board) are displayed as the BD Errors as shown below.

Procedure:

1. Press the [I/⏻] button to turn the power on.
2. Press the [FUNCTION] button to select CD function.
3. Press three buttons of [TOOL MENU] and [▶▶] simultaneously.
4. BD and CDM error counts are displayed on the fluorescent indicator tube as shown below.

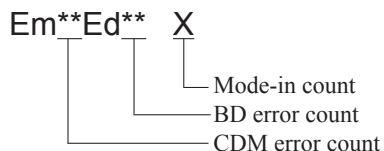

5. Press the [⏏ + ▲] button.
6. Then, the CDM error code is displayed as “M0xxxxxxx” (x means hexadecimal number) on the fluorescent indicator tube as shown below.
7. Every pressing of the [▶▶ ▷▷▶ TUNE +] button in this mode increments the number after “M” starting from “M0” up to “M9”, and then returns to “M0”. Every pressing of the [◀◀◀ TUNE -] button in this mode decrements the number after “M”. The smaller the error code number is, the newer the error content is.
Press the [▼ ⏏ -] button to return to the previous display.
8. When the [⏏ + ▲] button is pressed then, the BD error code is displayed as “D0xxxxxxx” (x means hexadecimal number) on the fluorescent indicator tube as shown below. In the same way as the CDM error code, use of the [▶▶ ▷▷▶ TUNE +] and the [◀◀◀ TUNE -] buttons in this mode enables tracing of the error history.
Press the [▼ ⏏ -] button to return to the previous display.
9. To release from this mode, press the [I/⏻] button to turn the power off.

Contents of “CDM Errors”

Error display example

M 0 FF 11 42 00
① ② ③ ④ ⑤

- ① It indicates the error history number
0 to 9: The error code number 0 indicates the newest error.
- ② It indicates whether the CDM error occurs in the normal operations or during the initialization operation.
FF : The error has occurred in the normal operations.
Other than FF: The error has occurred during the initialization operation.
- ③ It indicates the processing during which the trouble has occurred.
01: The disc EJECT processing is in progress.
02: The disc INSERTION-WAITING processing is in progress.
03: Processing of the disc INSERTION-REQUEST for the upper CD tray is in progress.
04: Processing of the disc EJECTION-REQUEST for the upper CD tray is in progress.
05: The disc pulling-in operation is in progress.
06: The disc chucking processing is in progress.
07: The disc re-chucking processing is in progress.

08: The disc chucking-release completion operation is in progress.

- ④ It indicates the operation during which the trouble has occurred.
00 : Waiting for the operation.
10 to 13 : The disc EJECT operation is in progress.
20 : The disc pulling-in operation is in progress.
30 : The disc chucking-release operation is in progress.
40 to 43 : The disc EJECT operation due to error is in progress.
- ⑤ Reserve
00: Fix

Contents of “BD Errors”

Error display example

D 0 02 09 01 01
① ② ③ ④ ⑤

- ① It indicates the error history number
0 to 9: The error code number 0 indicates the newest error.
- ② It indicates the error content
01: The focus servo cannot lock-in.
02: GFS is no good (NG).
03: The startup time exceeds the specified period of time (time over)
04: The focus servo is unlocked continuously.
05: Q code cannot be obtained within the specified period of time.
06: The tracking servo cannot lock-in.
07: Blank disc
- ③ It indicates the on-going processing of optical pick-up system (= optical unit + BD96/BD96U board) when the trouble has occurred.
01: The CD SHIP mode processing is in progress.
02: The POWER OFF processing is in progress.
03: The INITIALIZE processing is in progress.
04: The optical pick-up system (= optical unit + BD96/BD96U) is in the stop state.
05: The STOP operation is in progress.
06: The startup processing is in progress.
07: The TOC read-in processing is in progress.
08: The SEARCH operation is in progress.
09: The PLAY operation is in progress.
0A: The PAUSE operation is in progress.
0B: The PLAY – MANUAL SEARCH operation is in progress.
0C: The PAUSE – MANUAL SEARCH operation is in progress.
- ④ It indicates the disc speed when the trouble has occurred.
It indicates the step number of each processing specified by ③.
Because the numbers of steps are different in each processing, this number is different in each processing.
- ⑤ It indicates the disc speed when the trouble has occurred.
01: 1x (normal)

SECTION 4 ELECTRICAL CHECK

FM TUNE LEVEL CHECK

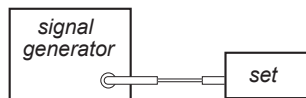

Procedure:

1. Turn on the set.
2. Input the following signal from signal generator to FM antenna input directly.

Carrier frequency : A = 87.5 MHz, B = 98 MHz, C = 108 MHz

Deviation : 75 kHz

Modulation : 1 kHz

ANT input : 35 dBu (EMF)

Note: Use 75 ohm coaxial cable to connect signal generator and the set.
You cannot use video cable for checking.
Use signal generator whose output impedance is 75 ohm.

3. Set to FM tuner function and tune A, B and C signals.
4. Confirm "TUNED" is lit on the display for A, B and C signals.

When the selected station signal is received in good condition, "TUNED" is displayed.

SECTION 5 DIAGRAMS

5-1. BLOCK DIAGRAM - CD, USB Section -

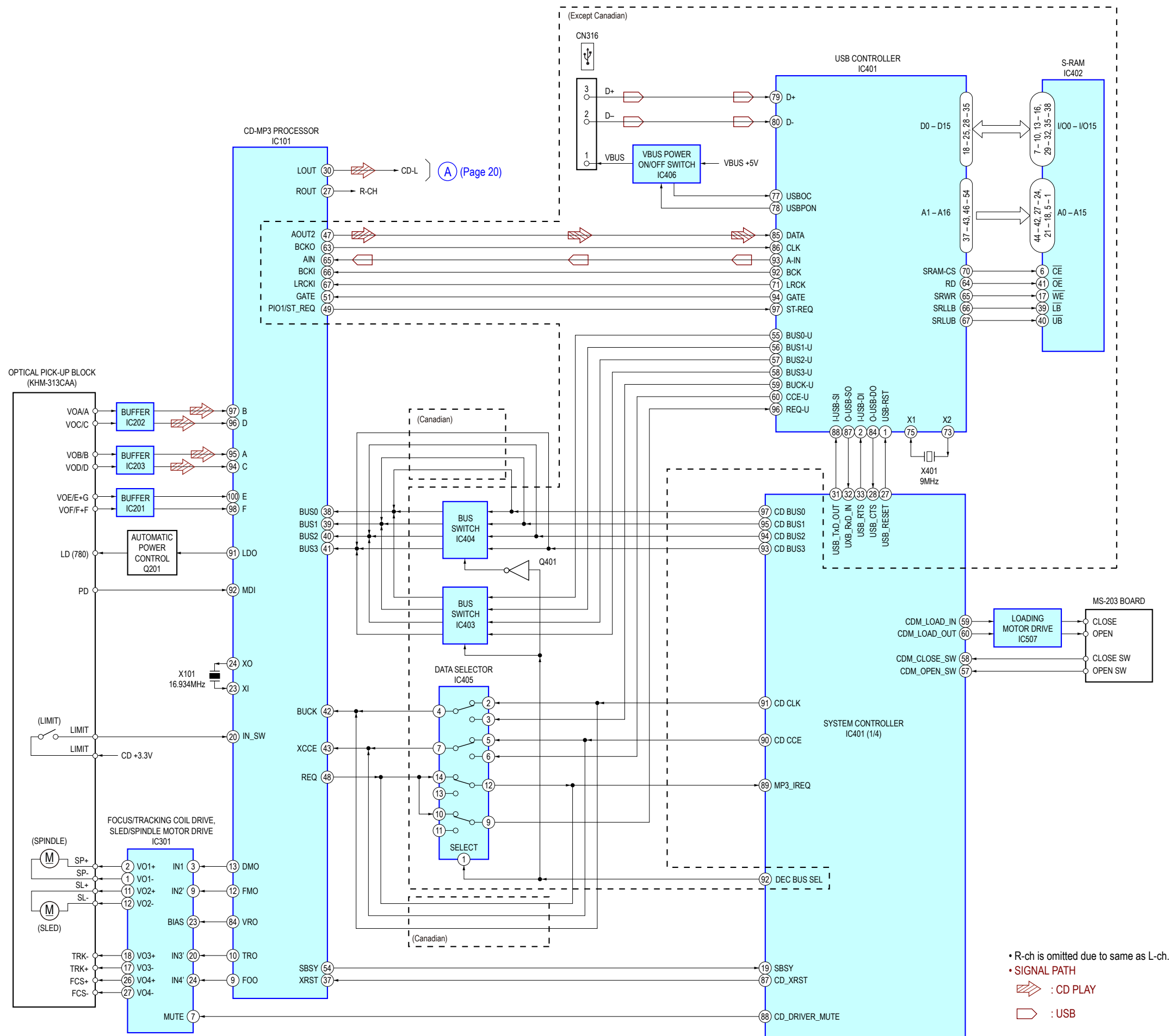

5-2. BLOCK DIAGRAM - TUNER, iPod/iPhone, AUDIO IN Section -

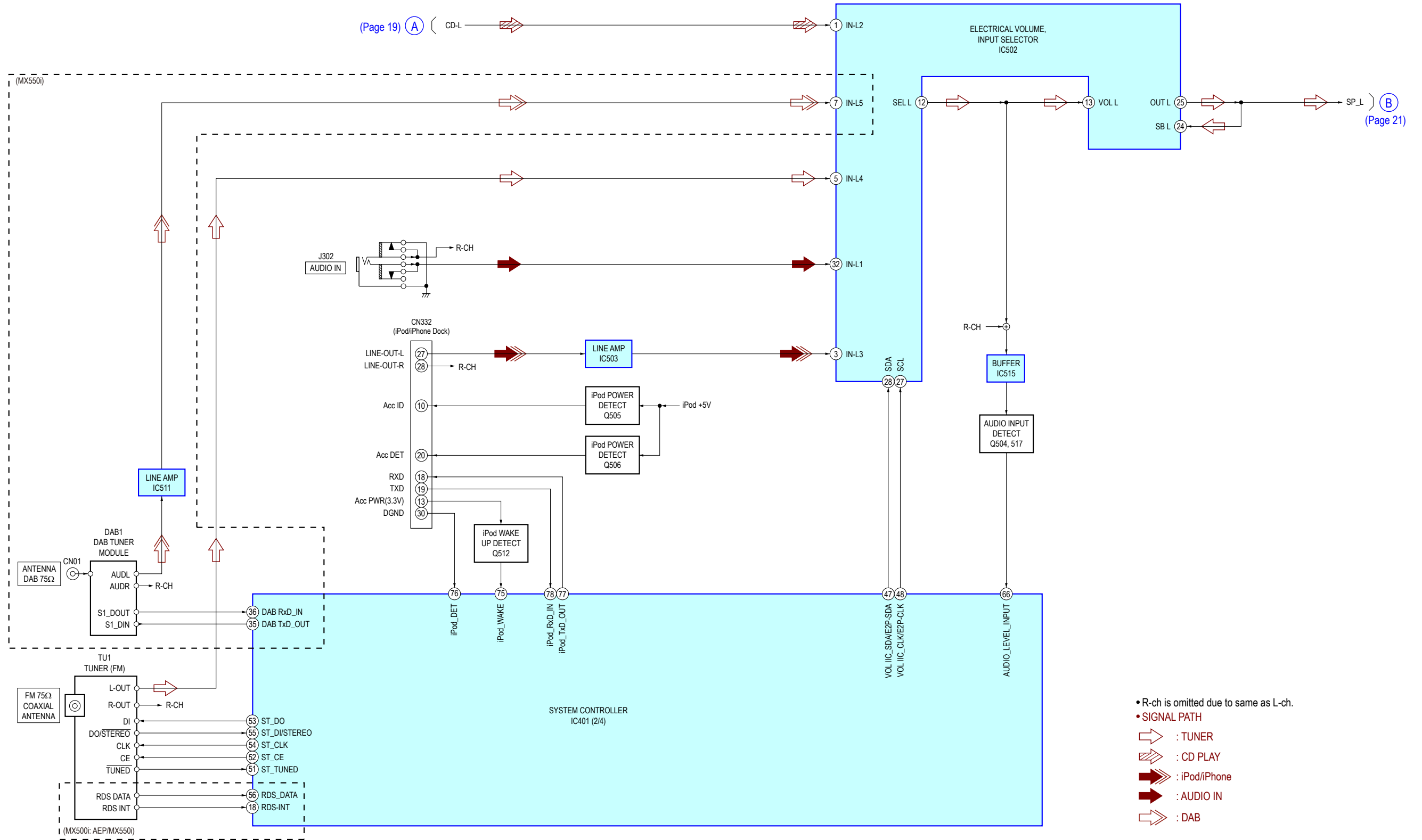

5-3. BLOCK DIAGRAM - OUTPUT, PANEL Section -

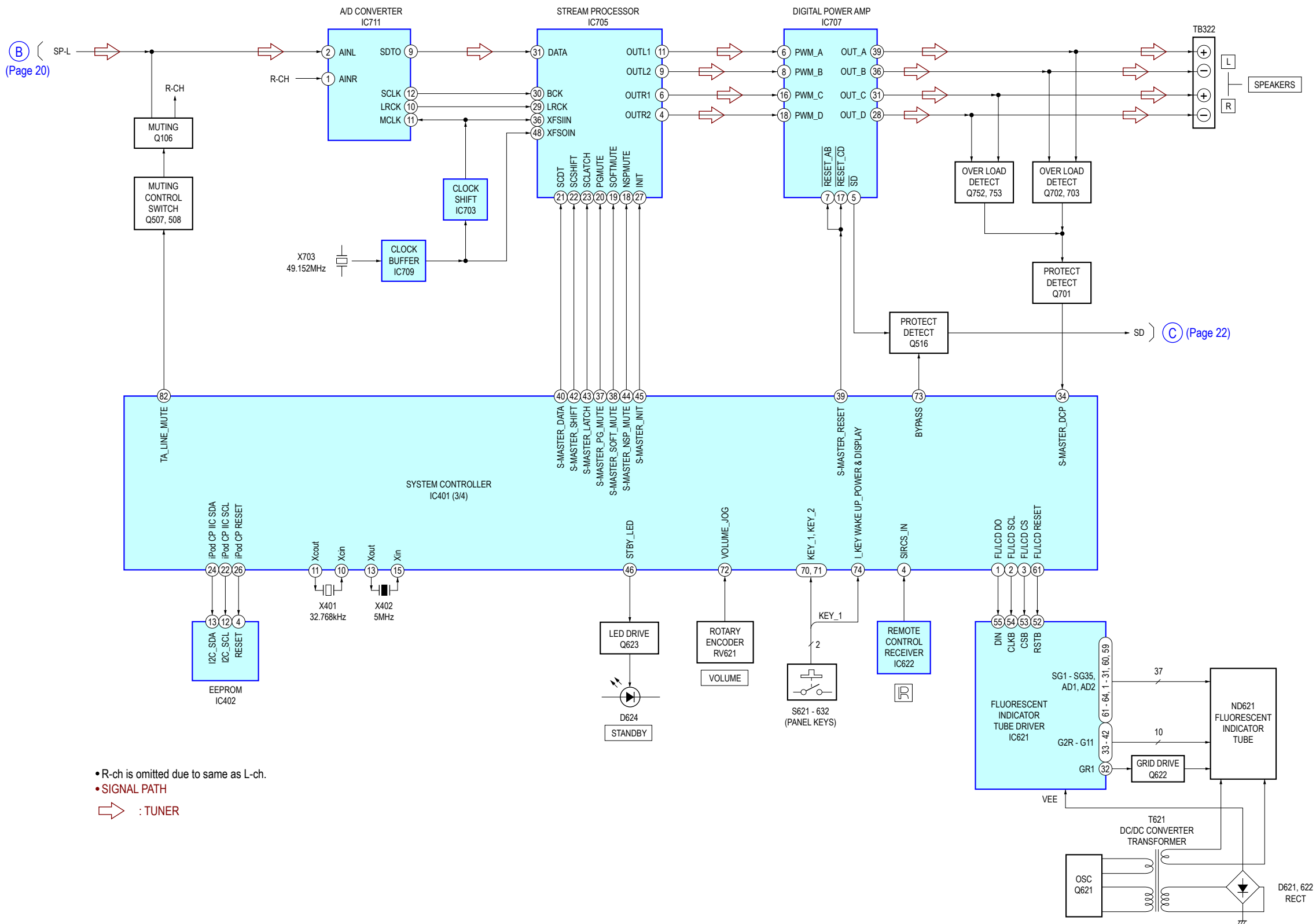

5-4. BLOCK DIAGRAM - POWER SUPPLY Section -

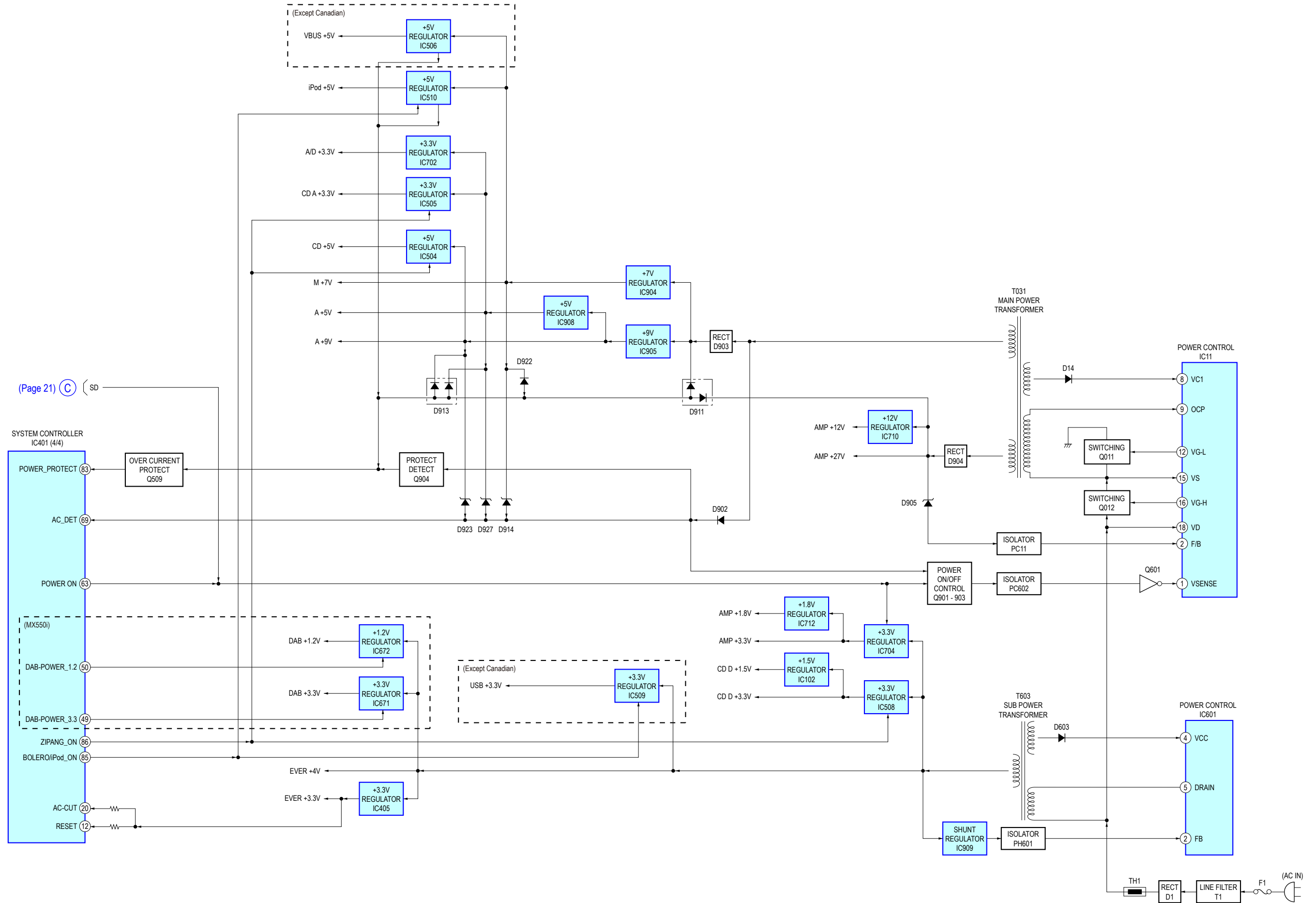

THIS NOTE IS COMMON FOR PRINTED WIRING BOARDS AND SCHEMATIC DIAGRAMS.
(In addition to this, the necessary note is printed in each block.)

For Printed Wiring Boards.

Note:

- : Parts extracted from the component side.
- : Parts extracted from the conductor side.
- △: Internal component.
- : Pattern from the side which enables seeing. (The other layers' patterns are not indicated.)

Caution:

Pattern face side: Parts on the pattern face side seen from the pattern face are indicated.
 Conductor Side) from the pattern face are indicated.
 Parts face side: Parts on the parts face side seen from the parts face are indicated.
 (Component Side)

Caution:

Pattern face side: Parts on the pattern face side seen from the pattern face are indicated.
 (SIDE B)
 Parts face side: Parts on the parts face side seen from the parts face are indicated.
 (SIDE A)

- Indication of transistor.

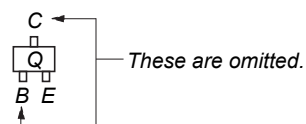

- Abbreviation

CH : Chinese model
 CND : Canadian model
 SP : Singapore model

For Schematic Diagrams.

Note:

- All capacitors are in μF unless otherwise noted. (p: pF) 50 WV or less are not indicated except for electrolytics and tantalums.
- All resistors are in Ω and 1/4 W or less unless otherwise specified.
- △: Internal component.
- : Nonflammable resistor.
- : Panel designation.

Note: The components identified by mark △ or dotted line with mark △ are critical for safety. Replace only with part number specified.

Note: Les composants identifiés par une marque △ sont critiques pour la sécurité. Ne les remplacer que par une pièce portant le numéro spécifié.

注意: 原理图和零件清单中标有△记号的零部件, 或带有△记号的虚线所圈示的零部件, 对于维系安全至关重要。因此只能以指定号码的零部件来更换。

- : B+ Line.
- : B- Line.
- Voltages and waveforms are dc with respect to ground under no-signal (detuned) conditions.
- BD96/BD96U Board –
 no mark: CD PLAY
- Other Boards –
 no mark: TUNER FM
 < >: TUNER DAB
 * : Impossible to measure
- Voltages are taken with VOM (Input impedance 10 M Ω). Voltage variations may be noted due to normal production tolerances.
- Waveforms are taken with a oscilloscope. Voltage variations may be noted due to normal production tolerances.
- Circled numbers refer to waveforms.
- Signal path.
 : TUNER
 : CD PLAY
 : USB
 : iPod/iPhone
 : AUDIO IN
- Abbreviation
 CH : Chinese model
 CND : Canadian model
 SP : Singapore model

• Circuit Boards Location.

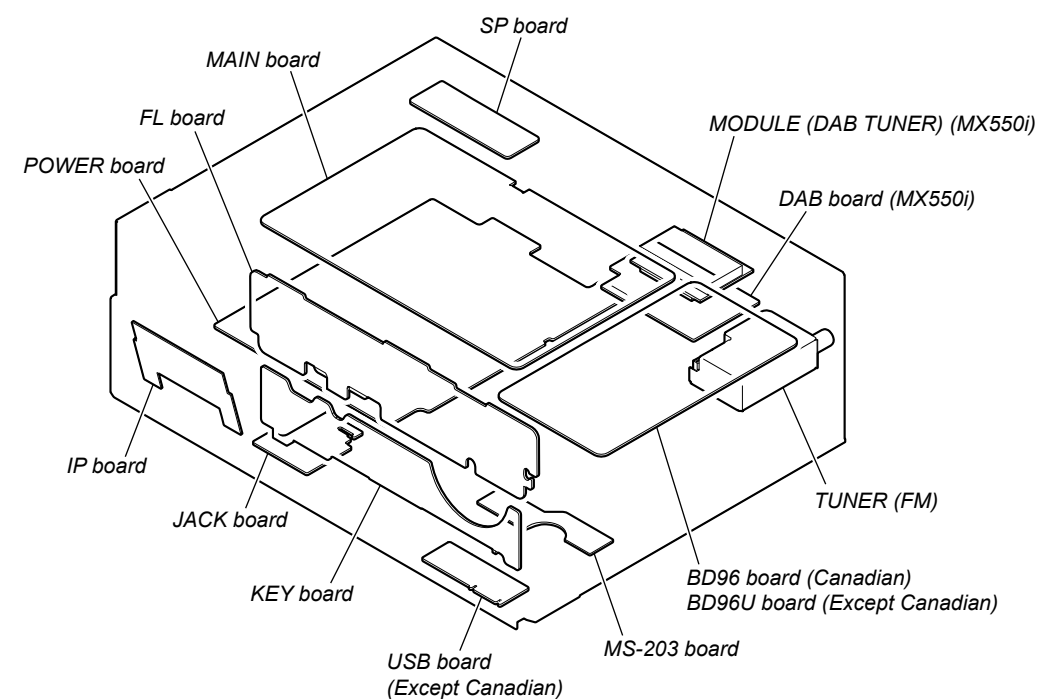

5-5. PRINTED WIRING BOARD - BD96/BD96U Board (Side A) - • See page 23 for Circuit Boards Location. •  : Uses unleaded solder.

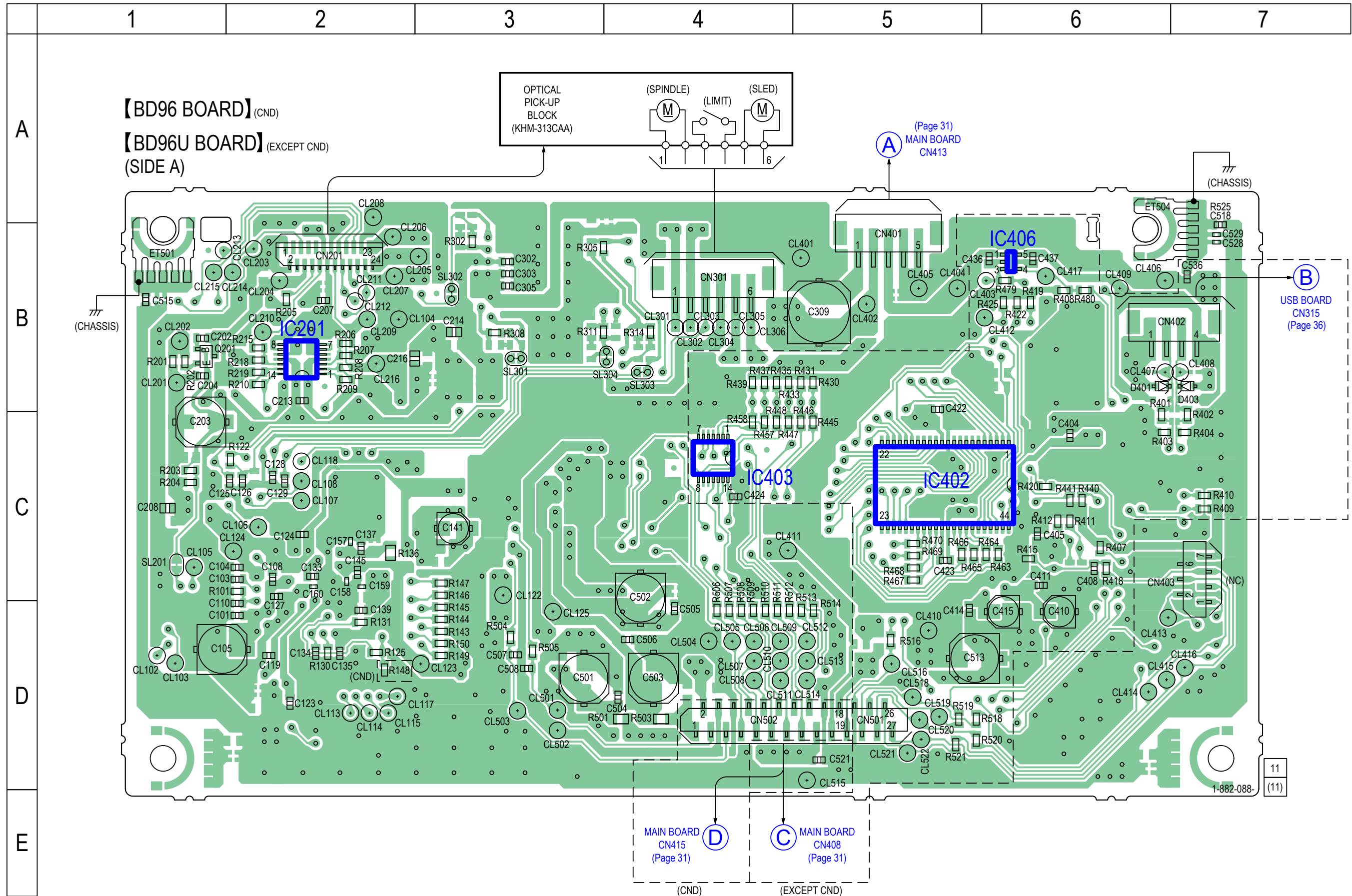

5-6. PRINTED WIRING BOARD - BD96/BD96U Board (Side B) - • See page 23 for Circuit Boards Location. •  : Uses unleaded solder.

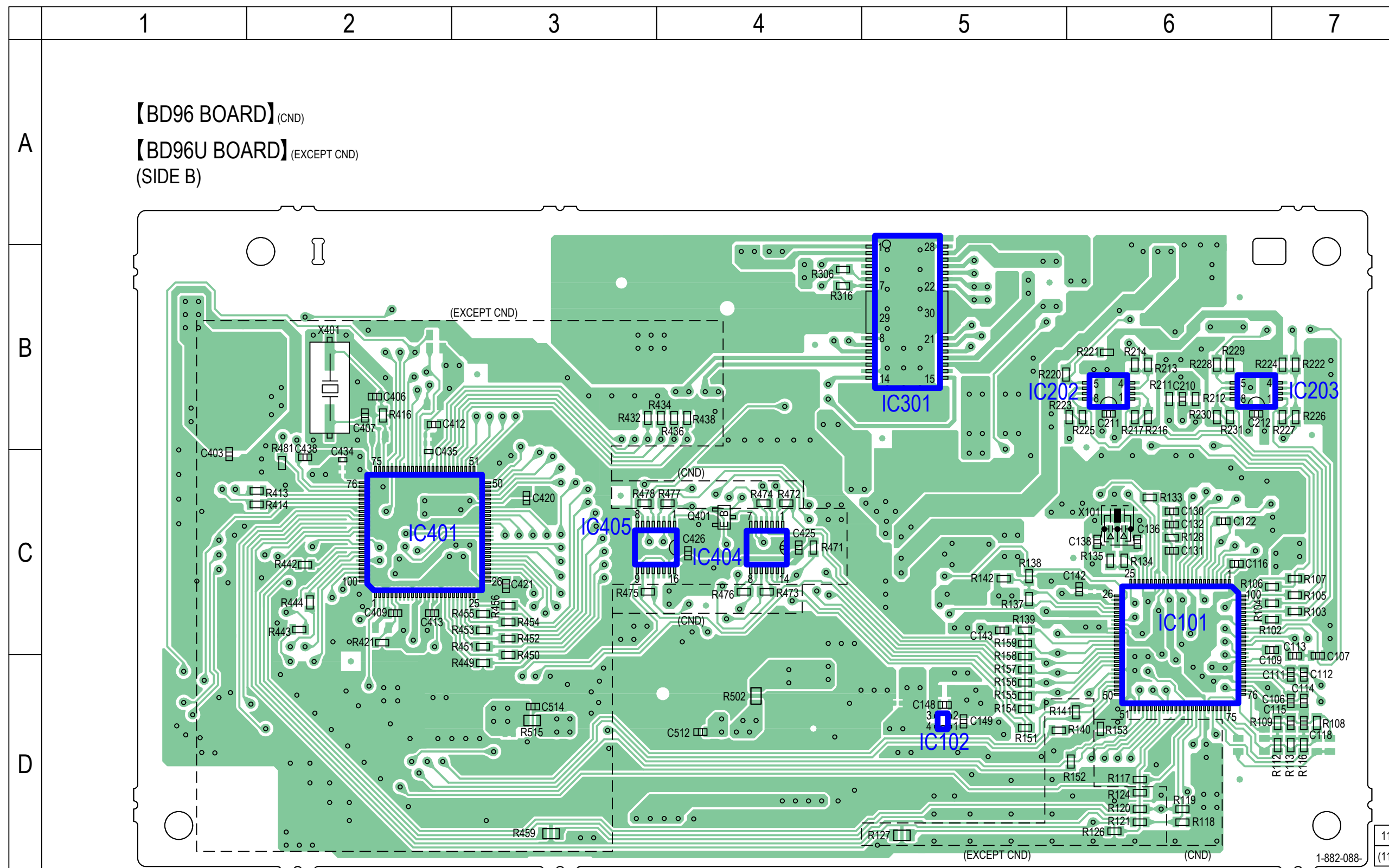

5-7. SCHEMATIC DIAGRAM - BD96/BD96U Board (1/2) - • See page 28 for Waveforms. • See page 42 for IC Block Diagrams. • See page 47 for IC Pin Function Description.

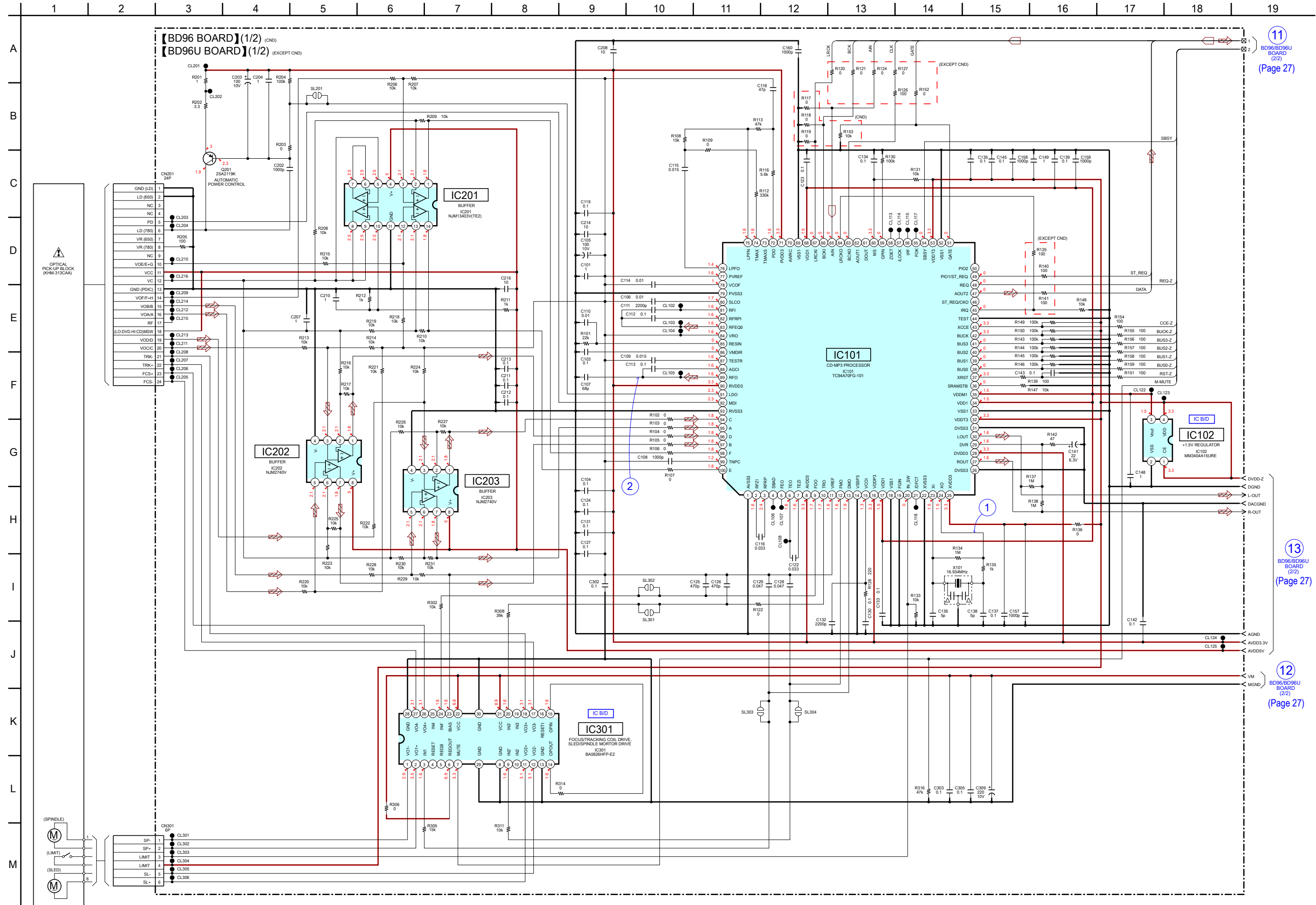

11
BD96/BD96U
BOARD
(2/2)
(Page 27)

13
BD96/BD96U
BOARD
(2/2)
(Page 27)

12
BD96/BD96U
BOARD
(2/2)
(Page 27)

5-8. SCHEMATIC DIAGRAM - BD96/BD96U Board (2/2) - • See page 28 for Waveforms. • See page 42 for IC Block Diagrams. • See page 47 for IC Pin Function Description.

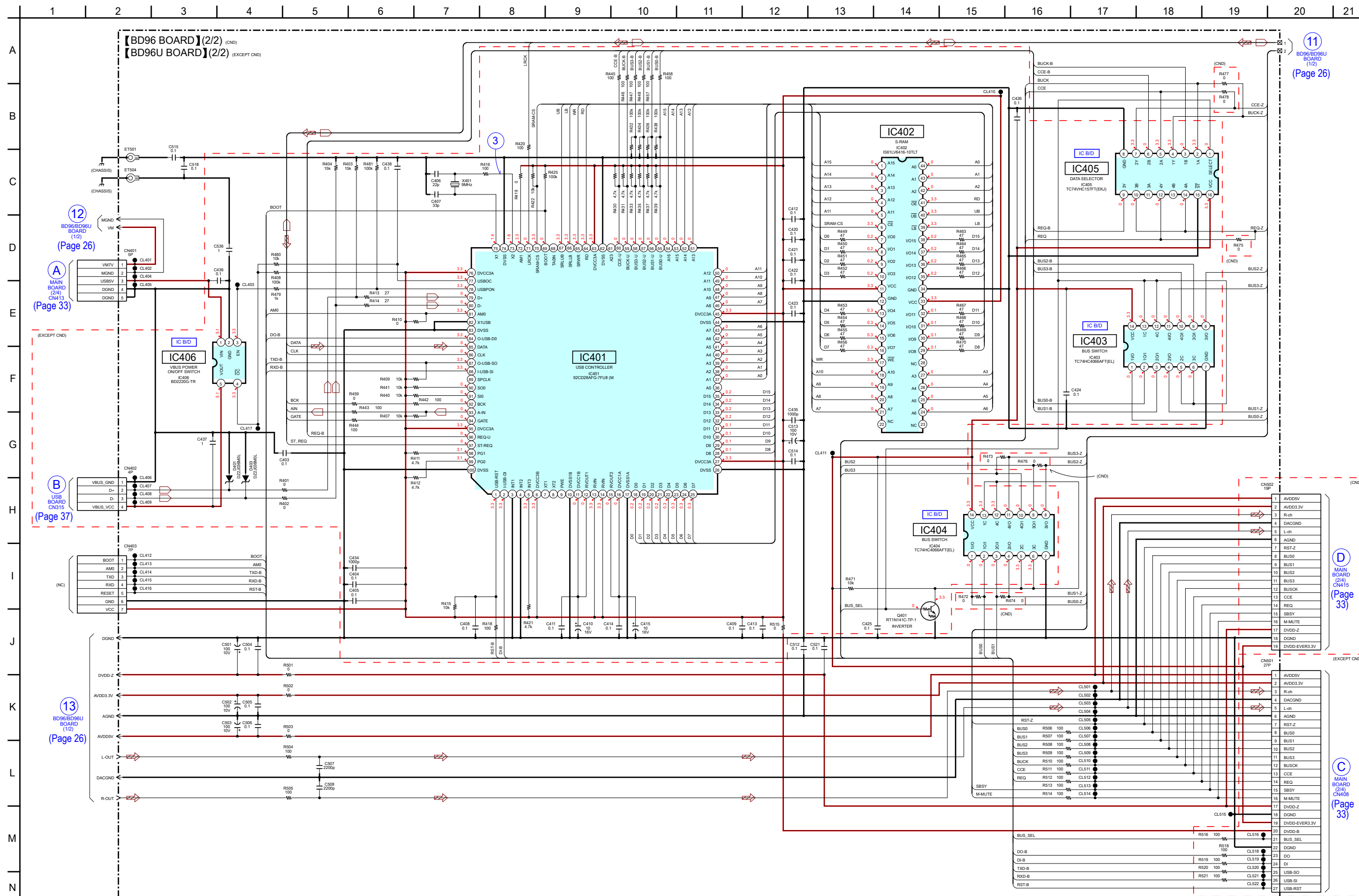

• Waveforms

– BD96/BD96U Board –

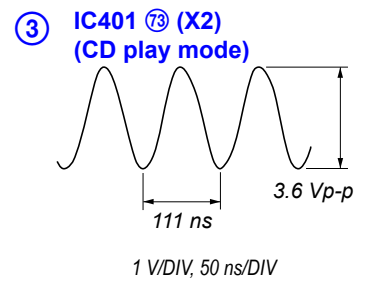
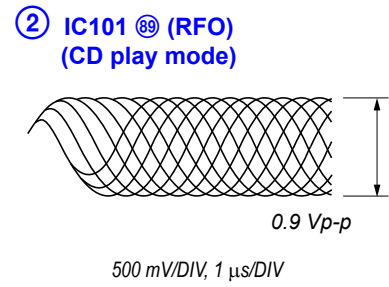
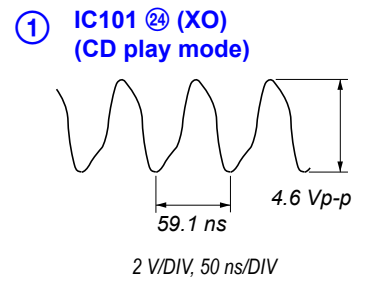

– MAIN Board –

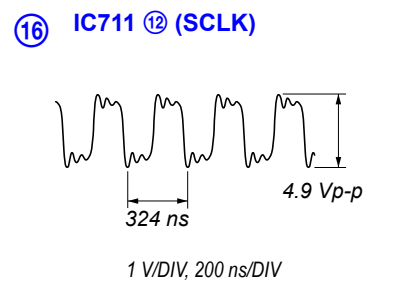
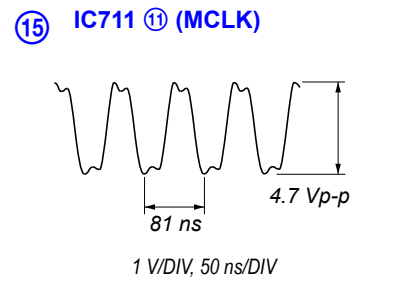
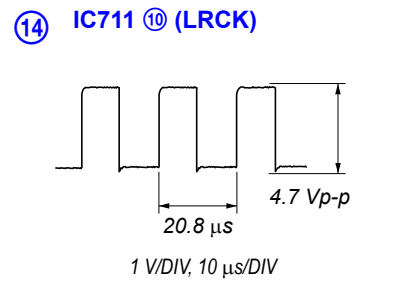
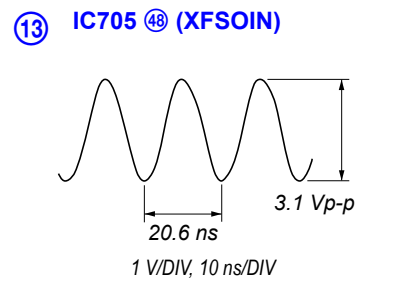
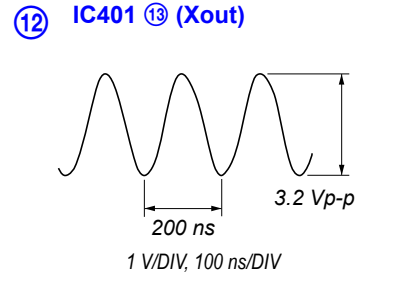
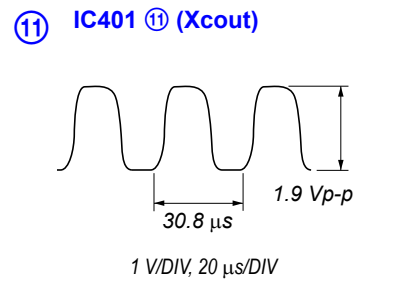

5-9. PRINTED WIRING BOARD - DAB Board (MX550i) -

• See page 23 for Circuit Boards Location. • : Uses unleaded solder.

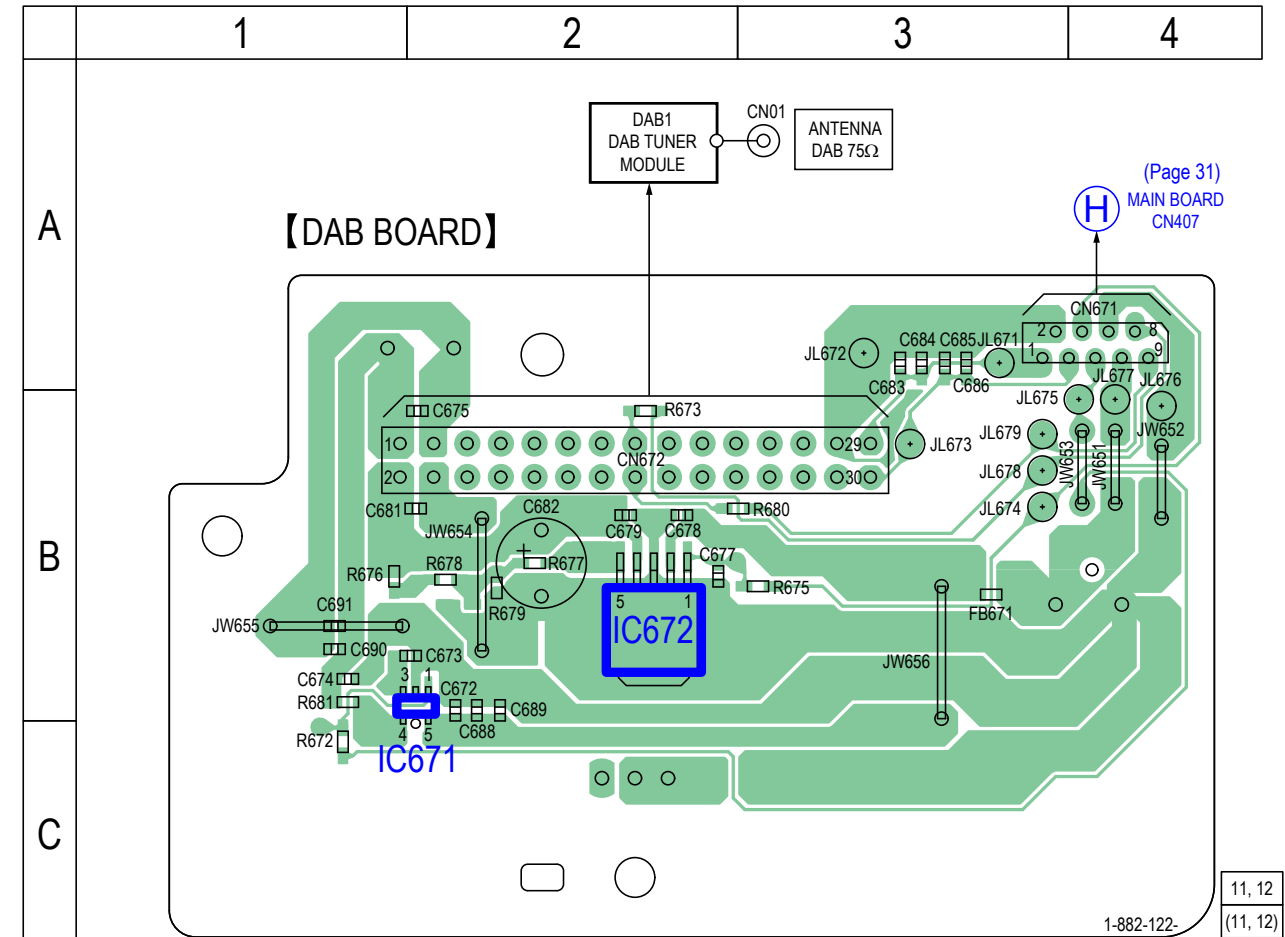

5-10. SCHEMATIC DIAGRAM - DAB Board (MX550i) - • See page 42 for IC Block Diagrams.

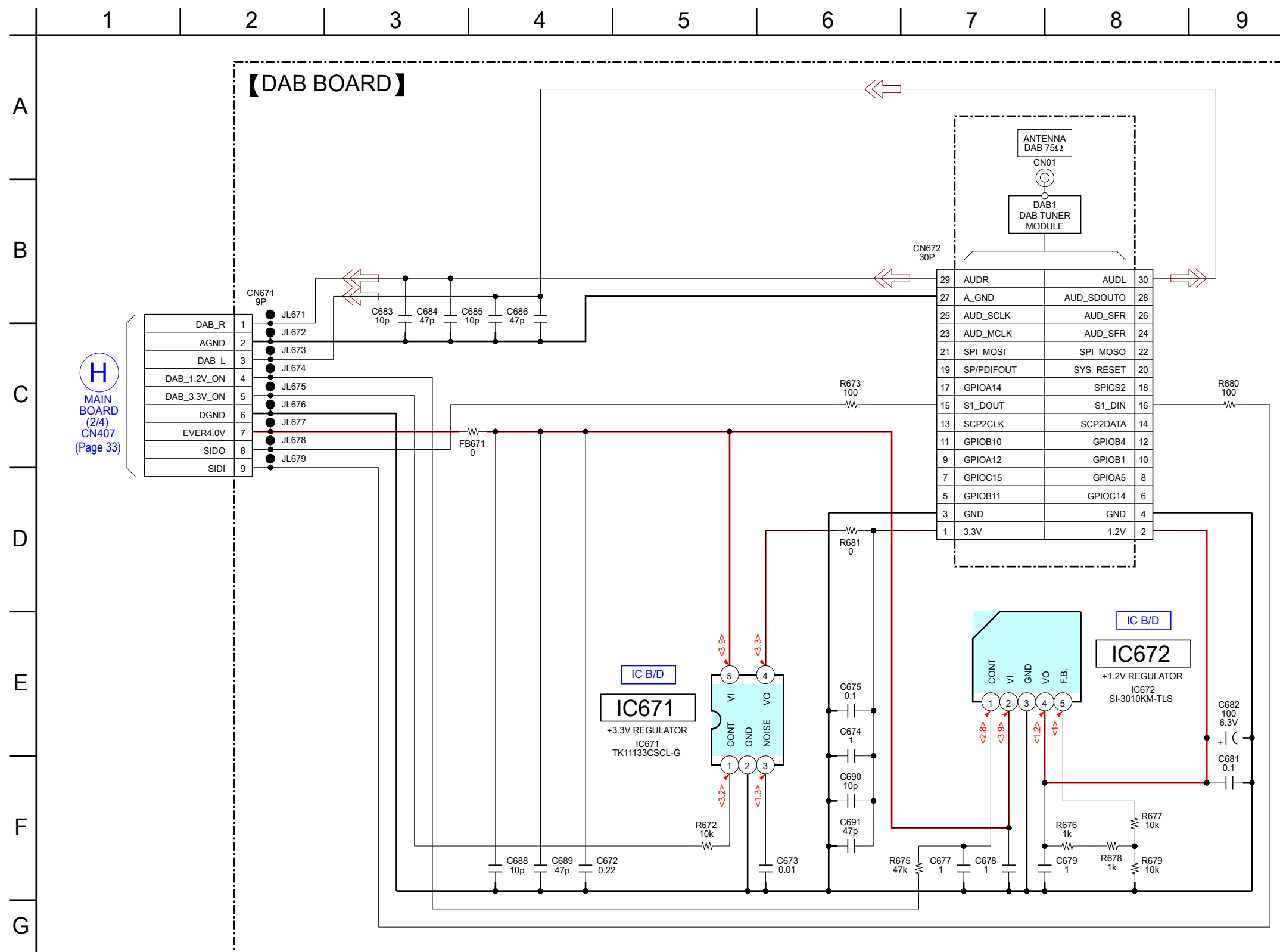

5-11. PRINTED WIRING BOARD - MAIN Section (1/2) - • See page 23 for Circuit Boards Location. •  : Uses unleaded solder.

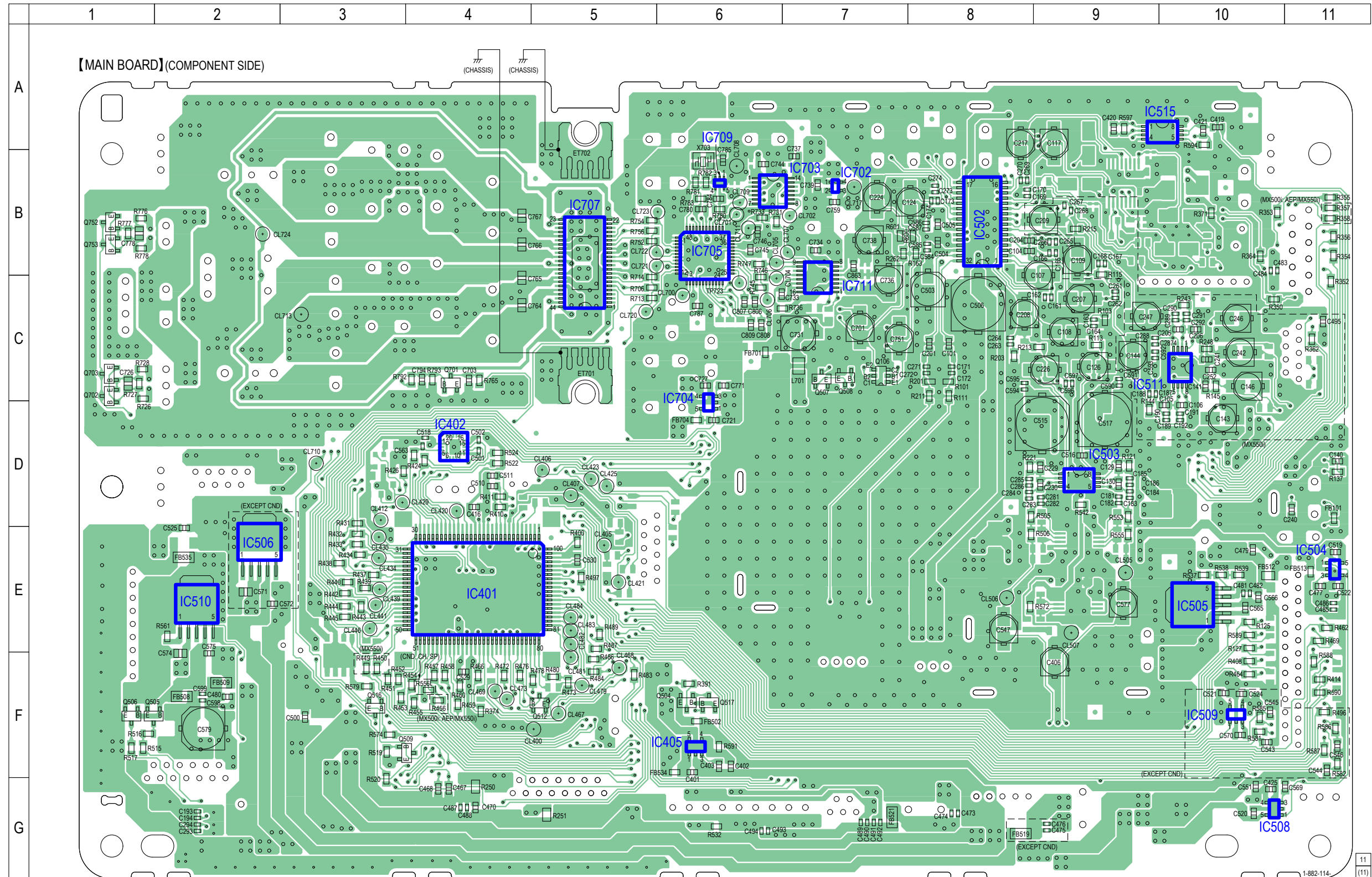

5-12. PRINTED WIRING BOARDS - MAIN Section (2/2) - • See page 23 for Circuit Boards Location. •  : Uses unleaded solder.

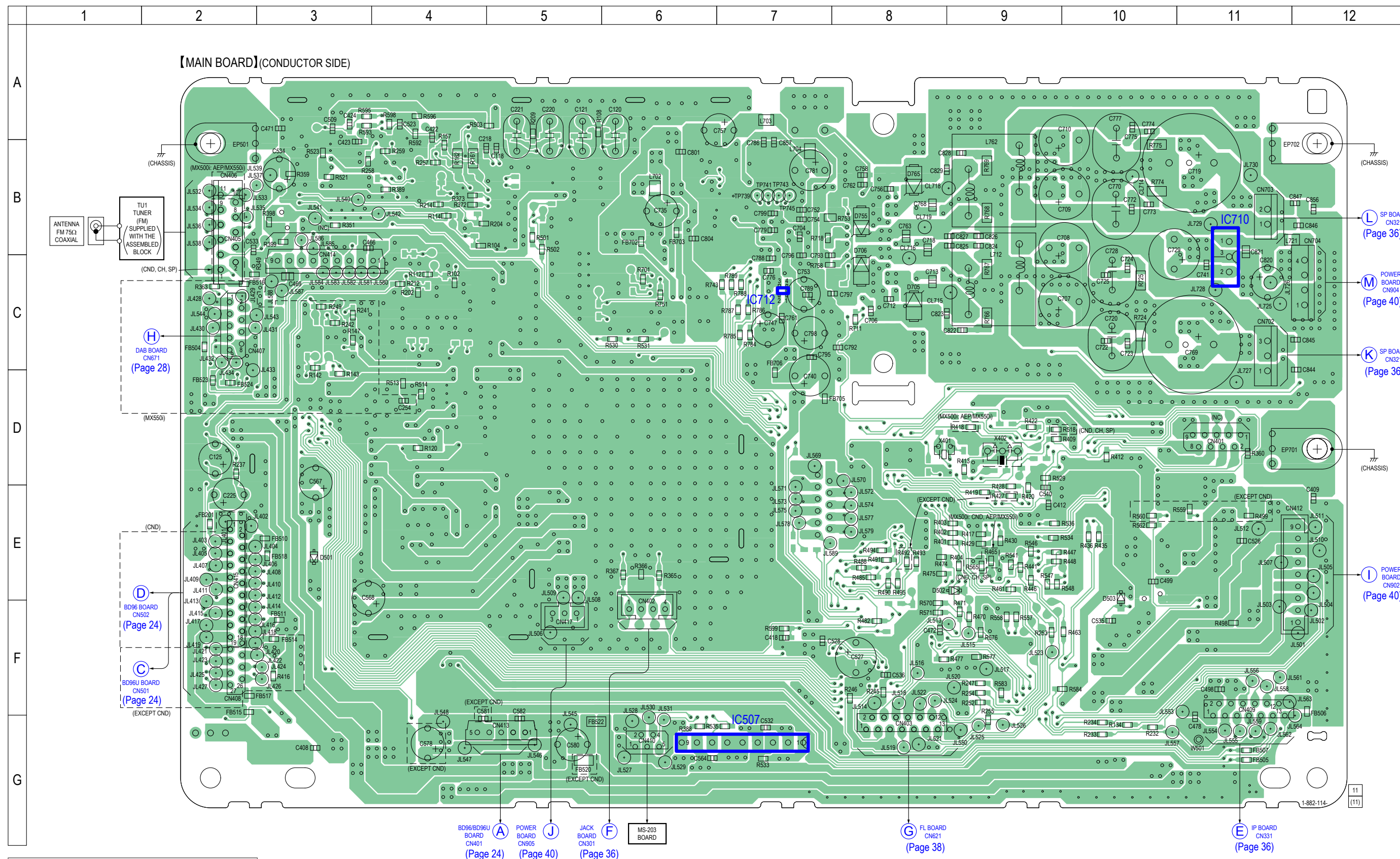

Note: When the MS-203 board is damaged, exchange the entire CDM85 (CD) ASSY.

5-13. SCHEMATIC DIAGRAM - MAIN Section (1/4) - • See page 28 for Waveforms. • See page 42 for IC Block Diagrams. • See page 47 for IC Pin Function Description.

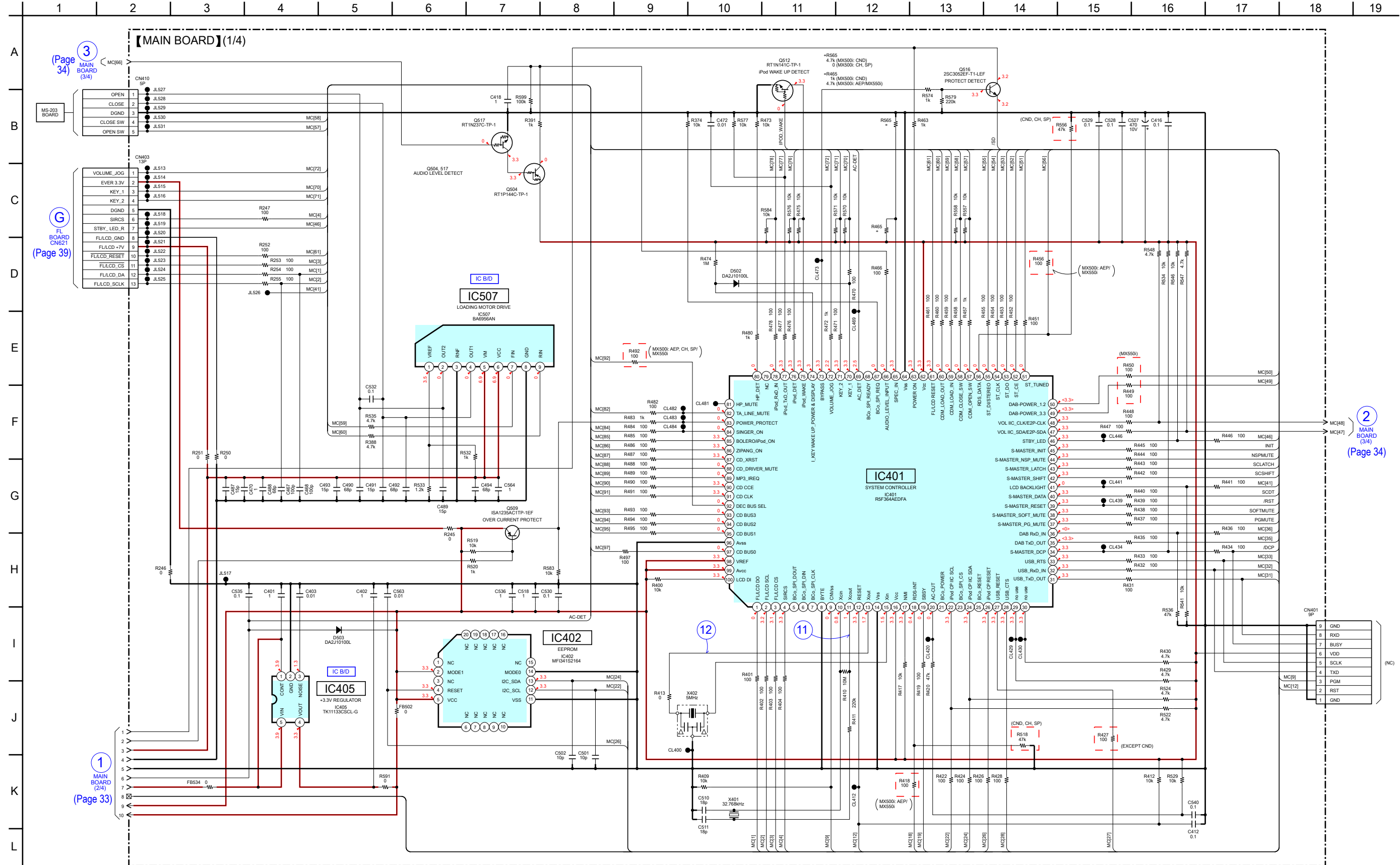

Note: When the MS-203 board is damaged, exchange the entire CDM85 (CD) ASSY.

5-14. SCHEMATIC DIAGRAM - MAIN Section (2/4) - • See page 42 for IC Block Diagrams.

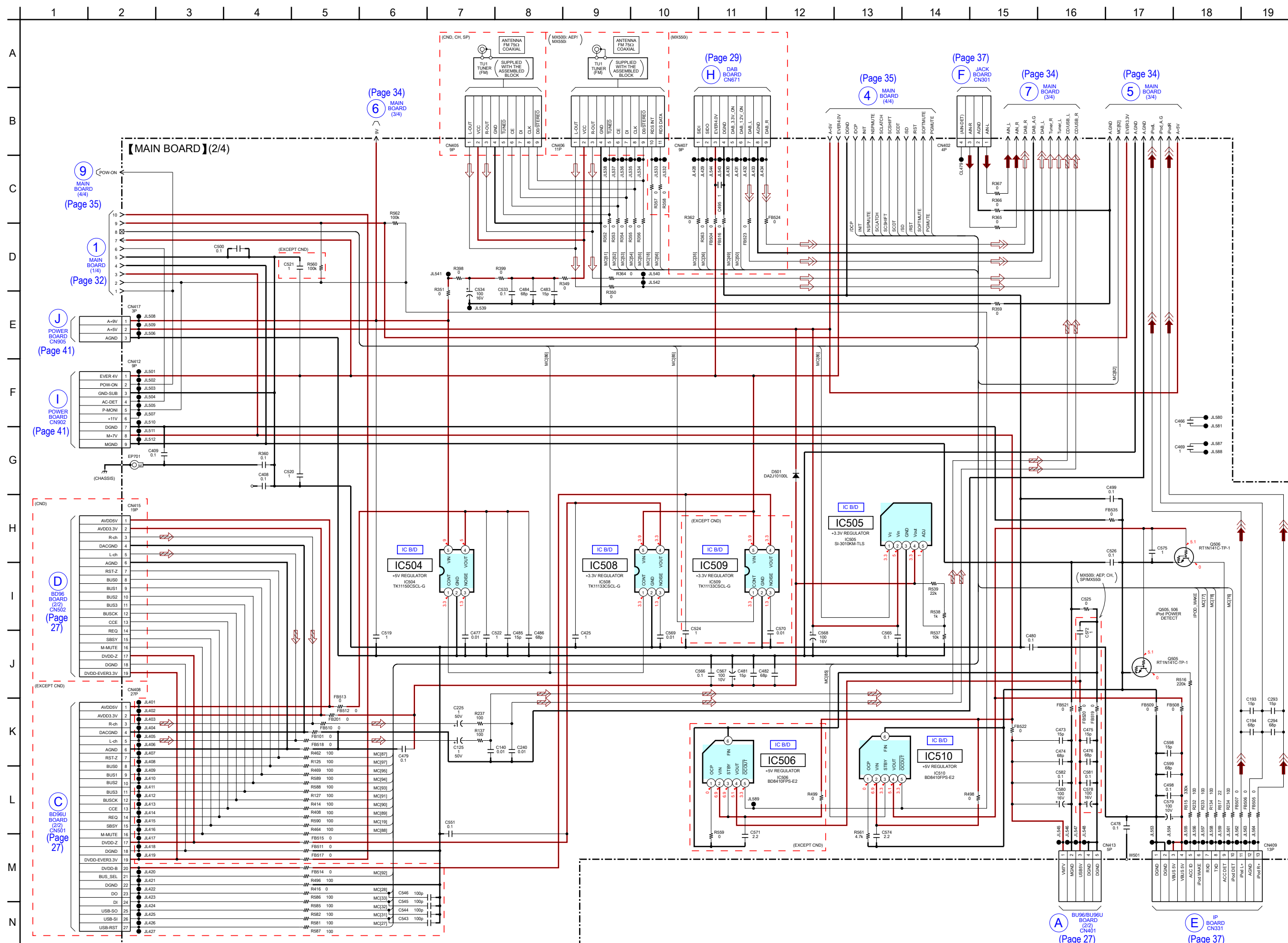

5-15. SCHEMATIC DIAGRAM - MAIN Section (3/4) - • See page 42 for IC Block Diagrams.

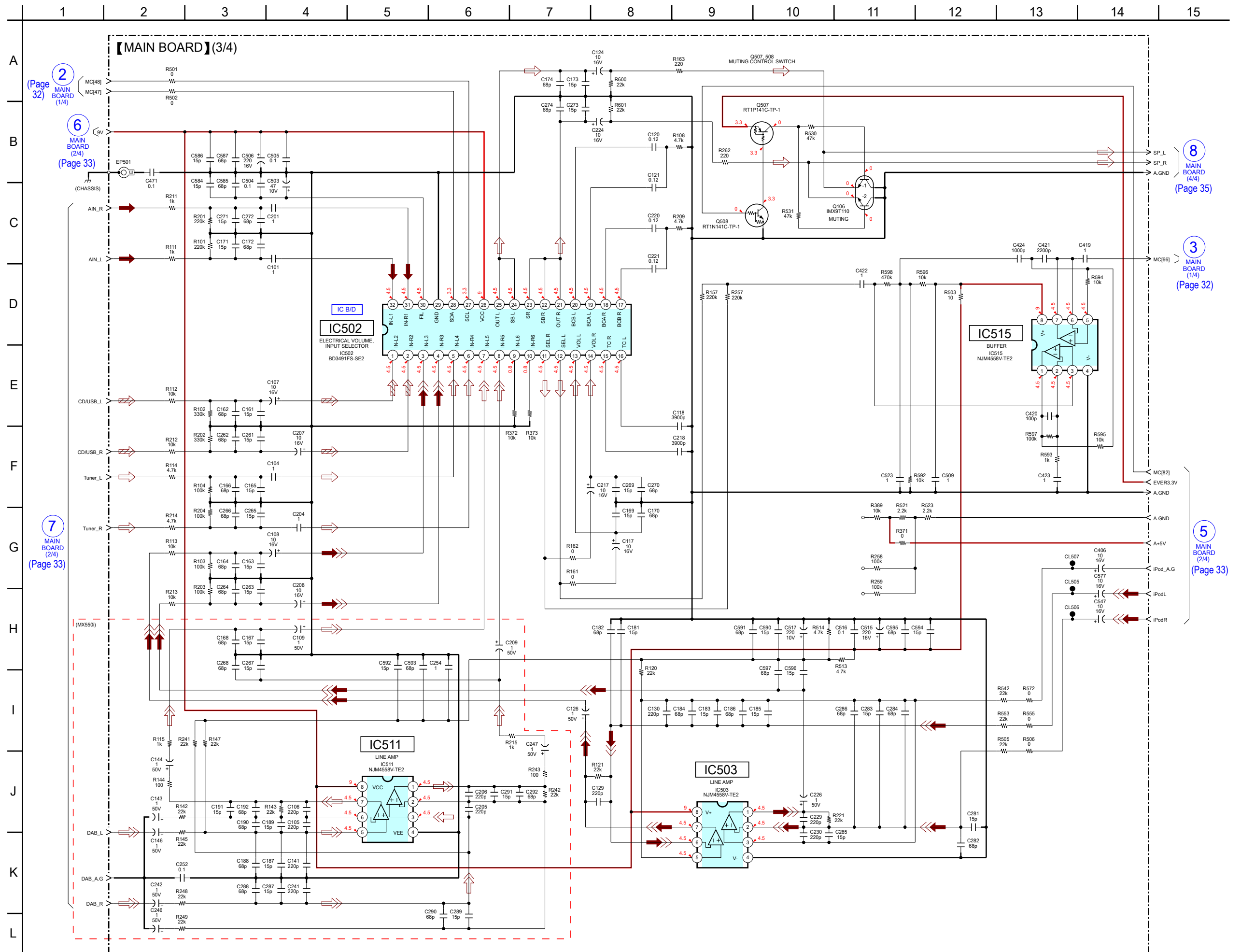

5-16. SCHEMATIC DIAGRAM - MAIN Section (4/4) - • See page 42 for IC Block Diagrams.

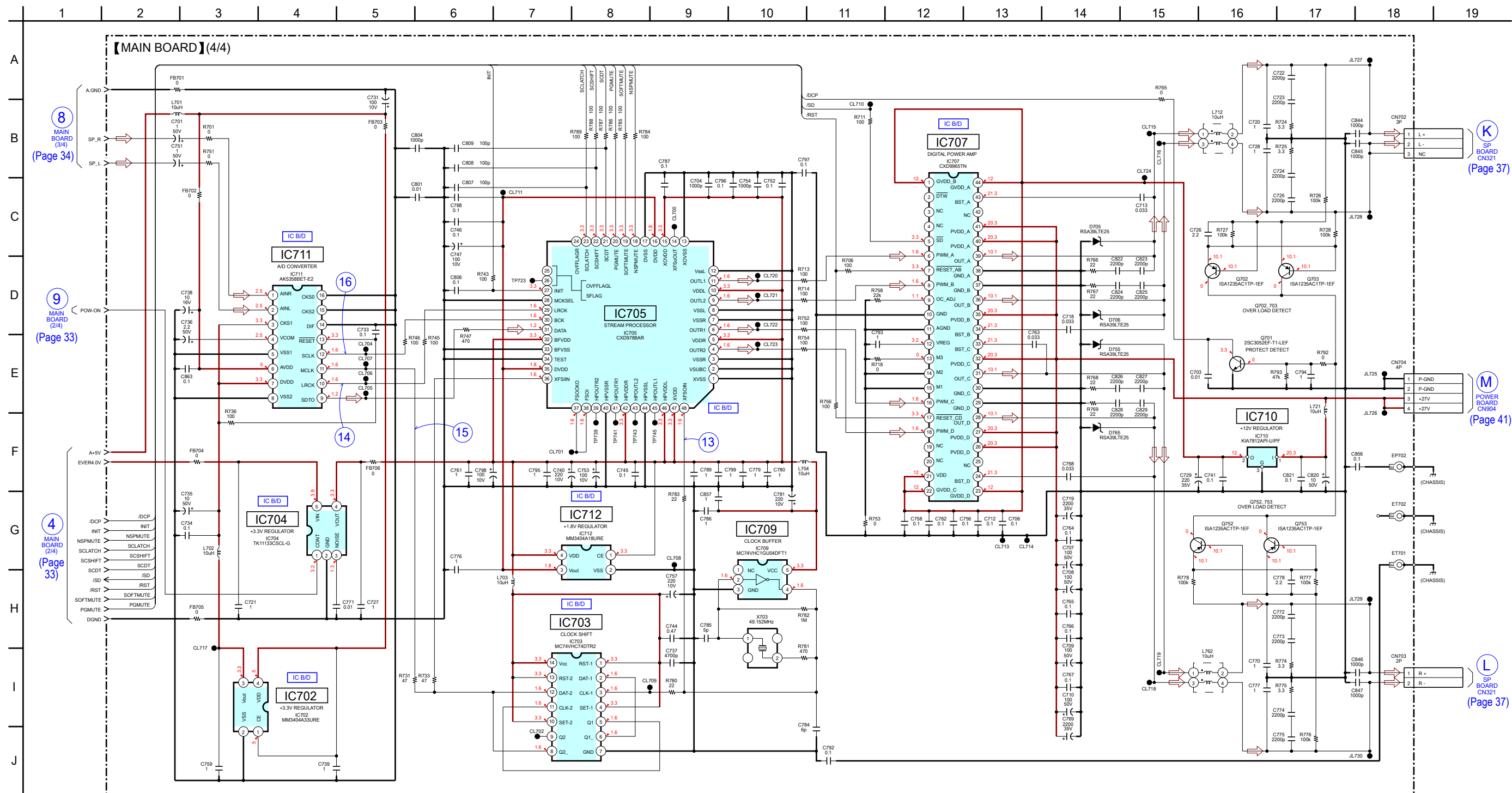

8 MAIN BOARD (3/4) (Page 34)

9 MAIN BOARD (2/4) (Page 33)

4 MAIN BOARD (2/4) (Page 33)

K SP BOARD CN321 (Page 37)

M POWER BOARD CN904 (Page 41)

L SP BOARD CN321 (Page 37)

5-17. PRINTED WIRING BOARDS - IP/JACK/SP/USB Boards - • See page 23 for Circuit Boards Location. •  : Uses unleaded solder.

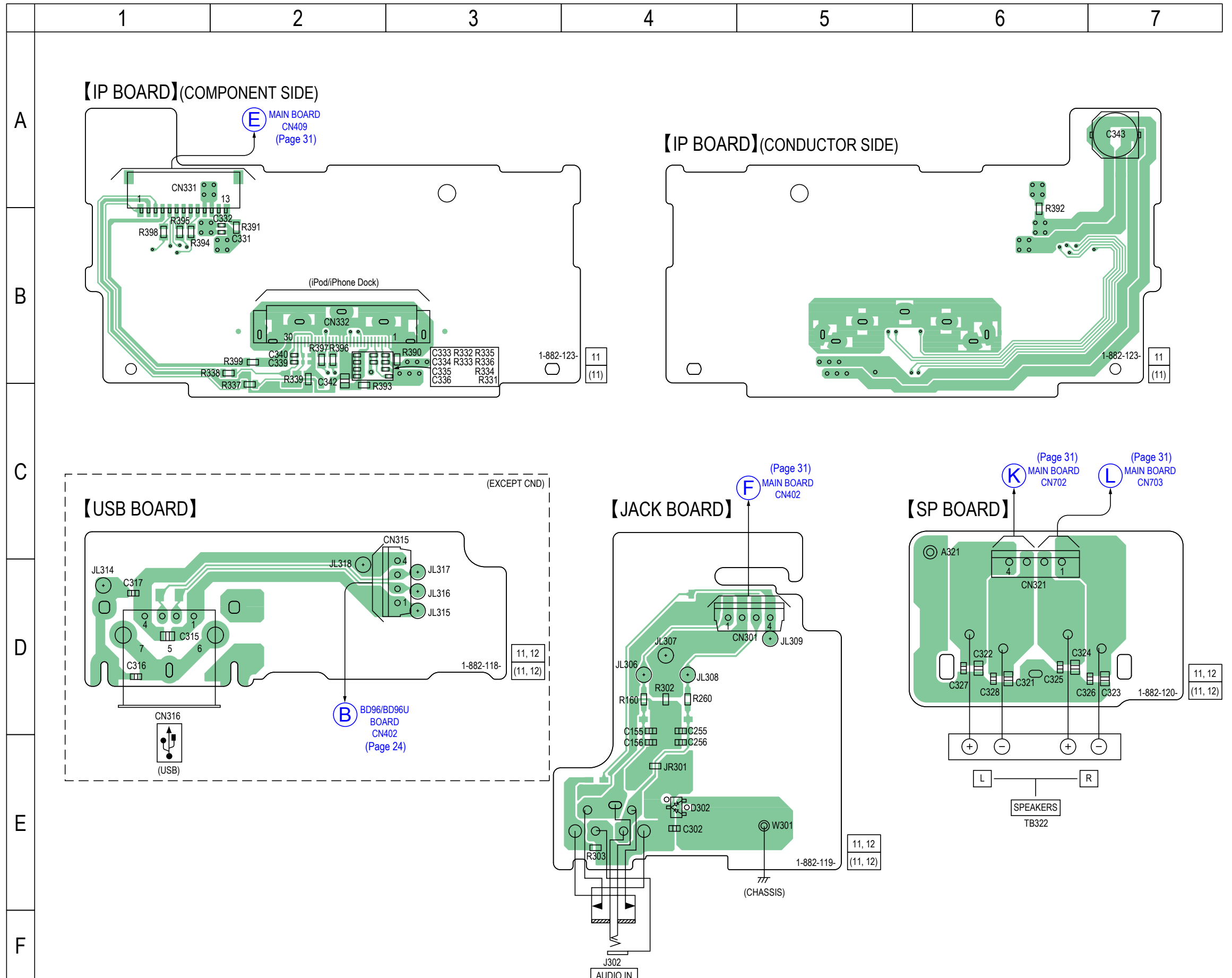

5-18. SCHEMATIC DIAGRAM - IP/JACK/SP/USB Boards -

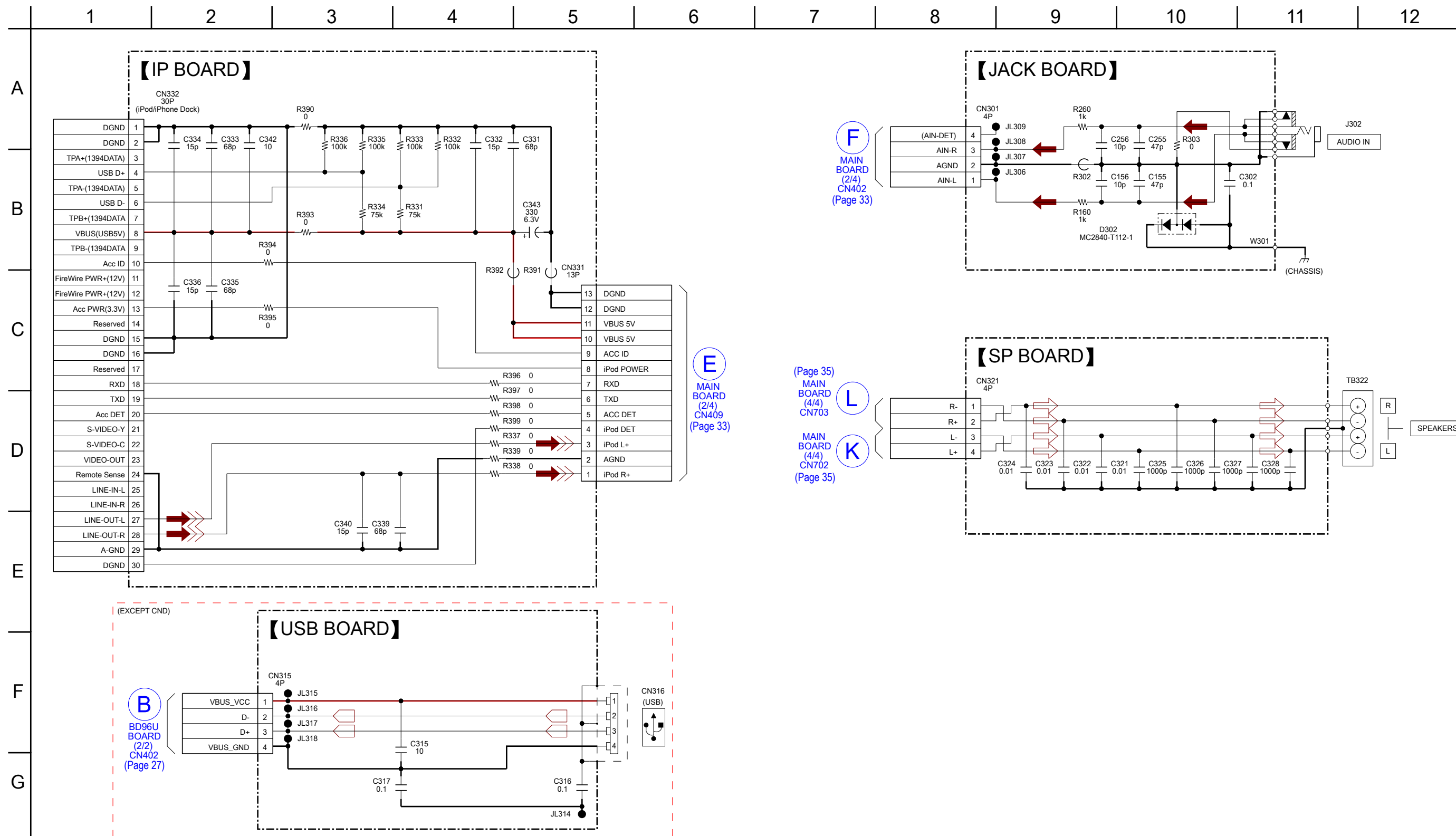

5-19. PRINTED WIRING BOARDS - PANEL Section - • See page 23 for Circuit Boards Location. •  : Uses unleaded solder.

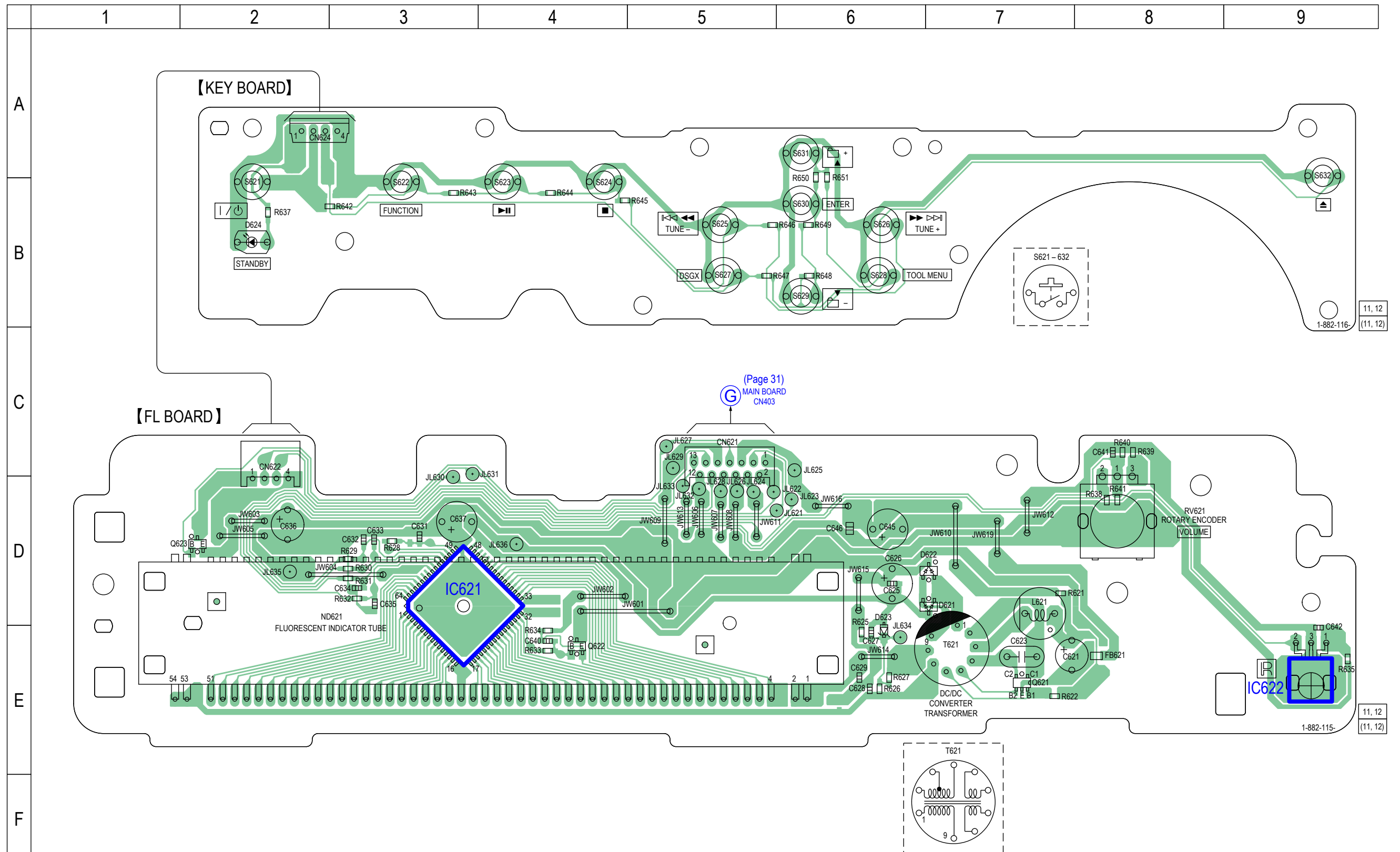

5-20. SCHEMATIC DIAGRAM - PANEL Section - • See page 42 for IC Block Diagrams.

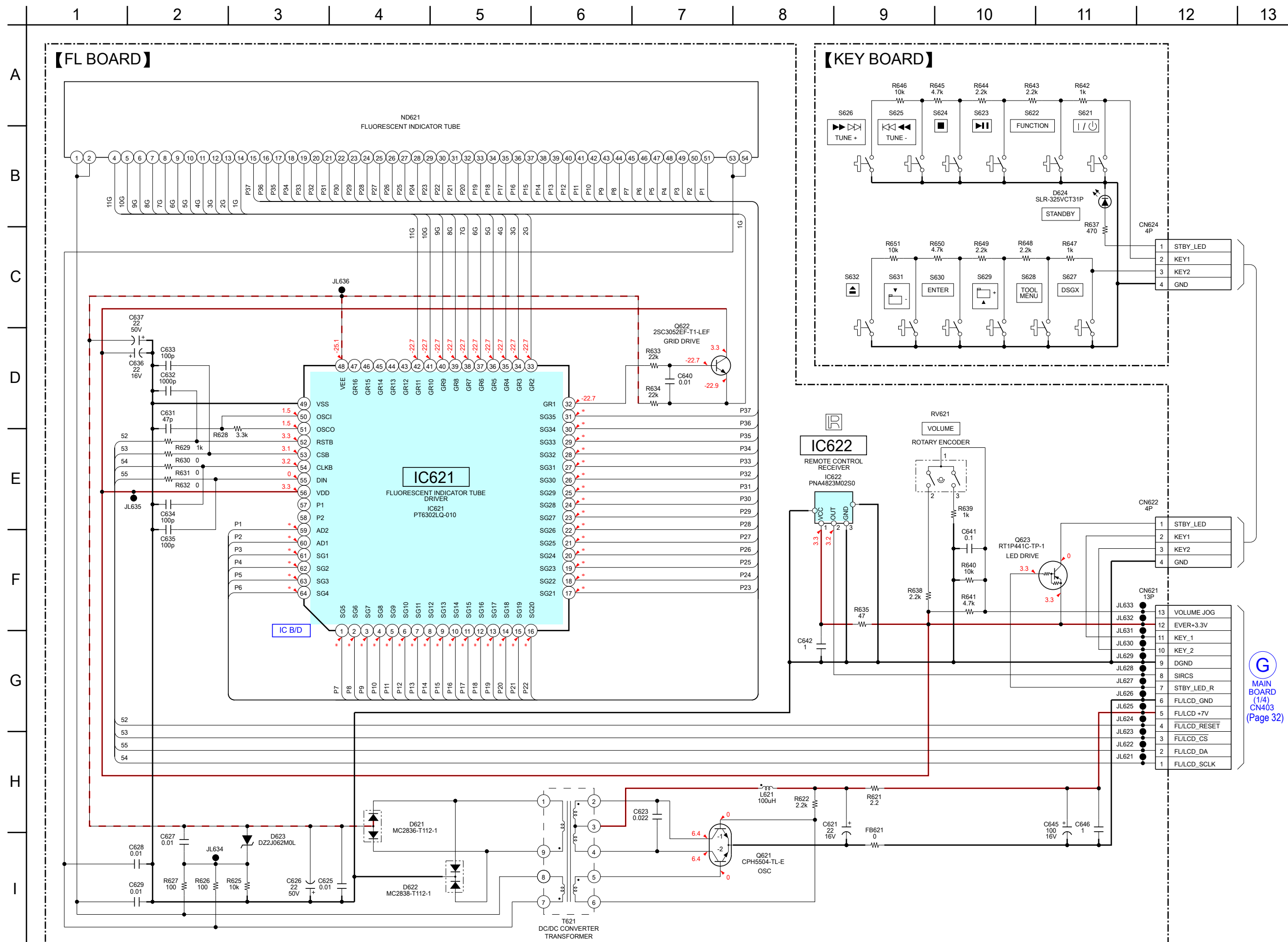

5-21. PRINTED WIRING BOARD - POWER Board - • See page 23 for Circuit Boards Location. •  : Uses unleaded solder.

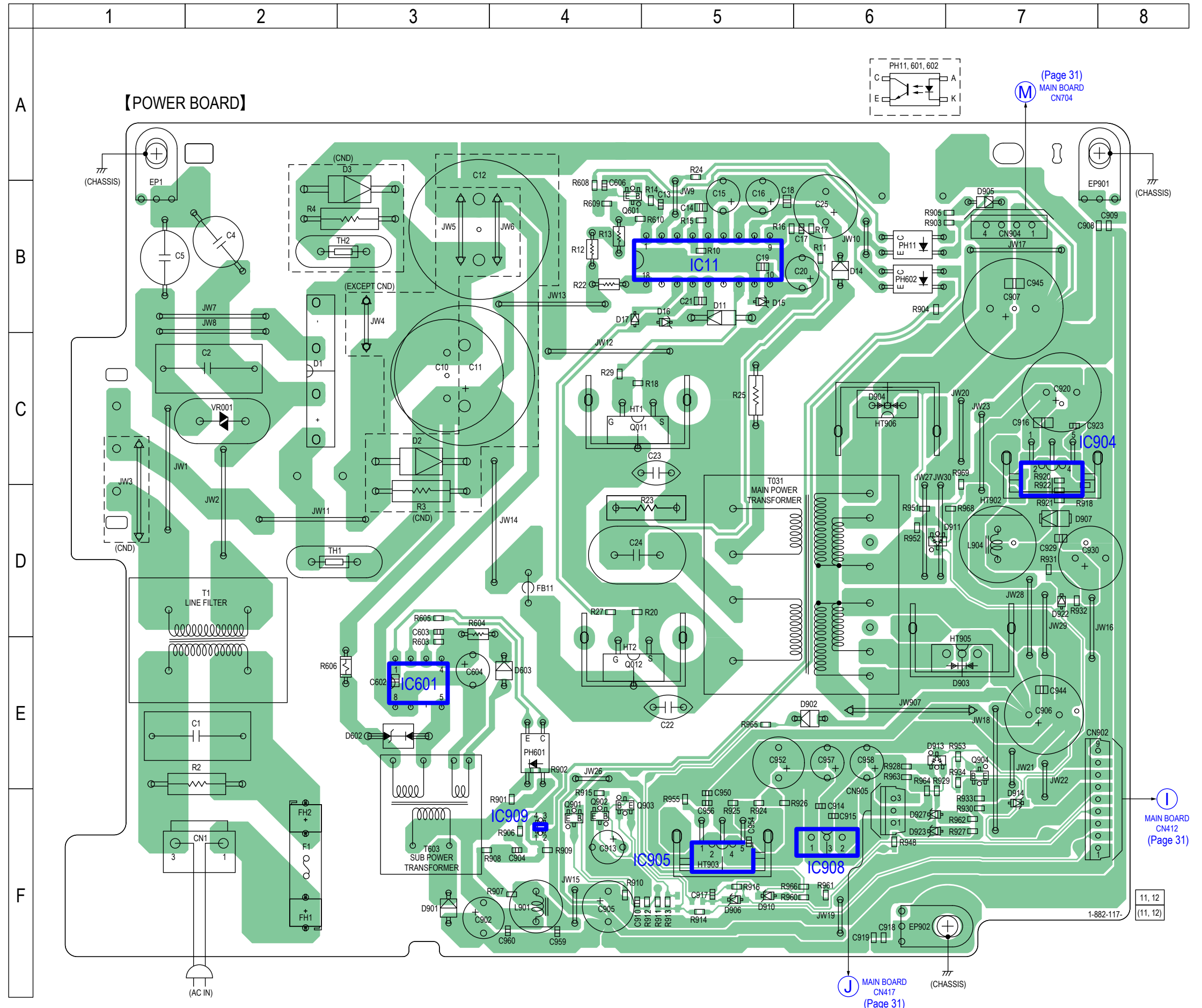

5-22. SCHEMATIC DIAGRAM - POWER Board - • See page 42 for IC Block Diagrams. • See page 47 for IC Pin Function Description.

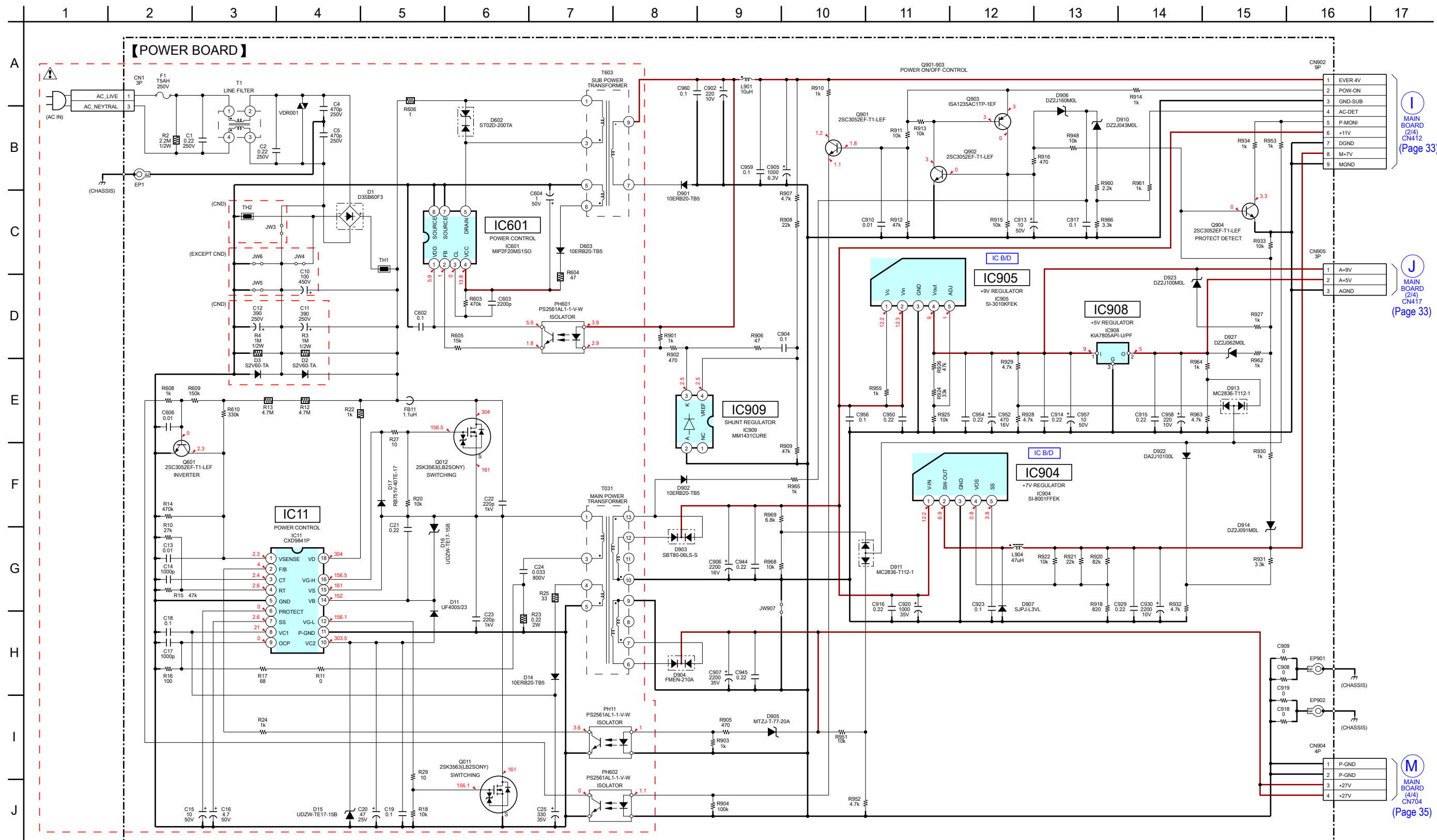

I
MAIN BOARD
(2/4)
CN412
(Page 33)

J
MAIN BOARD
(2/4)
CN417
(Page 33)

M
MAIN BOARD
(4/4)
CN704
(Page 33)

• IC Block Diagrams

– BD96/BD96U Board –
IC102 MM3404A15URE

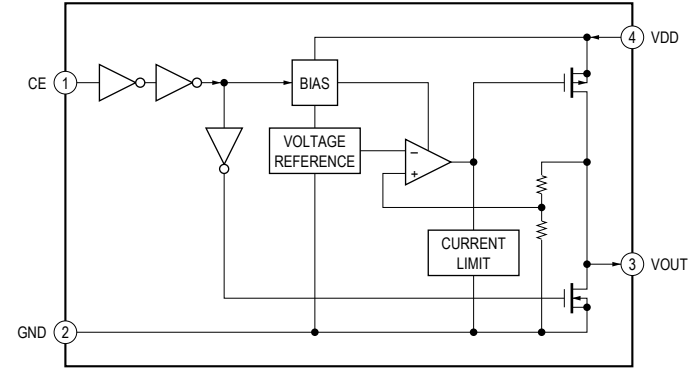

IC301 BA5826HFP-E2

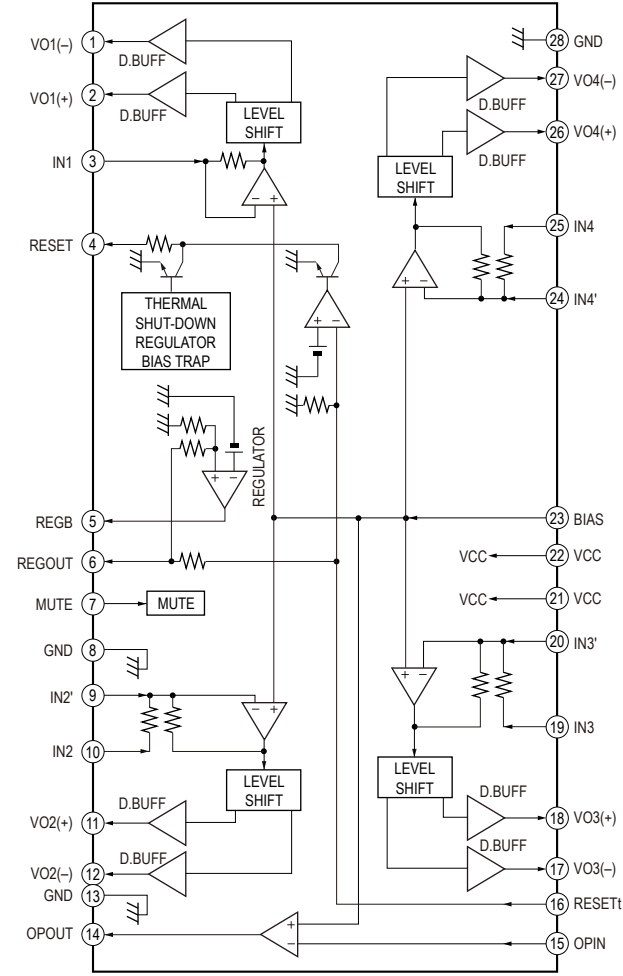

– DAB Board –
IC671 TK11133CSCL-G

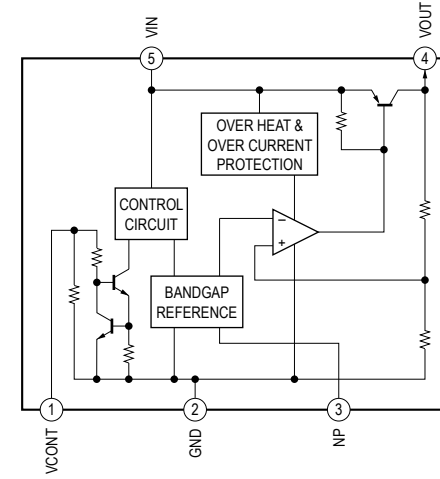

IC672 SI-3010KM-TLS

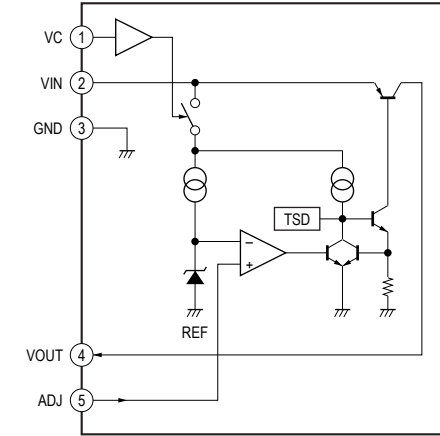

IC403, 404 TC74HC4066AFT (EL)

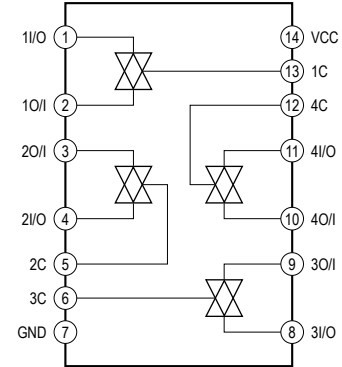

– MAIN Board –
IC405, 508, 509, 704 TK11133CSCL-G
IC504 TK11150CSCL-G

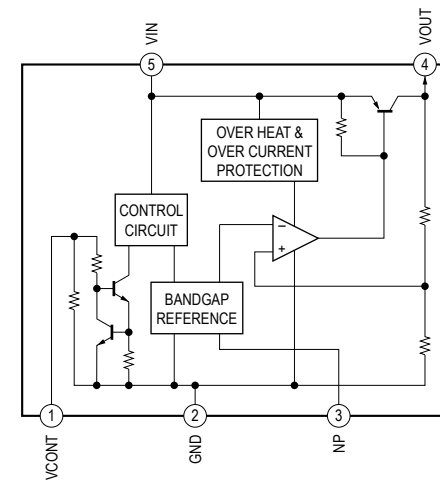

IC502 BD3491FS-SE2

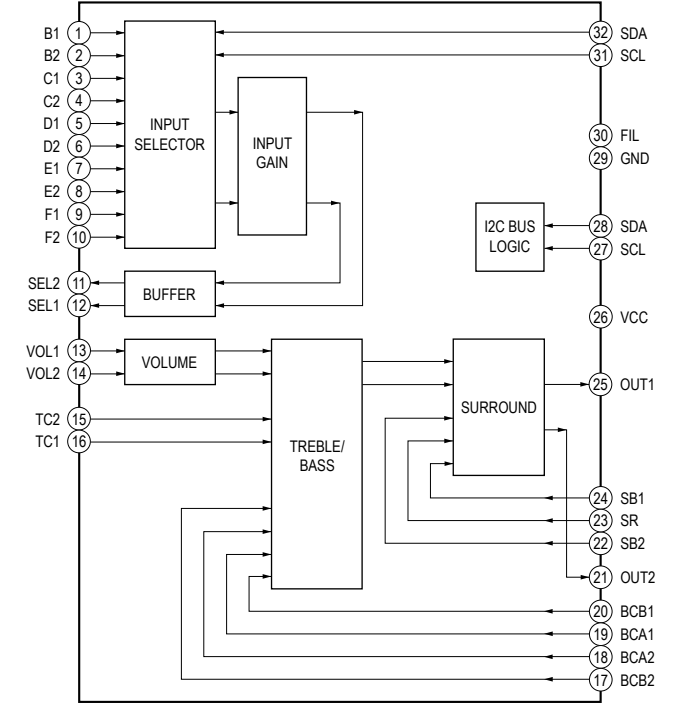

IC405 TC74VHC157FT (EKJ)

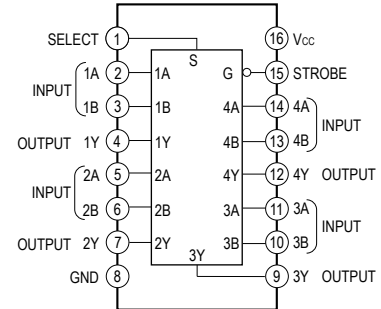

IC406 BD2220G-TR

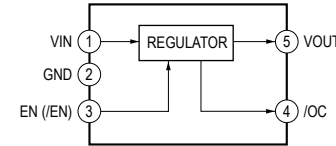

IC505 SI-3010KM-TLS

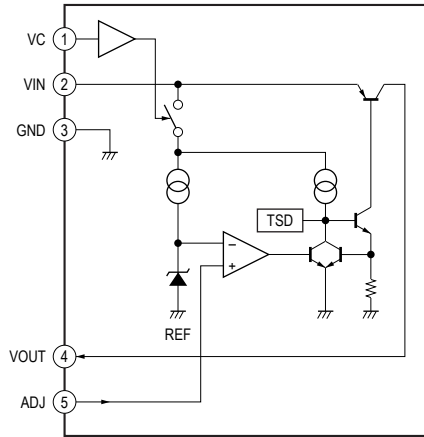

IC506, 510 BD8410FPS-E2

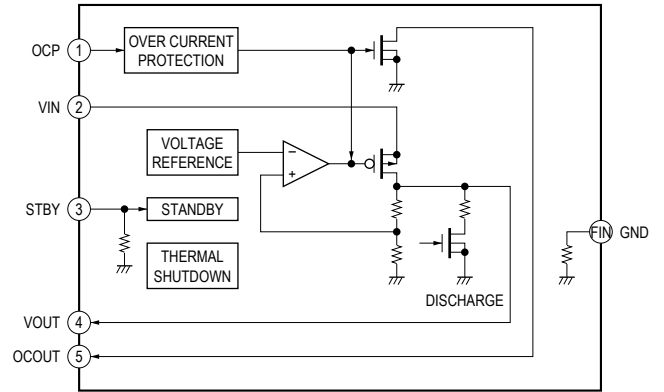

IC507 BA6956AN

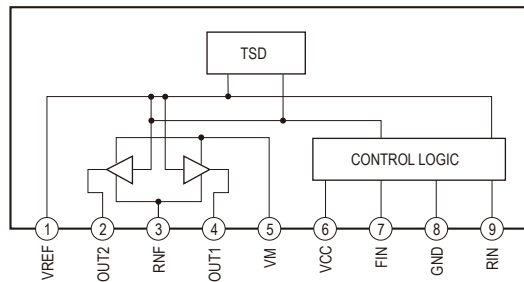

**IC702 MM3404A33URE
IC712 MM3404A18URE**

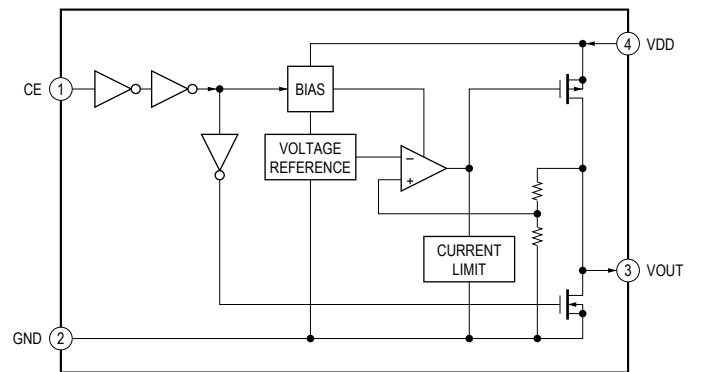

IC703 MC74VHC74DTR2

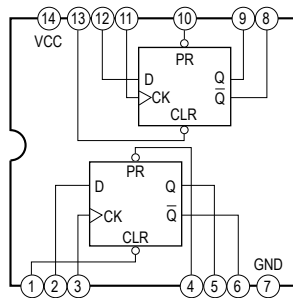

HCD-MX500i/MX550i

IC705 CXD9788AR

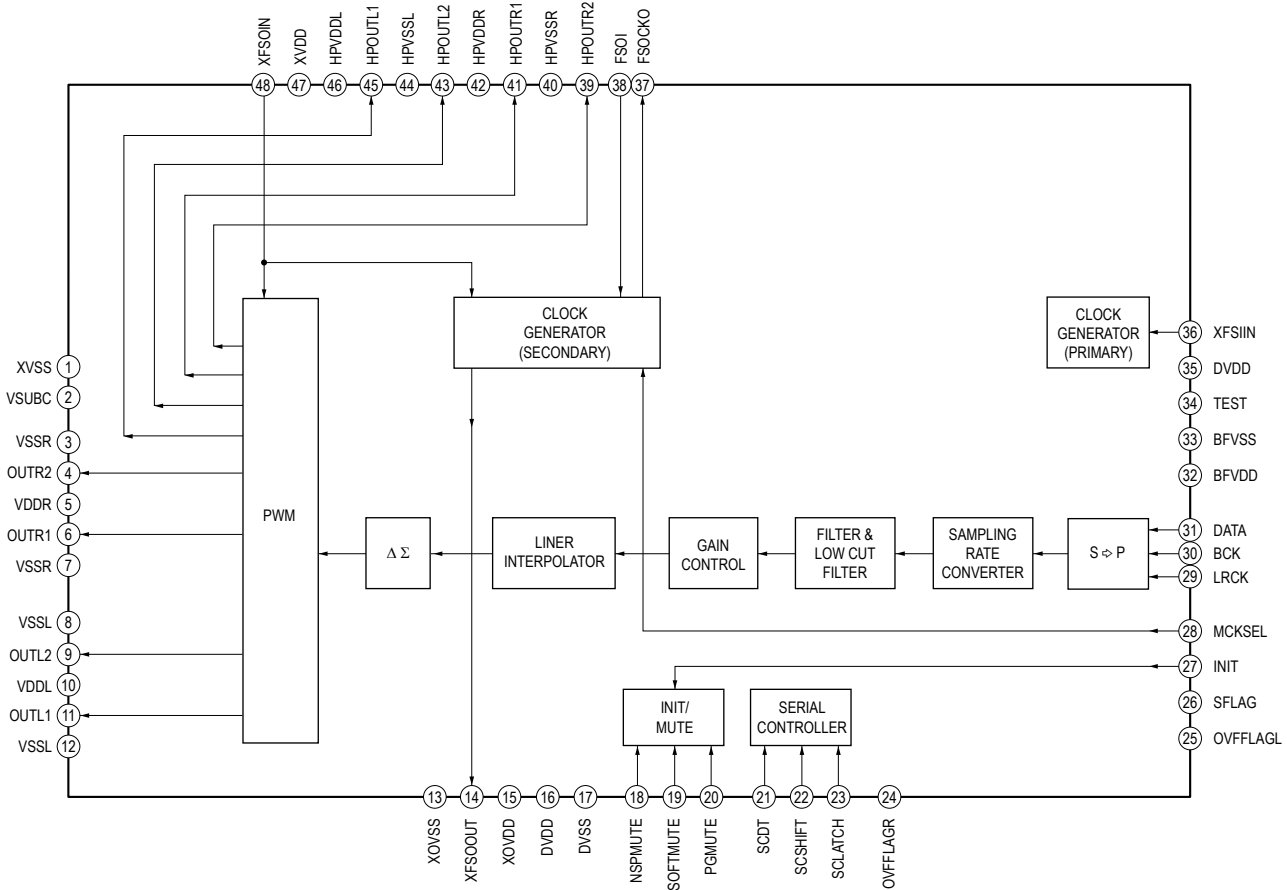

IC707 CXD9965TN

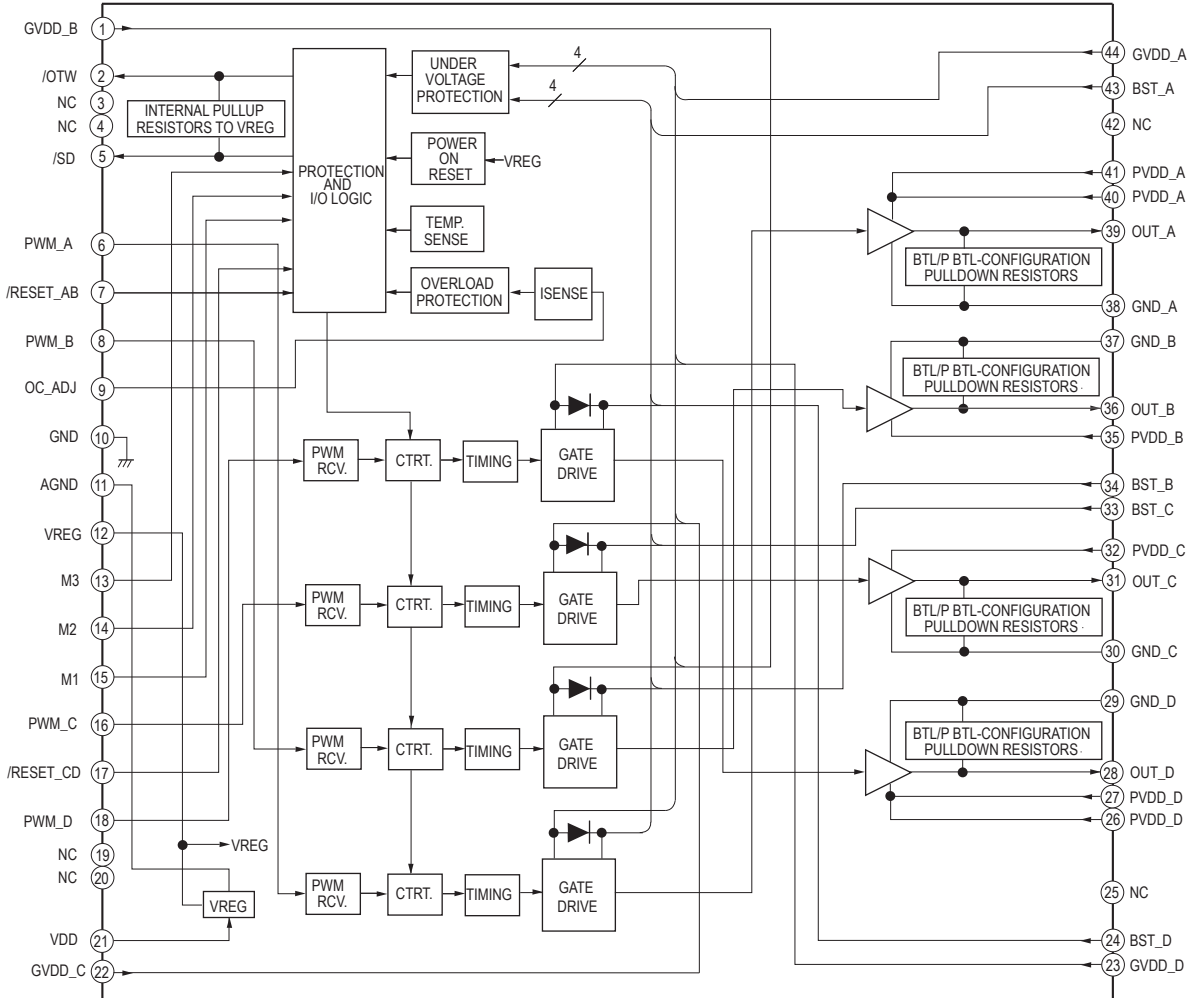

IC711 AK5358BET-E2

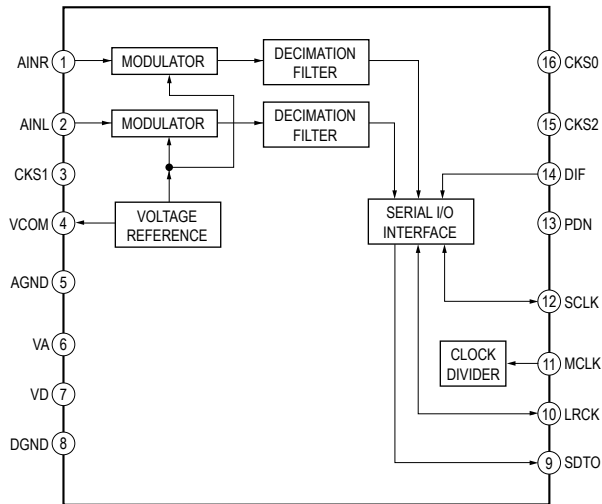

**- FL Board -
IC621 PT6302LQ-010**

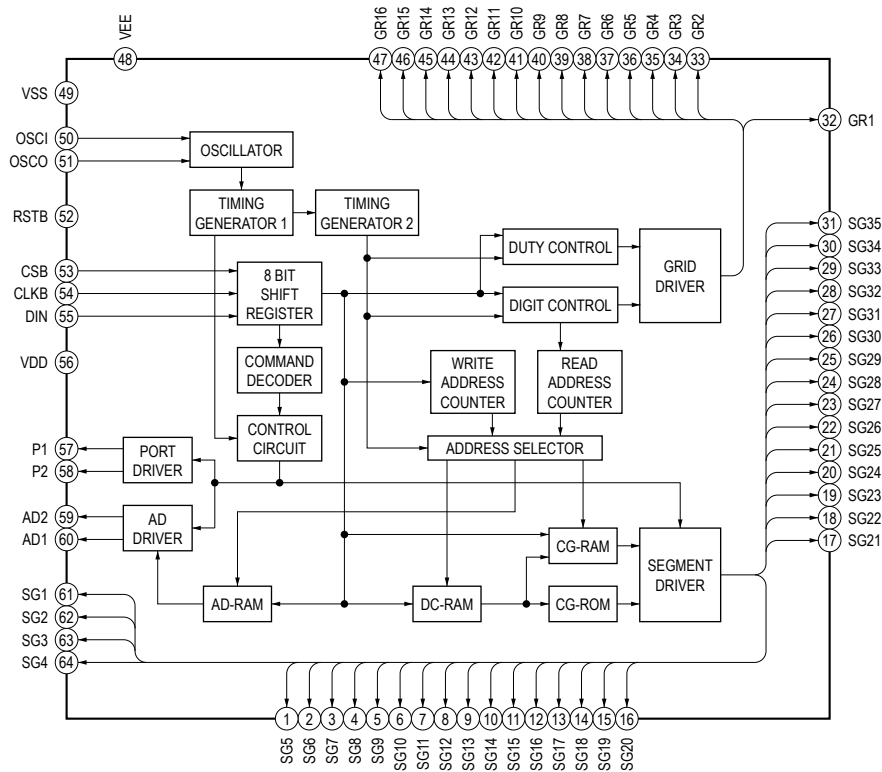

HCD-MX500i/MX550i

- POWER Board -

IC601 MIP2F20MS1SO

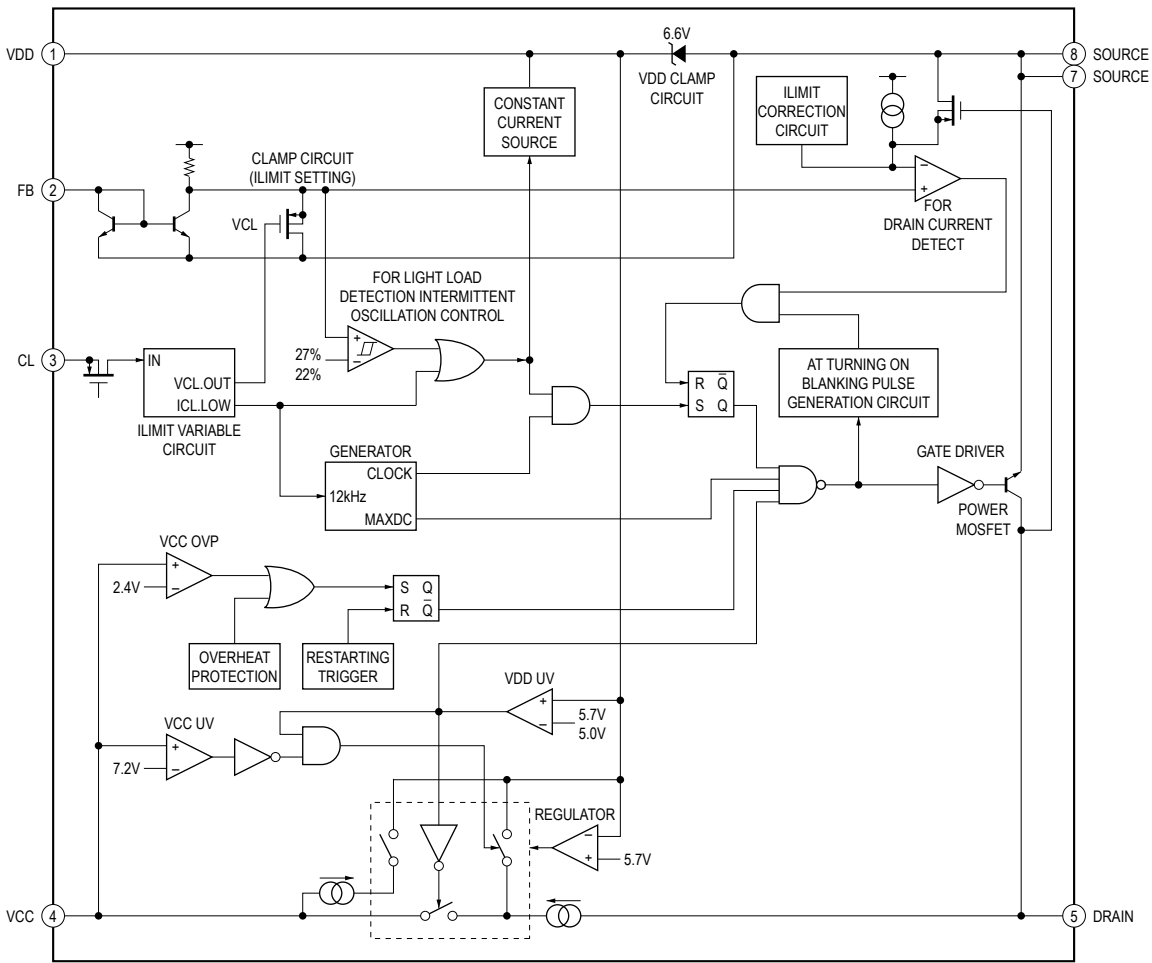

IC904 SI-8001FFEK

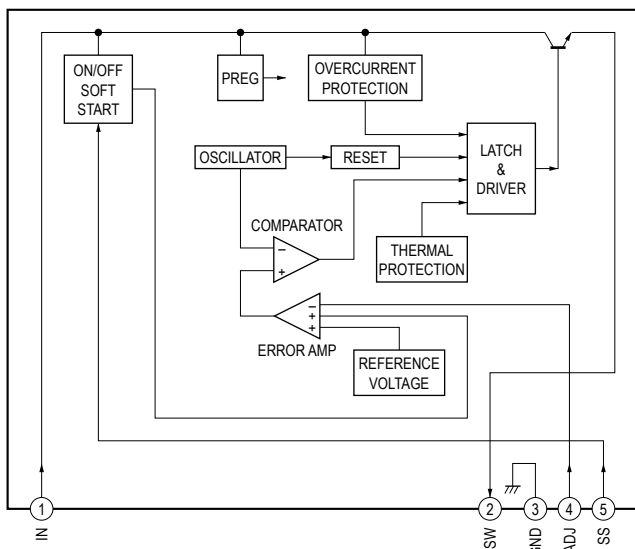

IC905 SI-3010KFEK

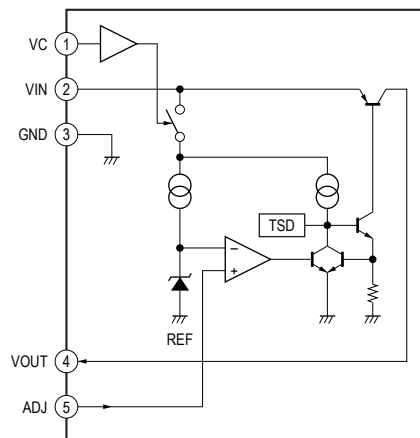

• IC Pin Function Description

BD96 BOARD IC101 TC94A70FG-101 (CD-MP3 PROCESSOR) (Canadian model)

BD96U BOARD IC101 TC94A70FG-101 (CD-MP3 PROCESSOR) (Except Canadian model)

Pin No.	Pin Name	I/O	Description
1	AVSS3	-	Ground terminal
2	RFZI	I	RF ripple zero crossing signal input terminal
3	RFRP	O	RF ripple signal output terminal
4	SBAD	O	Sub beam addition signal output terminal Not used
5	FEO	O	Focus error signal output terminal Not used
6	TEO	O	Tracking error signal output terminal
7	TEZI	I	Tracking error zero crossing signal input terminal
8	AVDD3	-	Power supply terminal (+3.3V)
9	FOO	O	Focus coil drive signal output terminal
10	TRO	O	Tracking coil drive signal output terminal
11	VREF	I	Reference voltage (+1.65V) input terminal
12	FMO	O	Sled motor drive signal output terminal
13	DMO	O	Spindle motor drive signal output terminal
14	VSSP3	-	Ground terminal
15	VCOI	I	VCO control voltage input terminal
16	VDDP3	-	Power supply terminal (+3.3V)
17	VDD1	-	Power supply terminal (+1.5V)
18	VSS1	-	Ground terminal
19	FGIN	I	FG signal input terminal Not used
20	IN_SW	I	Disc inner position detection signal input terminal
21	/DFCT	O	Not used
22	XVSS3	-	Ground terminal
23	XI	I	System clock input terminal (16.934 MHz)
24	XO	O	System clock output terminal (16.934 MHz)
25	XVDD3	-	Power supply terminal (+3.3V)
26	DVSS3	-	Ground terminal
27	ROUT	O	Audio data (R-ch) output to the input selector
28	DVDD3	-	Power supply terminal (+3.3V)
29	DVR	O	Reference voltage (+1.65V) output terminal
30	LOUT	O	Audio data (L-ch) output to the input selector
31	DVSS3	-	Ground terminal
32	VDDT3	-	Power supply terminal (+3.3V)
33	VSS1	-	Ground terminal
34	VDD1	-	Power supply terminal (+1.5V)
35	VDDM1	-	Power supply terminal (+1.5V)
36	SRAMSTB	I	S-RAM standby mode control signal input terminal Fixed at "L" in this set
37	XRST	I	Reset signal input from the system controller "L": reset
38 to 41	BUS0 to BUS3	I	Serial data input from the system controller (Canadian model) Serial data input from the system controller and USB controller (Except Canadian model)
42	BUCK	I	Serial data transfer clock signal input from the system controller
43	XCCE	I	Chip enable signal input from the system controller
44	TEST	I	Setting terminal for test mode Normally fixed at "L"
45	IRQ	I	Interrupt request signal input terminal Not used
46	ST_REQ/CKO	O	Request signal output terminal Not used
47	AOUT2	O	Audio data output terminal (Except Canadian model only)
48	REQ	O	Request signal output to the system controller (Canadian model) Request signal output to the system controller and USB controller (Except Canadian model)
49	PIO1/ST_REQ	O	Request signal output to the USB controller (Except Canadian model only)
50	PIO2	O	Not used
51	GATE	I	Gate signal input terminal (Except Canadian model only)
52	VSS1	-	Ground terminal
53	VDDT3	-	Power supply terminal (+3.3V)
54	SBSY	O	Subcode block sync signal output to the system controller
55	FOK	O	Not used
56	IPF	O	Not used
57	/LOCK	O	Not used

HCD-MX500i/MX550i

Pin No.	Pin Name	I/O	Description
58	ZDET	O	Zero detection signal output terminal Not used
59	GPIN	I	Not used
60	MS	I	Micro controller interface mode selection signal input terminal Fixed at "H" in this set
61	DOUT	O	Digital audio data output terminal Not used
62	AOUT1	O	Audio data output terminal Not used
63	BCKO	O	Bit clock signal output terminal (Except Canadian model only)
64	LRCKO	O	L/R sampling clock signal output terminal Not used
65	AIN	I	Digital audio data input terminal (Except Canadian model only)
66	BCKI	I	Bit clock signal input terminal (Except Canadian model only)
67	LRCKI	I	L/R sampling clock signal input terminal (Except Canadian model only)
68	VDD1	-	Power supply terminal (+1.5V)
69	VSS1	-	Ground terminal
70	AWRC	-	Not used
71	PVDD3	-	Power supply terminal (+3.3V)
72	PDO	O	Phase error margin signal between EFM signal and PLCK signal output terminal
73	TMAXS	O	TMAX detection signal output terminal Not used
74	TMAX	O	TMAX detection signal output terminal
75	LPFN	I	Inverted signal input from the operation amplifier for PLL loop filter
76	LPFO	O	Signal output from the operation amplifier for PLL loop filter
77	PVREF	I	Reference voltage (+1.65V) input terminal
78	VCOF	O	VCO filter output terminal
79	PVSS3	-	Ground terminal
80	SLCO	O	EFM slice level output terminal
81	RFI	I	RF signal input terminal
82	RFRPI	I	RF ripple signal input terminal
83	RFEQ0	O	EFM slice level output terminal
84	VRO	O	Reference voltage (+1.65V) output terminal
85	RESIN	O	External resistor connection terminal
86	VMDIR	O	Reference voltage (+1.65V) output terminal for automatic power control circuit
87	TESTR	O	Low-pass filter terminal for RFEQ0 offset correction
88	AGCI	I	RF signal amplitude adjustment amplification input terminal
89	RFO	O	RF signal generation amplification output terminal
90	RVDD3	-	Power supply terminal (+3.3V)
91	LDO	O	Laser diode on/off control signal output to the automatic power control circuit "H": laser diode on
92	MDI	I	Light amount monitor input from the laser diode of optical pick-up block
93	RVSS3	-	Ground terminal
94	C	I	Main beam (D) input from the optical pick-up block
95	A	I	Main beam (B) input from the optical pick-up block
96	D	I	Main beam (C) input from the optical pick-up block
97	B	I	Main beam (A) input from the optical pick-up block
98	F	I	Sub beam (F) input from the optical pick-up block
99	TNPC	O	External capacitor connection terminal
100	E	I	Sub beam (E) input from the optical pick-up block

BD96U BOARD IC401 92CD28AFG-7FU8 (M (USB CONTROLLER))

Pin No.	Pin Name	I/O	Description
1	USB-RST	I	Reset signal input from the system controller "L": reset
2	I-USB-DI	I	Ready to send signal input from the system controller
3, 4	INT1, INT2	O	Not used
5	INT3	I	Function selection signal input terminal Fixed at "H" in this set
6	DVCC3B	-	Power supply terminal (+3.3V)
7 to 9	XT1, XT2, PWE	-	Not used
10	DVSS1B	-	Ground terminal
11	DVCC1B	-	Power supply terminal Not used
12	RVOUT1	O	Reference voltage (+3.3V) output terminal Not used
13, 14	RVIN	I	Reference voltage (+3.3V) input terminal
15	RVOUT2	O	Reference voltage (+3.3V) output terminal Not used
16	DVCC1A	-	Power supply terminal Not used
17	DVSS1A	-	Ground terminal
18 to 25	D0 to D7	I/O	Two-way data bus with the S-RAM
26	DVSS	-	Ground terminal
27	DVCC3A	-	Power supply terminal (+3.3V)
28 to 35	D8 to D15	I/O	Two-way data bus with the S-RAM
36	A0	O	Address signal output terminal Not used
37 to 43	A1 to A7	O	Address signal output to the S-RAM
44	DVSS	-	Ground terminal
45	DVCC3A	-	Power supply terminal (+3.3V)
46 to 54	A8 to A16	O	Address signal output to the S-RAM
55 to 58	BUS0-U to BUS3-U	O	Serial data output to the CD-MP3 processor
59	BUCK-U	O	Serial data transfer clock signal output to the CD-MP3 processor
60	CCE-U	O	Chip enable signal output to the CD-MP3 processor
61	A23	O	Not used
62	DVSS	-	Ground terminal
63	DVCC3A	-	Power supply terminal (+3.3V)
64	RD	O	Output enable signal output to the S-RAM
65	SRWR	O	Write enable signal output to the S-RAM
66	SRLLB	O	Lower-byte control signal output to the S-RAM
67	SRLUB	O	Upper-byte control signal output to the S-RAM
68	TA0IN	O	Not used
69	BOOT	I	Boot mode selection signal input terminal "L": boot mode
70	SRAM-CS	O	Chip select signal output to the S-RAM
71	LRCK	O	L/R sampling clock signal output to the CD-MP3 processor
72	AM1	I	Function mode selection signal input terminal Fixed at "H" in this set
73	X2	O	System clock output terminal (9 MHz)
74	DVSS	-	Ground terminal
75	X1	I	System clock input terminal (9 MHz)
76	DVCC3A	-	Power supply terminal (+3.3V)
77	USBOC	I	Over current detection signal input terminal
78	USBPON	O	USB VBUS power on/off control signal output terminal "H": power on
79	D+	I/O	Two-way data (positive) bus with the USB connector
80	D-	I/O	Two-way data (negative) bus with the USB connector
81	AM0	I	Function mode selection signal input terminal Fixed at "H" in this set
82	X1USB	O	Not used
83	DVSS	-	Ground terminal
84	O-USB-DO	O	Clear to send signal output to the system controller
85	DATA	I	Audio data input from the CD-MP3 processor
86	CLK	I	Audio data transfer clock signal input from CD-MP3 processor
87	O-USB-SO	O	Serial data output to the system controller
88	I-USB-SI	I	Serial data input from the system controller
89	SPCLK	-	Not used
90	SO0	-	Not used
91	SI0	-	Not used
92	BCK	O	Bit clock signal output to the CD-MP3 processor
93	A-IN	O	Audio data output to the CD-MP3 processor

HCD-MX500i/MX550i

Pin No.	Pin Name	I/O	Description
94	GATE	O	Gate signal output to the CD-MP3 processor
95	DVCC3A	-	Power supply terminal (+3.3V)
96	REQ-U	I	Request signal input from the CD-MP3 processor
97	ST-REQ	I	Request signal input from the CD-MP3 processor
98, 99	PG1, PG0	I	Function selection signal input terminal Fixed at "H" in this set
100	DVSS	-	Ground terminal

MAIN BOARD IC401 R5F364AEDFA (SYSTEM CONTROLLER)

Pin No.	Pin Name	I/O	Description
1	FL/LCD DO	O	Serial data output to the fluorescent indicator tube driver
2	FL/LCD SCL	O	Serial data transfer clock signal output to the fluorescent indicator tube driver
3	FL/LCD CS	O	Chip select signal output to the fluorescent indicator tube driver
4	SIRCS	I	SIRCS signal input from the remote control receiver
5	BCo_SPI_DOUT	O	Serial data output terminal Not used
6	BCo_SPI_DIN	I	Serial data input terminal Not used
7	BCo_SPI_CLK	O	Serial data transfer clock signal output terminal Not used
8	BYTE	I	External data bus width selection signal input terminal
9	CNVss	I	Processor mode selection signal input terminal
10	Xcin	I	Sub system clock input terminal (32.768 kHz)
11	Xcout	O	Sub system clock output terminal (32.768 kHz)
12	RESET	I	System reset signal input terminal
13	Xout	O	Main system clock output terminal (5 MHz)
14	Vss	-	Ground terminal
15	Xin	I	Main system clock input terminal (5 MHz)
16	Vcc	-	Power supply terminal (+3.3V)
17	NMI	-	Not used
18	RDS-INT	I	RDS interrupt signal input from the tuner (FM) (MX500i: AEP/MX550i only)
19	SBSY	I	Subcode block sync signal input from the CD-MP3 processor
20	AC-CUT	I	AC cut on/off detection signal input terminal "L": AC cut on
21	BCo_POWER	O	Power on/off control signal output terminal Not used
22	iPod CP IIC SCL	O	Serial data transfer clock signal output to the EEPROM
23	BCo_SPI_CS	O	Chip select signal output terminal Not used
24	iPod CP IIC SDA	O	Serial data output to the EEPROM
25	BCo_RESET	O	Reset signal output terminal Not used
26	iPod CP RESET	O	Reset signal output to the EEPROM
27	USB_RESET	O	System reset signal output to the USB controller "L": reset (Except Canadian model only)
28	USB_CTS	I	Clear to send signal input from the USB controller (Except Canadian model only)
29, 30	no use	-	Not used
31	USB_TxD_OUT	O	Serial data output to the USB controller (Except Canadian model only)
32	USB_RxD_IN	I	Serial data input from the USB controller (Except Canadian model only)
33	USB_RTS	O	Ready to send signal output to the USB controller (Except Canadian model only)
34	S-MASTER_DCP	I	Over load detection signal input terminal
35	DAB TxD_OUT	O	Serial data output terminal for the DAB tuner module (MX550i only)
36	DAB RxD_IN	I	Serial data input terminal for the DAB tuner module (MX550i only)
37	S-MASTER_PG_MUTE	O	PG muting on/off control signal output to stream processor
38	S-MASTER_SOFT_MUTE	O	Soft muting on/off control signal output to stream processor
39	S-MASTER_RESET	O	Reset signal output to the digital power amplifier
40	S-MASTER_DATA	O	Serial data output to the stream processor
41	LCD BACKLIGHT	O	LED drive signal output terminal Not used
42	S-MASTER_SHIFT	O	Serial data transfer clock signal output to the stream processor
43	S-MASTER_LATCH	O	Serial data latch pulse signal output to the stream processor
44	S-MASTER_NSPMUTE	O	NSP muting on/off control signal output to stream processor
45	S-MASTER_INIT	O	Reset signal output to the stream processor
46	STBY_LED	O	LED drive signal output terminal for STANDBY indicator
47	VOL IIC_SDA/E2P-SDA	O	Serial data output to the electrical volume
48	VOL IIC_CLK/E2P-CLK	O	Serial data transfer clock signal output to the electrical volume
49	DAB-POWER_3.3	O	Power supply on/off control signal output terminal for the DAB tuner module (+3.3V) (MX550i only)
50	DAB-POWER_1.2	O	Power supply on/off control signal output terminal for the DAB tuner module (+1.2V) (MX550i only)
51	ST_TUNED	I	Tuned detection signal input from the tuner (FM)
52	ST_CE	O	Chip enable signal output to the tuner (FM)
53	ST_DO	O	Serial data output to the tuner (FM)
54	ST_CLK	O	Serial data transfer clock signal output to the tuner (FM)
55	ST_DI/STEREO	I	Serial data input from the tuner (FM)
56	RDS_DATA	I	RDS data input from the tuner (FM) (MX500i: AEP/MX550i only)
57	CDM_OPEN_SW	I	Switch detection signal input terminal for loading section

HCD-MX500i/MX550i

Pin No.	Pin Name	I/O	Description
58	CDM_CLOSE_SW	I	Switch detection signal input terminal for loading section
59	CDM_LOAD_IN	O	Motor drive signal output terminal for the loading section
60	CDM_LOAD_OUT	O	Motor drive signal output terminal for the loading section
61	FL/LCD RESET	O	Reset signal output to the fluorescent indicator tube driver
62	Vcc	-	Power supply terminal (+3.3V)
63	POWER ON	O	Main power on/off control signal output terminal "H": main power on
64	Vss	-	Ground terminal
65	SPEC_IN	I	Destination setting terminal
66	AUDIO_LEVEL_INPUT	I	Audio level detection signal input terminal
67	BCo_SPI_REQ	I	Request signal input terminal Not used
68	BCo_SPI_READY	O	Ready signal output terminal Not used
69	AC_DET	I	Power failure detection signal input terminal
70, 71	KEY_1, KEY_2	I	Panel key input terminal (A/D input)
72	VOLUME_JOG	I	Jog dial pulse input from the rotary encoder (for VOLUME)
73	BYPASS	O	System shut down signal output terminal
74	I_KEY WAKE UP_ POWER & DISPLAY	I	Key wake-up signal input terminal
75	iPod_WAKE	I	Wake-up signal input from the iPod/iPhone Dock
76	iPod_DET	I	iPod/iPhone detection signal input terminal
77	iPod_TxD_OUT	O	Serial data output to the iPod/iPhone Dock
78	iPod_RxD_IN	I	Serial data input from the iPod/iPhone Dock
79	NC	-	Not used
80	HP_DET	I	Headphone detection signal input terminal
81	HP_MUTE	-	Not used
82	TA_LINE_MUTE	O	Line muting on/off control signal output terminal
83	POWER_PROTECT	I	Power monitor signal input terminal
84	SINGER_ON	O	Power supply on/off control signal output terminal Not used
85	BOLERO/iPod_ON	O	Power supply on/off control signal output terminal for the USB/iPod section
86	ZIPANG_ON	O	Power supply on/off control signal output terminal for the CD section
87	CD_XRST	O	Reset signal output to the CD-MP3 processor
88	CD_DRIVER_MUTE	O	Motor drive on/off control signal output to the motor/coil driver
89	MP3_IREQ	I	Request signal input from the CD-MP3 processor
90	CD CCE	O	Chip enable signal output to the CD-MP3 processor
91	CD CLK	O	Serial data transfer clock signal output to the CD-MP3 processor
92	DEC BUS SEL	O	Function selection signal output terminal
93 to 95	CD BUS3 to CD BUS1	O	Serial data output to the CD-MP3 processor
96	Avss	-	Ground terminal
97	CD BUS0	O	Serial data output to the CD-MP3 processor
98	VREF	I	Reference voltage (+3.3V) input terminal
99	Avcc	-	Power supply terminal (+3.3V)
100	LCD_DI	I	Not used

POWER BOARD IC11 CXD9841P (POWER CONTROL)

Pin No.	Pin Name	I/O	Description
1	VSENSE	I	AC line input voltage detection signal input terminal
2	F/B	I	Feedback signal input terminal for frequency modulation of oscillator
3	CT	-	External capacitor connection terminal for oscillator
4	RT	-	External resistor connection terminal for oscillator
5	GND	-	Ground terminal
6	PROTECT	-	External capacitor connection terminal for intermittent operation timer when abnormality detecting it
7	SS	-	External capacitor connection terminal for soft start
8	VC1	I	Power supply terminal for control circuit "L": stop, "H": operation start
9	OCP	I	Over current detection signal and DIDT protection signal input terminal
10	VC2	O	Power supply output terminal for driver
11	P-GND	I	Ground terminal for lower side driver
12	VG-L	O	Lower side driver drive signal output terminal
13	-	-	Not used
14	VB	I	Power supply terminal for upper side driver
15	VS	I	Reference power supply input terminal for upper side driver
16	VG-H	O	Upper side driver drive signal output terminal
17	-	-	Not used
18	VD	-	Terminal for drain kick start

6-2. FRONT PANEL SECTION

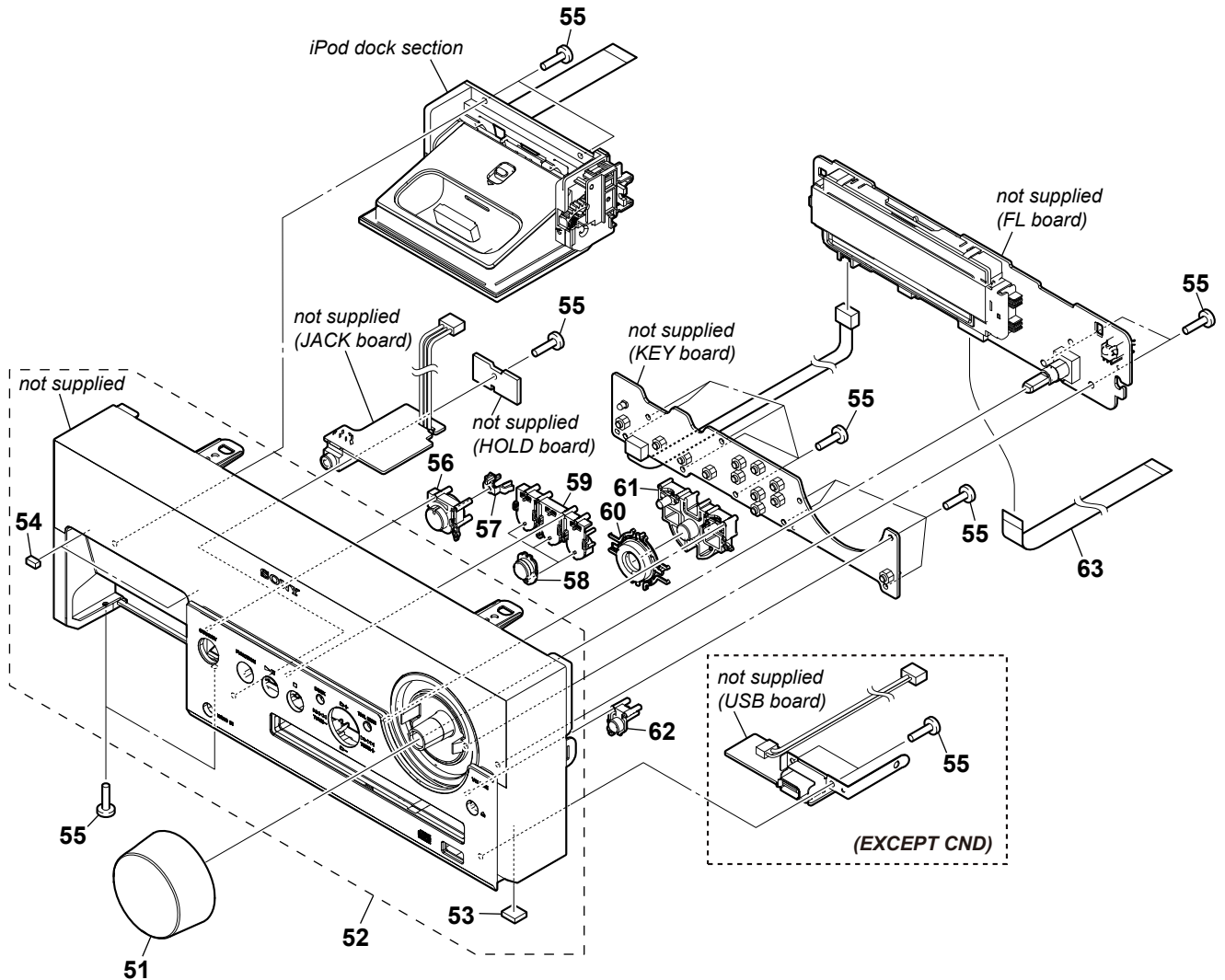

Ref. No.	Part No.	Description	Remark	Ref. No.	Part No.	Description	Remark
51	4-175-912-01	KNOB (VOL)		57	4-175-917-01	INDICATOR (POWER)	
52	X-2548-810-1	PANEL (FRONT MX500 CEL) ASSY (MX500i: AEP)		58	4-175-920-01	CAP (BUTTON)	
52	X-2548-811-1	PANEL (FRONT MX550) ASSY (MX550i)		59	4-175-915-01	BUTTON (PLAY) (FUNCTION, ► , ■)	
52	X-2549-182-1	PANEL (FRONT MX500 CA) ASSY (MX500i: CND)		60	4-175-919-01	BUTTON (TUNE) (◀+▲, ▼◻-, ◻◀◀ TUNE -, ▶▶▶ TUNE +)	
52	X-2549-183-1	PANEL (FRONT MX500 SP) ASSY (MX500i: CH, SP)		61	4-175-918-01	BUTTON (ENTER) (DSGX, TOOL MENU, ENTER)	
53	3-198-753-01	FOOT (FELT)		62	4-175-916-01	BUTTON (EJECT) (▲)	
54	4-186-748-01	CUSHION (IP)		63	1-832-578-21	CABLE, FLEXIBLE FLAT (13 CORE)	
55	3-087-053-01	+BVTP2.6 (3CR)					
56	4-175-914-01	BUTTON (POWER) (I/⏻)					

6-3. iPod DOCK SECTION

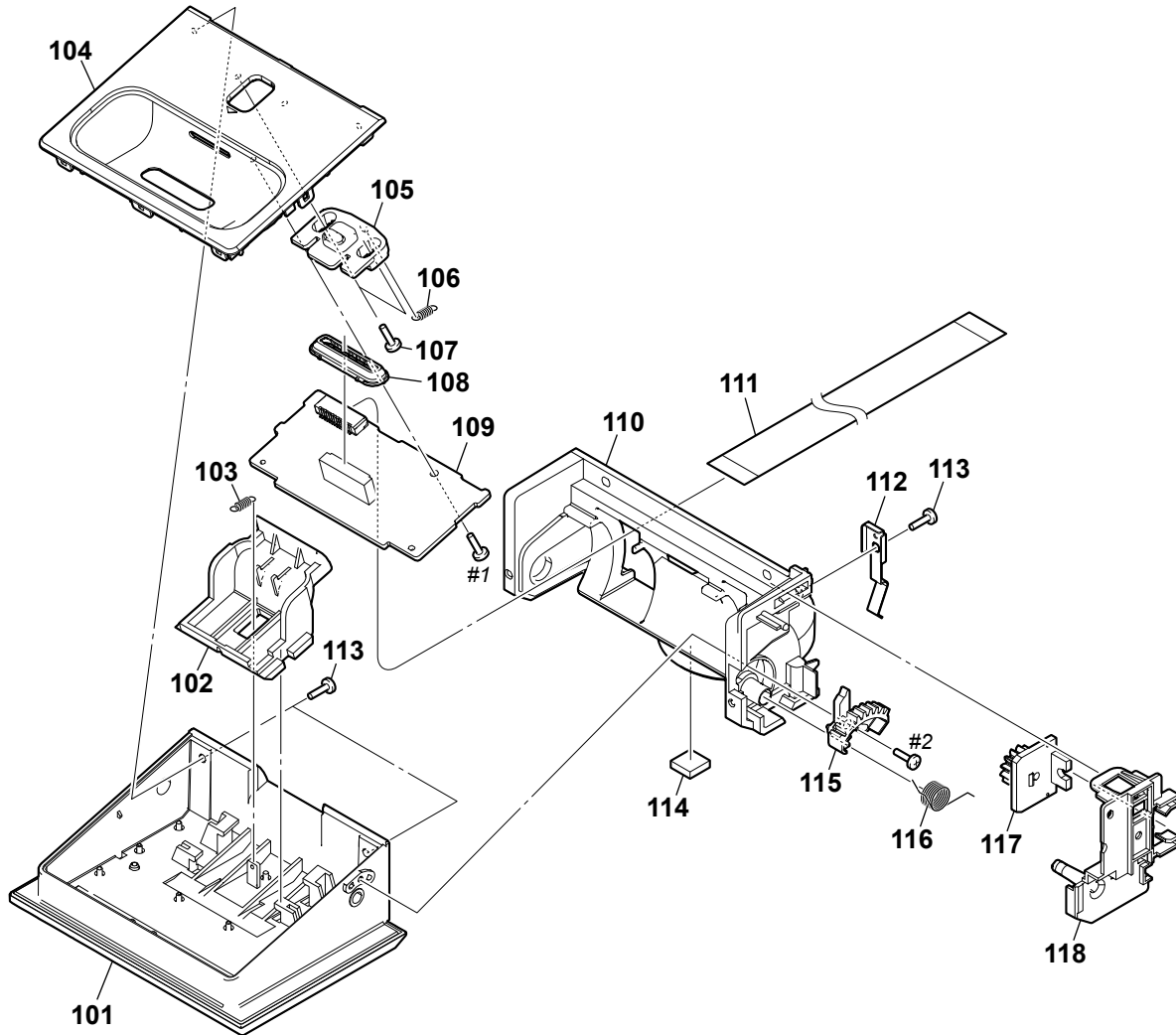

Ref. No.	Part No.	Description	Remark	Ref. No.	Part No.	Description	Remark
101	X-2548-813-1	BASE (LOWER MX500) ASSY (MX500i)		111	1-838-389-21	CABLE, FLEXIBLE FLAT (13 CORE)	
101	X-2548-821-1	BASE (LOWER MX550) ASSY (MX550i)		112	4-175-952-01	SPRING (CLOSE), LEAF	
102	4-175-945-01	SLIDER (LOCK)		113	3-087-053-01	+BVTP2.6 (3CR)	
103	4-192-357-01	SPRING (SLIDER), EXTENSION		114	3-198-753-01	FOOT (FELT)	
104	X-2548-812-1	BASE (UPPER) ASSY		115	4-175-943-01	GEAR (LOCK)	
105	4-175-944-01	LEVER (LOCK)		116	4-175-951-01	SPRING (IP), TORSION	
106	4-175-950-01	SPRING (LOCK), EXTENSION		117	3-047-468-01	DAMPER	
107	3-669-480-32	+ PTPWH (2X5)		118	4-175-942-01	HOLDER (DAMPER)	
108	3-277-576-01	ESCUTCHEON		#1	7-685-504-19	SCREW +BTP 2X6 TYPE2 N-S	
109	A-1760-782-A	IP BOARD, COMPLETE		#2	7-685-106-19	SCREW +P 2X10 TYPE2 NON-SLIT	
110	4-175-938-01	PANEL (DOCK), FRONT					

6-4. MAIN BOARD SECTION

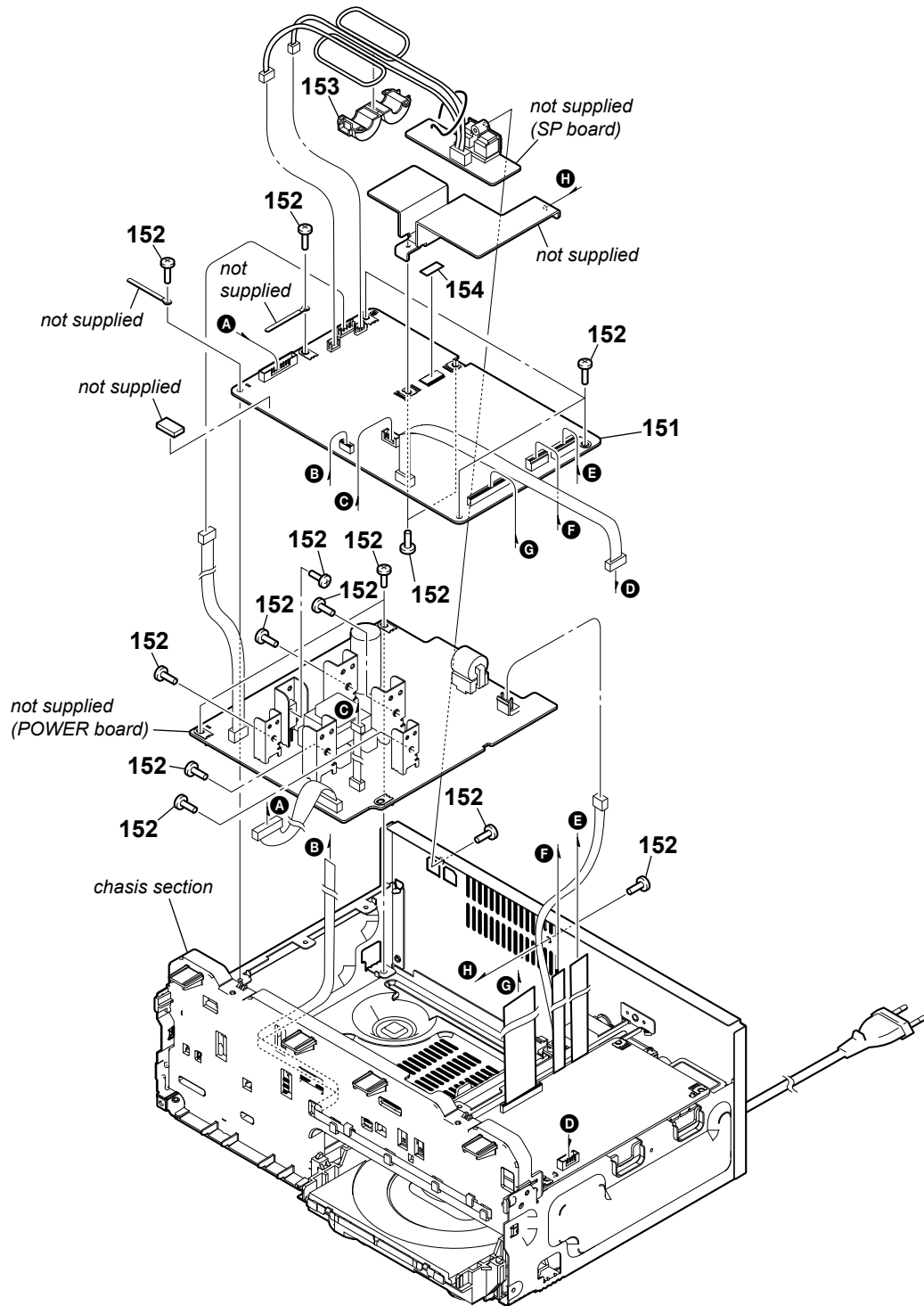

Ref. No.	Part No.	Description	Remark	Ref. No.	Part No.	Description	Remark
151	A-1760-771-A	MAIN BOARD, COMPLETE (MX500i: AEP)		152	3-077-331-01	+BV3 (3-CR)	
151	A-1760-784-A	MAIN BOARD, COMPLETE (MX500i: CND)					
151	A-1760-905-A	MAIN BOARD, COMPLETE (MX550i)		153	1-400-932-11	FILTER, CLAMP	
151	A-1783-490-A	MAIN BOARD, COMPLETE (MX500i: CH, SP)		154	4-183-177-01	SHEET, RADIATION	

6-5. CHASSIS SECTION

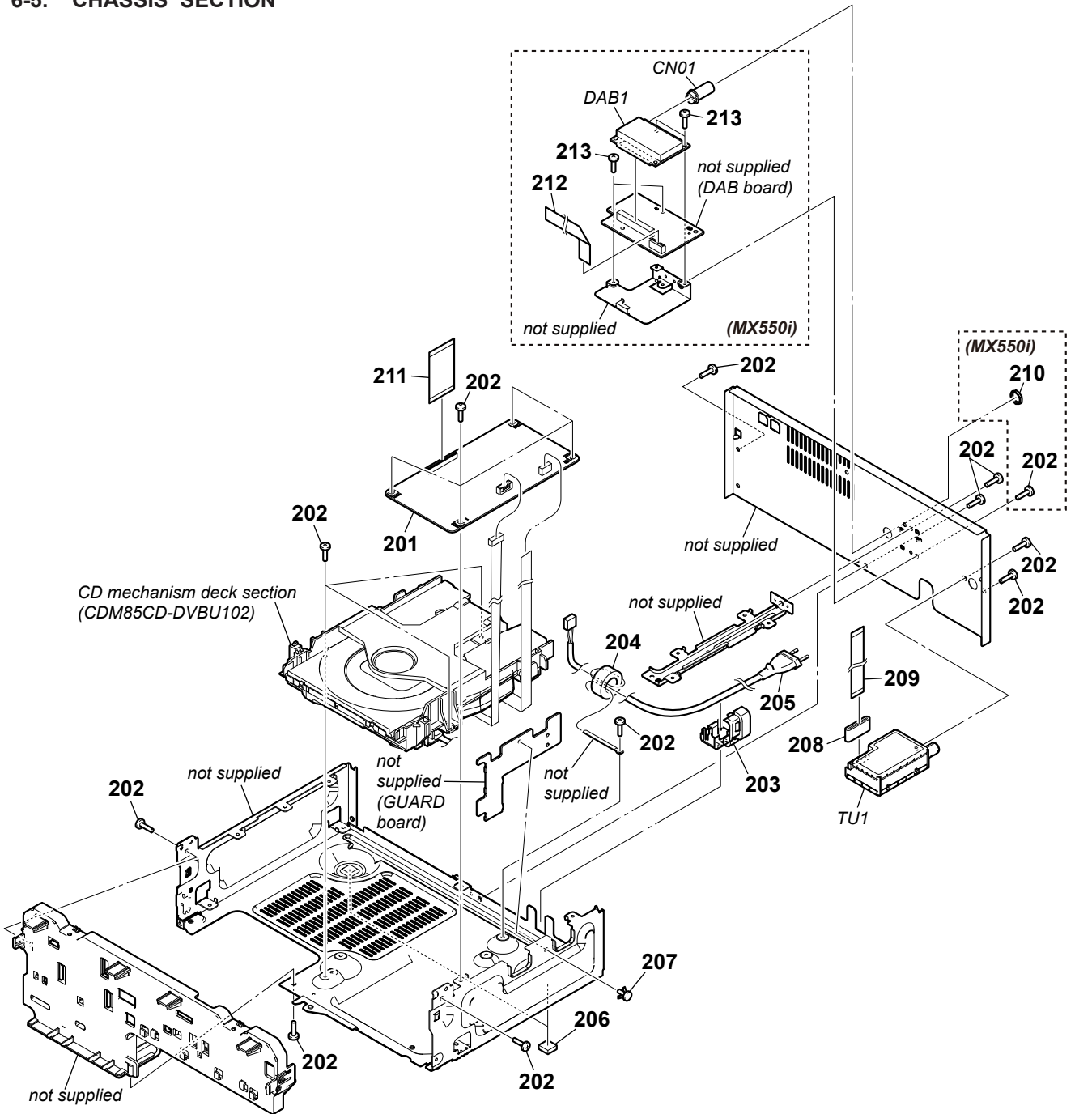

Ref. No.	Part No.	Description	Remark	Ref. No.	Part No.	Description	Remark
201	A-1759-698-A	BD96 BOARD, COMPLETE (CND)		210	2-650-108-01	NUT (MX550i)	
201	A-1759-699-A	BD96U BOARD, COMPLETE (EXCEPT CND)		211	1-832-601-21	CABLE, FLEXIBLE FLAT (19 CORE) (CND)	
202	3-077-331-01	+BV3 (3-CR)		211	1-832-641-21	CABLE, FLEXIBLE FLAT (27 CORE)	(EXCEPT CND)
203	3-703-244-00	BUSHING (2104), CORD		212	1-832-554-21	CABLE, FLEXIBLE FLAT (9 CORE) (MX550i)	
204	1-481-419-11	CORE, FERRITE		213	3-023-547-01	SCREW (2.6X6), +BTT (MX550i)	
△ 205	1-834-966-41	POWER-SUPPLY CORD (AEP, SP)		CN01	1-820-441-11	CONNECTOR, COAXIAL (F TYPE) (MX550i)	
△ 205	1-835-078-31	CORD, POWER (UK)		DAB1	1-487-958-21	MODULE (DAB TUNER) (MX550i)	
△ 205	1-837-308-11	CORD, POWER-SUPPLY (CND)		TU1	1-693-780-11	TUNER (FM) (SP)	
△ 205	1-837-822-21	CORD, POWER-SUPPLY (CH)		TU1	1-693-781-11	TUNER (FM) (CND)	
206	3-198-753-01	FOOT (FELT)		TU1	1-693-787-11	TUNER (FM) (AEP, UK)	
207	3-531-576-11	RIVET		TU1	1-693-788-11	TUNER (FM) (CH)	
208	1-400-092-11	CORE, FERRITE					
209	1-832-814-21	CABLE, FLEXIBLE FLAT (9 CORE) (CND, CH, SP)					
209	1-832-824-21	CABLE, FLEXIBLE FLAT (11 CORE) (AEP, UK)					

6-6. CD MECHANISM DECK SECTION (CDM85CD-DVBU102)

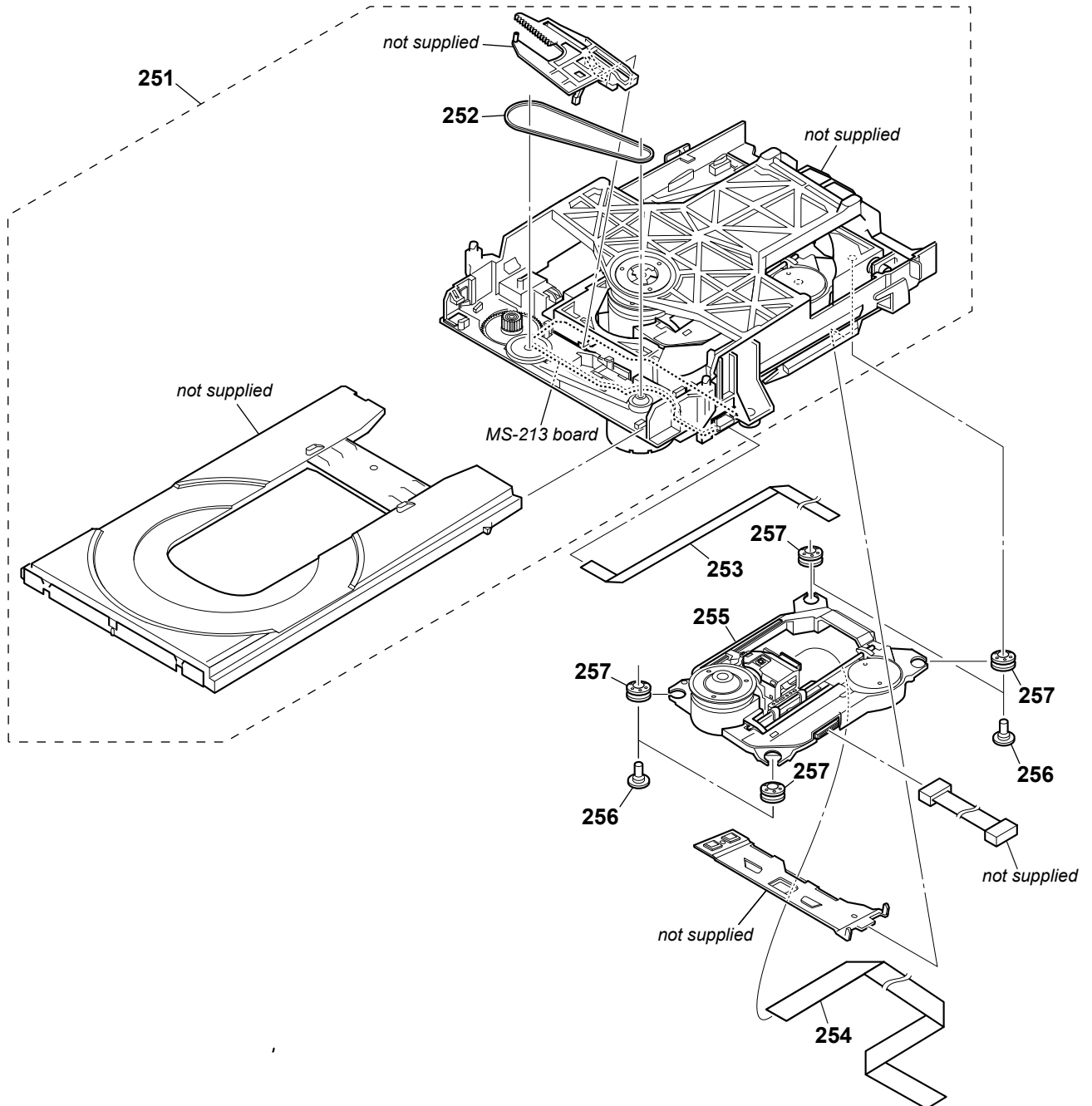

Ref. No.	Part No.	Description	Remark	Ref. No.	Part No.	Description	Remark
△ 251	A-1764-002-A	CDM85 (CD) ASSY (Including MS-213 board)		△ 255	8-820-321-05	DEVICE, OPTICAL KHM-313CAA/C2RP	
252	3-088-371-01	BELT		256	4-985-672-01	SCREW (+PTPWH M2.6), FLOATING	
253	1-832-539-21	CABLE, FLEXIBLE FLAT (5 CORE)		257	4-168-623-01	INSULATOR (85CD)	
254	1-830-688-51	WIRE (FLAT TYPE) (24 CORE)					

SECTION 7
ELECTRICAL PARTS LIST

BD96/BD96U

Note:

- Due to standardization, replacements in the parts list may be different from the parts specified in the diagrams or the components used on the set.
- -XX and -X mean standardized parts, so they may have some difference from the original one.
- Items marked "*" are not stocked since they are seldom required for routine service. Some delay should be anticipated when ordering these items.
- RESISTORS
All resistors are in ohms.
METAL: Metal-film resistor.
METAL OXIDE: Metal oxide-film resistor.
F: nonflammable

- CAPACITORS
uF: μ F
- COILS
uH: μ H
- SEMICONDUCTORS
In each case, u: μ , for example:
uA. . . : μ A. . . , uPA. . . , μ PA. . . ,
uPB. . . : μ PB. . . , uPC. . . , μ PC. . . ,
uPD. . . : μ PD. . .
- Abbreviation
CH : Chinese model
CND : Canadian model
SP : Singapore model

When indicating parts by reference number, please include the board name.

The components identified by mark Δ or dotted line with mark Δ are critical for safety.
Replace only with part number specified.

Les composants identifiés par une marque Δ sont critiques pour la sécurité.
Ne les remplacer que par une pièce portant le numéro spécifié.

原理图和零件清单中标有 Δ 记号的零部件, 或带有 Δ 记号的虚线所圈示的零部件, 对于维系安全至关重要。因此只能以指定号码的零部件来更换。

Ref. No.	Part No.	Description	Remark	Ref. No.	Part No.	Description	Remark
	A-1759-698-A	BD96 BOARD, COMPLETE (CND)		C149	1-165-908-11	CERAMIC CHIP 1uF 10%	10V
	A-1759-699-A	BD96U BOARD, COMPLETE (EXCEPT CND)		C157	1-164-937-11	CERAMIC CHIP 0.001uF 10%	50V
		*****		C158	1-164-937-11	CERAMIC CHIP 0.001uF 10%	50V
		< CAPACITOR >		C159	1-164-937-11	CERAMIC CHIP 0.001uF 10%	50V
C101	1-165-908-11	CERAMIC CHIP 1uF	10% 10V	C160	1-164-937-11	CERAMIC CHIP 0.001uF 10%	50V
C103	1-107-826-11	CERAMIC CHIP 0.1uF	10% 16V	C202	1-162-964-11	CERAMIC CHIP 0.001uF 10%	50V
C104	1-164-156-11	CERAMIC CHIP 0.1uF	25V	C203	1-128-995-21	ELECT CHIP 100uF	20% 10V
C105	1-128-995-21	ELECT CHIP 100uF	20% 10V	C204	1-165-908-11	CERAMIC CHIP 1uF	10% 10V
C106	1-107-726-91	CERAMIC CHIP 0.01uF	10% 16V	C207	1-165-908-11	CERAMIC CHIP 1uF	10% 10V
				C208	1-137-710-91	CERAMIC CHIP 10uF	20% 6.3V
C107	1-162-925-11	CERAMIC CHIP 68PF	5% 50V	C210	1-165-908-11	CERAMIC CHIP 1uF	10% 10V
C108	1-162-964-11	CERAMIC CHIP 0.001uF	10% 50V	C211	1-107-826-11	CERAMIC CHIP 0.1uF	10% 16V
C109	1-164-245-11	CERAMIC CHIP 0.015uF	10% 25V	C212	1-107-826-11	CERAMIC CHIP 0.1uF	10% 16V
C110	1-107-726-91	CERAMIC CHIP 0.01uF	10% 16V	C213	1-107-826-11	CERAMIC CHIP 0.1uF	10% 16V
C111	1-162-966-11	CERAMIC CHIP 0.0022uF	10% 50V	C214	1-137-710-91	CERAMIC CHIP 10uF	20% 6.3V
C112	1-107-826-11	CERAMIC CHIP 0.1uF	10% 16V	C216	1-137-710-91	CERAMIC CHIP 10uF	20% 6.3V
C113	1-107-826-11	CERAMIC CHIP 0.1uF	10% 16V	C302	1-107-826-11	CERAMIC CHIP 0.1uF	10% 16V
C114	1-107-726-91	CERAMIC CHIP 0.01uF	10% 16V	C303	1-164-156-11	CERAMIC CHIP 0.1uF	25V
C115	1-164-245-11	CERAMIC CHIP 0.015uF	10% 25V	C305	1-164-156-11	CERAMIC CHIP 0.1uF	25V
C116	1-164-677-11	CERAMIC CHIP 0.033uF	10% 16V	C309	1-128-394-11	ELECT CHIP 220uF	20% 10V
C118	1-162-923-11	CERAMIC CHIP 47PF	5% 50V	C403	1-107-826-11	CERAMIC CHIP 0.1uF	10% 16V (EXCEPT CND)
C119	1-164-156-11	CERAMIC CHIP 0.1uF	25V	C404	1-107-826-11	CERAMIC CHIP 0.1uF	10% 16V (EXCEPT CND)
C122	1-164-677-11	CERAMIC CHIP 0.033uF	10% 16V	C405	1-107-826-11	CERAMIC CHIP 0.1uF	10% 16V (EXCEPT CND)
C123	1-164-156-11	CERAMIC CHIP 0.1uF	25V	C406	1-162-919-11	CERAMIC CHIP 22PF	5% 50V (EXCEPT CND)
C124	1-164-156-11	CERAMIC CHIP 0.1uF	25V	C407	1-162-921-11	CERAMIC CHIP 33PF	5% 50V (EXCEPT CND)
C125	1-164-315-11	CERAMIC CHIP 470PF	5% 50V	C408	1-107-826-11	CERAMIC CHIP 0.1uF	10% 16V (EXCEPT CND)
C126	1-164-315-11	CERAMIC CHIP 470PF	5% 50V	C409	1-107-826-11	CERAMIC CHIP 0.1uF	10% 16V (EXCEPT CND)
C127	1-164-156-11	CERAMIC CHIP 0.1uF	25V	C410	1-124-779-00	ELECT CHIP 10uF	20% 16V (EXCEPT CND)
C128	1-165-176-11	CERAMIC CHIP 0.047uF	10% 16V	C411	1-107-826-11	CERAMIC CHIP 0.1uF	10% 16V (EXCEPT CND)
C129	1-165-176-11	CERAMIC CHIP 0.047uF	10% 16V	C412	1-107-826-11	CERAMIC CHIP 0.1uF	10% 16V (EXCEPT CND)
C130	1-107-826-11	CERAMIC CHIP 0.1uF	10% 16V	C413	1-107-826-11	CERAMIC CHIP 0.1uF	10% 16V (EXCEPT CND)
C131	1-107-826-11	CERAMIC CHIP 0.1uF	10% 16V	C414	1-107-826-11	CERAMIC CHIP 0.1uF	10% 16V (EXCEPT CND)
C132	1-162-966-11	CERAMIC CHIP 0.0022uF	10% 50V	C415	1-124-779-00	ELECT CHIP 10uF	20% 16V (EXCEPT CND)
C133	1-164-156-11	CERAMIC CHIP 0.1uF	25V	C420	1-107-826-11	CERAMIC CHIP 0.1uF	10% 16V (EXCEPT CND)
C134	1-164-156-11	CERAMIC CHIP 0.1uF	25V				
C135	1-164-156-11	CERAMIC CHIP 0.1uF	25V				
C136	1-162-910-11	CERAMIC CHIP 5PF	0.25PF 50V				
C137	1-164-156-11	CERAMIC CHIP 0.1uF	25V				
C138	1-162-910-11	CERAMIC CHIP 5PF	0.25PF 50V				
C139	1-164-156-11	CERAMIC CHIP 0.1uF	25V				
C141	1-124-778-00	ELECT CHIP 22uF	20% 6.3V				
C142	1-164-156-11	CERAMIC CHIP 0.1uF	25V				
C143	1-107-826-11	CERAMIC CHIP 0.1uF	10% 16V				
C145	1-164-156-11	CERAMIC CHIP 0.1uF	25V				
C148	1-165-908-11	CERAMIC CHIP 1uF	10% 10V				

Ref. No.	Part No.	Description	Remark	Ref. No.	Part No.	Description	Remark
C421	1-107-826-11	CERAMIC CHIP 0.1uF	10% 16V (EXCEPT CND)	IC202	6-707-010-01	IC NJM2740V	
				IC203	6-707-010-01	IC NJM2740V	
C422	1-107-826-11	CERAMIC CHIP 0.1uF	10% 16V (EXCEPT CND)	IC301	6-710-637-01	IC BA5826HFP-E2	
C423	1-107-826-11	CERAMIC CHIP 0.1uF	10% 16V (EXCEPT CND)	IC401	6-715-737-01	IC 92CD28AFG-7FU8 (M (EXCEPT CND)	
C424	1-107-826-11	CERAMIC CHIP 0.1uF	10% 16V (EXCEPT CND)	IC402	6-704-832-01	IC IS61LV6416-10TLT (EXCEPT CND)	
C425	1-107-826-11	CERAMIC CHIP 0.1uF	10% 16V (EXCEPT CND)	IC403	8-759-523-03	IC TC74HC4066AFT (EL) (EXCEPT CND)	
C426	1-107-826-11	CERAMIC CHIP 0.1uF	10% 16V (EXCEPT CND)	IC404	8-759-523-03	IC TC74HC4066AFT (EL) (EXCEPT CND)	
C434	1-164-937-11	CERAMIC CHIP 0.001uF	10% 50V (EXCEPT CND)	IC405	6-707-870-01	IC TC74VHC157FT (EKJ) (EXCEPT CND)	
C435	1-164-937-11	CERAMIC CHIP 0.001uF	10% 50V (EXCEPT CND)	IC406	6-715-294-01	IC BD2220G-TR (EXCEPT CND)	
C436	1-165-908-11	CERAMIC CHIP 1uF	10% 10V (EXCEPT CND)	< TRANSISTOR >			
C437	1-165-908-11	CERAMIC CHIP 1uF	10% 10V (EXCEPT CND)	Q201	6-551-120-01	TRANSISTOR 2SA2119K	
C438	1-107-826-11	CERAMIC CHIP 0.1uF	10% 16V (EXCEPT CND)	Q401	8-729-027-43	TRANSISTOR DTC114EKA-T146	(EXCEPT CND)
C501	1-128-995-21	ELECT CHIP 100uF	20% 10V	< RESISTOR >			
C502	1-128-995-21	ELECT CHIP 100uF	20% 10V	R101	1-216-837-11	METAL CHIP 22K 5% 1/10W	
C503	1-128-995-21	ELECT CHIP 100uF	20% 10V	R102	1-216-864-11	SHORT CHIP 0	
C504	1-164-156-11	CERAMIC CHIP 0.1uF	25V	R103	1-216-864-11	SHORT CHIP 0	
C505	1-164-156-11	CERAMIC CHIP 0.1uF	25V	R104	1-216-864-11	SHORT CHIP 0	
C506	1-164-156-11	CERAMIC CHIP 0.1uF	25V	R105	1-216-864-11	SHORT CHIP 0	
C507	1-162-966-11	CERAMIC CHIP 0.0022uF	10% 50V	R106	1-216-864-11	SHORT CHIP 0	
C508	1-162-966-11	CERAMIC CHIP 0.0022uF	10% 50V	R107	1-216-864-11	SHORT CHIP 0	
C512	1-107-826-11	CERAMIC CHIP 0.1uF	10% 16V	R108	1-216-835-11	METAL CHIP 15K 5% 1/10W	
C513	1-128-995-21	ELECT CHIP 100uF	20% 10V (EXCEPT CND)	R109	1-216-864-11	SHORT CHIP 0	
C514	1-164-156-11	CERAMIC CHIP 0.1uF	25V (EXCEPT CND)	R112	1-216-851-11	METAL CHIP 330K 5% 1/10W	
C515	1-107-826-11	CERAMIC CHIP 0.1uF	10% 16V	R113	1-216-841-11	METAL CHIP 47K 5% 1/10W	
C518	1-107-826-11	CERAMIC CHIP 0.1uF	10% 16V	R116	1-216-830-11	METAL CHIP 5.6K 5% 1/10W	
C521	1-107-826-11	CERAMIC CHIP 0.1uF	10% 16V	R117	1-216-864-11	SHORT CHIP 0 (CND)	
C536	1-107-826-11	CERAMIC CHIP 0.1uF	10% 16V (EXCEPT CND)	R118	1-216-864-11	SHORT CHIP 0 (CND)	
				R119	1-216-864-11	SHORT CHIP 0 (CND)	
				R120	1-216-864-11	SHORT CHIP 0 (EXCEPT CND)	
				R121	1-216-864-11	SHORT CHIP 0 (EXCEPT CND)	
				R122	1-216-864-11	SHORT CHIP 0	
				R124	1-216-864-11	SHORT CHIP 0 (EXCEPT CND)	
				R125	1-216-809-11	METAL CHIP 100 5% 1/10W	(EXCEPT CND)
				R126	1-216-809-11	METAL CHIP 100 5% 1/10W	(EXCEPT CND)
				R127	1-216-295-00	SHORT CHIP 0 (EXCEPT CND)	
				R128	1-216-813-11	METAL CHIP 220 5% 1/10W	
				R130	1-216-845-11	METAL CHIP 100K 5% 1/10W	
				R131	1-216-833-11	METAL CHIP 10K 5% 1/10W	
				R133	1-216-833-11	METAL CHIP 10K 5% 1/10W	
				R134	1-216-857-11	METAL CHIP 1M 5% 1/10W	
				R135	1-216-821-11	METAL CHIP 1K 5% 1/10W	
				R136	1-216-295-00	SHORT CHIP 0	
				R137	1-216-857-11	METAL CHIP 1M 5% 1/10W	
				R138	1-216-857-11	METAL CHIP 1M 5% 1/10W	
				R139	1-216-809-11	METAL CHIP 100 5% 1/10W	
				R140	1-216-809-11	METAL CHIP 100 5% 1/10W	(EXCEPT CND)
				R141	1-216-809-11	METAL CHIP 100 5% 1/10W	(EXCEPT CND)
				R142	1-216-805-11	METAL CHIP 47 5% 1/10W	
				R143	1-216-845-11	METAL CHIP 100K 5% 1/10W	
				R144	1-216-845-11	METAL CHIP 100K 5% 1/10W	
				R145	1-216-845-11	METAL CHIP 100K 5% 1/10W	
				R146	1-216-845-11	METAL CHIP 100K 5% 1/10W	
				R147	1-216-833-11	METAL CHIP 10K 5% 1/10W	
IC101	6-712-082-01	IC TC94A70FG-101					
IC102	6-714-504-01	IC MM3404A15URE					
IC201	6-703-636-01	IC NJM13403V (TE2)					

HCD-MX500i/MX550i

BD96/BD96U

Ref. No.	Part No.	Description	Remark	Ref. No.	Part No.	Description	Remark
R148	1-216-833-11	METAL CHIP	10K 5% 1/10W (CND)	R408	1-216-845-11	METAL CHIP	100K 5% 1/10W (EXCEPT CND)
R149	1-216-845-11	METAL CHIP	100K 5% 1/10W	R409	1-216-833-11	METAL CHIP	10K 5% 1/10W (EXCEPT CND)
R150	1-216-845-11	METAL CHIP	100K 5% 1/10W	R410	1-216-864-11	SHORT CHIP	0 (EXCEPT CND)
R151	1-216-809-11	METAL CHIP	100 5% 1/10W	R411	1-216-829-11	METAL CHIP	4.7K 5% 1/10W (EXCEPT CND)
R152	1-216-864-11	SHORT CHIP	0 (EXCEPT CND)	R412	1-216-829-11	METAL CHIP	4.7K 5% 1/10W (EXCEPT CND)
R153	1-216-833-11	METAL CHIP	10K 5% 1/10W (CND)	R413	1-216-802-11	METAL CHIP	27 5% 1/10W (EXCEPT CND)
R154	1-216-809-11	METAL CHIP	100 5% 1/10W	R414	1-216-802-11	METAL CHIP	27 5% 1/10W (EXCEPT CND)
R155	1-216-809-11	METAL CHIP	100 5% 1/10W	R415	1-216-833-11	METAL CHIP	10K 5% 1/10W (EXCEPT CND)
R156	1-216-809-11	METAL CHIP	100 5% 1/10W	R416	1-216-809-11	METAL CHIP	100 5% 1/10W (EXCEPT CND)
R157	1-216-809-11	METAL CHIP	100 5% 1/10W	R418	1-216-809-11	METAL CHIP	100 5% 1/10W (EXCEPT CND)
R158	1-216-809-11	METAL CHIP	100 5% 1/10W	R419	1-216-864-11	SHORT CHIP	0 (EXCEPT CND)
R159	1-216-809-11	METAL CHIP	100 5% 1/10W	R420	1-216-809-11	METAL CHIP	100 5% 1/10W (EXCEPT CND)
R201	1-218-446-11	METAL CHIP	1 5% 1/10W	R421	1-216-829-11	METAL CHIP	4.7K 5% 1/10W (EXCEPT CND)
R202	1-216-791-11	METAL CHIP	3.3 5% 1/10W	R422	1-216-833-11	METAL CHIP	10K 5% 1/10W (EXCEPT CND)
R203	1-216-864-11	SHORT CHIP	0	R425	1-216-845-11	METAL CHIP	100K 5% 1/10W (EXCEPT CND)
R204	1-216-845-11	METAL CHIP	100K 5% 1/10W	R430	1-216-829-11	METAL CHIP	4.7K 5% 1/10W (EXCEPT CND)
R205	1-216-809-11	METAL CHIP	100 5% 1/10W	R431	1-216-829-11	METAL CHIP	4.7K 5% 1/10W (EXCEPT CND)
R206	1-218-871-11	METAL CHIP	10K 0.5% 1/10W	R432	1-216-845-11	METAL CHIP	100K 5% 1/10W (EXCEPT CND)
R207	1-218-871-11	METAL CHIP	10K 0.5% 1/10W	R433	1-216-829-11	METAL CHIP	4.7K 5% 1/10W (EXCEPT CND)
R208	1-218-871-11	METAL CHIP	10K 0.5% 1/10W	R434	1-216-845-11	METAL CHIP	100K 5% 1/10W (EXCEPT CND)
R209	1-218-871-11	METAL CHIP	10K 0.5% 1/10W	R435	1-216-829-11	METAL CHIP	4.7K 5% 1/10W (EXCEPT CND)
R210	1-218-871-11	METAL CHIP	10K 0.5% 1/10W	R436	1-216-845-11	METAL CHIP	100K 5% 1/10W (EXCEPT CND)
R211	1-216-821-11	METAL CHIP	1K 5% 1/10W	R437	1-216-829-11	METAL CHIP	4.7K 5% 1/10W (EXCEPT CND)
R212	1-216-821-11	METAL CHIP	1K 5% 1/10W	R438	1-216-845-11	METAL CHIP	100K 5% 1/10W (EXCEPT CND)
R213	1-218-871-11	METAL CHIP	10K 0.5% 1/10W	R439	1-216-829-11	METAL CHIP	4.7K 5% 1/10W (EXCEPT CND)
R214	1-218-871-11	METAL CHIP	10K 0.5% 1/10W	R440	1-216-833-11	METAL CHIP	10K 5% 1/10W (EXCEPT CND)
R215	1-218-871-11	METAL CHIP	10K 0.5% 1/10W	R441	1-216-833-11	METAL CHIP	10K 5% 1/10W (EXCEPT CND)
R216	1-218-871-11	METAL CHIP	10K 0.5% 1/10W	R442	1-216-809-11	METAL CHIP	100 5% 1/10W (EXCEPT CND)
R217	1-218-871-11	METAL CHIP	10K 0.5% 1/10W	R443	1-216-809-11	METAL CHIP	100 5% 1/10W (EXCEPT CND)
R218	1-218-871-11	METAL CHIP	10K 0.5% 1/10W	R444	1-216-809-11	METAL CHIP	100 5% 1/10W (EXCEPT CND)
R219	1-218-871-11	METAL CHIP	10K 0.5% 1/10W	R445	1-216-809-11	METAL CHIP	100 5% 1/10W (EXCEPT CND)
R220	1-218-871-11	METAL CHIP	10K 0.5% 1/10W	R446	1-216-809-11	METAL CHIP	100 5% 1/10W (EXCEPT CND)
R221	1-218-871-11	METAL CHIP	10K 0.5% 1/10W	R447	1-216-809-11	METAL CHIP	100 5% 1/10W (EXCEPT CND)
R222	1-218-871-11	METAL CHIP	10K 0.5% 1/10W	R448	1-216-809-11	METAL CHIP	100 5% 1/10W (EXCEPT CND)
R223	1-218-871-11	METAL CHIP	10K 0.5% 1/10W				
R224	1-218-871-11	METAL CHIP	10K 0.5% 1/10W				
R225	1-218-871-11	METAL CHIP	10K 0.5% 1/10W				
R226	1-218-871-11	METAL CHIP	10K 0.5% 1/10W				
R227	1-218-871-11	METAL CHIP	10K 0.5% 1/10W				
R228	1-218-871-11	METAL CHIP	10K 0.5% 1/10W				
R229	1-218-871-11	METAL CHIP	10K 0.5% 1/10W				
R230	1-218-871-11	METAL CHIP	10K 0.5% 1/10W				
R231	1-218-871-11	METAL CHIP	10K 0.5% 1/10W				
R302	1-216-833-11	METAL CHIP	10K 5% 1/10W				
R305	1-216-835-11	METAL CHIP	15K 5% 1/10W				
R306	1-216-864-11	SHORT CHIP	0				
R308	1-216-840-11	METAL CHIP	39K 5% 1/10W				
R311	1-216-833-11	METAL CHIP	10K 5% 1/10W				
R314	1-216-864-11	SHORT CHIP	0				
R316	1-216-841-11	METAL CHIP	47K 5% 1/10W				
R401	1-216-864-11	SHORT CHIP	0 (EXCEPT CND)				
R402	1-216-864-11	SHORT CHIP	0 (EXCEPT CND)				
R403	1-216-835-11	METAL CHIP	15K 5% 1/10W (EXCEPT CND)				
R404	1-216-835-11	METAL CHIP	15K 5% 1/10W (EXCEPT CND)				
R407	1-216-833-11	METAL CHIP	10K 5% 1/10W (EXCEPT CND)				

Ref. No.	Part No.	Description	Remark	Ref. No.	Part No.	Description	Remark
R449	1-216-805-11	METAL CHIP	47 5% 1/10W (EXCEPT CND)	R512	1-216-809-11	METAL CHIP	100 5% 1/10W
R450	1-216-805-11	METAL CHIP	47 5% 1/10W (EXCEPT CND)	R513	1-216-809-11	METAL CHIP	100 5% 1/10W
R451	1-216-805-11	METAL CHIP	47 5% 1/10W (EXCEPT CND)	R514	1-216-809-11	METAL CHIP	100 5% 1/10W
R452	1-216-805-11	METAL CHIP	47 5% 1/10W (EXCEPT CND)	R515	1-216-295-00	SHORT CHIP	0 (EXCEPT CND)
R453	1-216-805-11	METAL CHIP	47 5% 1/10W (EXCEPT CND)	R516	1-216-809-11	METAL CHIP	100 5% 1/10W (EXCEPT CND)
R454	1-216-805-11	METAL CHIP	47 5% 1/10W (EXCEPT CND)	R518	1-216-809-11	METAL CHIP	100 5% 1/10W (EXCEPT CND)
R455	1-216-805-11	METAL CHIP	47 5% 1/10W (EXCEPT CND)	R519	1-216-809-11	METAL CHIP	100 5% 1/10W (EXCEPT CND)
R456	1-216-805-11	METAL CHIP	47 5% 1/10W (EXCEPT CND)	R520	1-216-809-11	METAL CHIP	100 5% 1/10W (EXCEPT CND)
R457	1-216-809-11	METAL CHIP	100 5% 1/10W (EXCEPT CND)	R521	1-216-809-11	METAL CHIP	100 5% 1/10W (EXCEPT CND)
R458	1-216-809-11	METAL CHIP	100 5% 1/10W (EXCEPT CND)	< VIBRATOR >			
R459	1-216-295-00	SHORT CHIP	0 (EXCEPT CND)	X101	1-795-101-21	VIBRATOR, CERAMIC (16.934MHz)	
R463	1-216-805-11	METAL CHIP	47 5% 1/10W (EXCEPT CND)	X401	1-814-400-11	QUARTZ CRYSTAL UNITS (9MHz)	(EXCEPT CND)
R464	1-216-805-11	METAL CHIP	47 5% 1/10W (EXCEPT CND)	*****			
R465	1-216-805-11	METAL CHIP	47 5% 1/10W (EXCEPT CND)	DAB BOARD (MX550i)			
R466	1-216-805-11	METAL CHIP	47 5% 1/10W (EXCEPT CND)	*****			
R467	1-216-805-11	METAL CHIP	47 5% 1/10W (EXCEPT CND)	< CAPACITOR >			
R468	1-216-805-11	METAL CHIP	47 5% 1/10W (EXCEPT CND)	C672	1-127-715-11	CERAMIC CHIP	0.22uF 10% 16V
R469	1-216-805-11	METAL CHIP	47 5% 1/10W (EXCEPT CND)	C673	1-162-970-11	CERAMIC CHIP	0.01uF 10% 25V
R470	1-216-805-11	METAL CHIP	47 5% 1/10W (EXCEPT CND)	C674	1-165-908-11	CERAMIC CHIP	1uF 10% 10V
R471	1-216-833-11	METAL CHIP	10K 5% 1/10W (EXCEPT CND)	C675	1-107-826-11	CERAMIC CHIP	0.1uF 10% 16V
R472	1-216-864-11	SHORT CHIP	0 (CND)	C677	1-165-908-11	CERAMIC CHIP	1uF 10% 10V
R473	1-216-864-11	SHORT CHIP	0 (CND)	C678	1-165-908-11	CERAMIC CHIP	1uF 10% 10V
R474	1-216-864-11	SHORT CHIP	0 (CND)	C679	1-165-908-11	CERAMIC CHIP	1uF 10% 10V
R475	1-216-864-11	SHORT CHIP	0 (CND)	C681	1-107-826-11	CERAMIC CHIP	0.1uF 10% 16V
R476	1-216-864-11	SHORT CHIP	0 (CND)	C682	1-124-584-00	ELECT	100uF 20% 6.3V
R477	1-216-864-11	SHORT CHIP	0 (CND)	C683	1-162-915-11	CERAMIC CHIP	10PF 0.5PF 50V
R478	1-216-864-11	SHORT CHIP	0 (CND)	C684	1-162-923-11	CERAMIC CHIP	47PF 5% 50V
R479	1-216-821-11	METAL CHIP	1K 5% 1/10W (EXCEPT CND)	C685	1-162-915-11	CERAMIC CHIP	10PF 0.5PF 50V
R480	1-216-833-11	METAL CHIP	10K 5% 1/10W (EXCEPT CND)	C686	1-162-923-11	CERAMIC CHIP	47PF 5% 50V
R481	1-216-845-11	METAL CHIP	100K 5% 1/10W (EXCEPT CND)	C688	1-162-915-11	CERAMIC CHIP	10PF 0.5PF 50V
R501	1-216-295-00	SHORT CHIP	0	C689	1-162-923-11	CERAMIC CHIP	47PF 5% 50V
R502	1-216-295-00	SHORT CHIP	0	C690	1-162-915-11	CERAMIC CHIP	10PF 0.5PF 50V
R503	1-216-295-00	SHORT CHIP	0	C691	1-162-923-11	CERAMIC CHIP	47PF 5% 50V
R504	1-216-809-11	METAL CHIP	100 5% 1/10W	< CONNECTOR >			
R505	1-216-809-11	METAL CHIP	100 5% 1/10W	CN671	1-779-277-11	CONNECTOR, FFC (LIF (NON-ZIF)) 9P	
R506	1-216-809-11	METAL CHIP	100 5% 1/10W	CN672	1-821-719-11	P.W.B CONNECTOR 30P	
R507	1-216-809-11	METAL CHIP	100 5% 1/10W	< JUMPER RESISTOR >			
R508	1-216-809-11	METAL CHIP	100 5% 1/10W	FB671	1-216-864-11	SHORT CHIP	0
R509	1-216-809-11	METAL CHIP	100 5% 1/10W	< IC >			
R510	1-216-809-11	METAL CHIP	100 5% 1/10W	IC671	6-702-302-01	IC TK11133CSCL-G	
R511	1-216-809-11	METAL CHIP	100 5% 1/10W	IC672	6-712-613-01	IC SI-3010KM-TLS	
				< RESISTOR >			
				R672	1-216-833-11	METAL CHIP	10K 5% 1/10W
				R673	1-216-809-11	METAL CHIP	100 5% 1/10W
				R675	1-216-841-11	METAL CHIP	47K 5% 1/10W
				R676	1-216-821-11	METAL CHIP	1K 5% 1/10W
				R677	1-216-833-11	METAL CHIP	10K 5% 1/10W
				R678	1-216-821-11	METAL CHIP	1K 5% 1/10W

HCD-MX500i/MX550i

DAB **FL** **IP**

Ref. No.	Part No.	Description	Remark	Ref. No.	Part No.	Description	Remark
R679	1-216-833-11	METAL CHIP 10K 5%	1/10W	R626	1-216-809-11	METAL CHIP 100 5%	1/10W
R680	1-216-809-11	METAL CHIP 100 5%	1/10W	R627	1-216-809-11	METAL CHIP 100 5%	1/10W
R681	1-216-864-11	SHORT CHIP 0		R628	1-216-827-11	METAL CHIP 3.3K 5%	1/10W
*****				R629	1-216-821-11	METAL CHIP 1K 5%	1/10W
		FL BOARD		R630	1-216-864-11	SHORT CHIP 0	
		*****		R631	1-216-864-11	SHORT CHIP 0	
		< CAPACITOR >		R632	1-216-864-11	SHORT CHIP 0	
C621	1-124-234-00	ELECT 22uF 20%	16V	R633	1-216-837-11	METAL CHIP 22K 5%	1/10W
C623	1-136-157-00	FILM 0.022uF 5%	50V	R634	1-216-837-11	METAL CHIP 22K 5%	1/10W
C625	1-162-974-11	CERAMIC CHIP 0.01uF	50V	R635	1-216-805-11	METAL CHIP 47 5%	1/10W
C626	1-128-131-11	ELECT 22uF 20%	50V	R638	1-216-825-11	METAL CHIP 2.2K 5%	1/10W
C627	1-162-974-11	CERAMIC CHIP 0.01uF	50V	R639	1-216-821-11	METAL CHIP 1K 5%	1/10W
C628	1-162-974-11	CERAMIC CHIP 0.01uF	50V	R640	1-216-833-11	METAL CHIP 10K 5%	1/10W
C629	1-162-974-11	CERAMIC CHIP 0.01uF	50V	R641	1-216-829-11	METAL CHIP 4.7K 5%	1/10W
C631	1-162-923-11	CERAMIC CHIP 47PF 5%	50V	< ROTARY ENCODER >			
C632	1-162-964-11	CERAMIC CHIP 0.001uF 10%	50V	RV621	1-418-725-41	ENCODER, ROTARY (12 TYPE) (VOLUME)	
C633	1-162-927-11	CERAMIC CHIP 100PF 5%	50V	< TRANSFORMER >			
C634	1-162-927-11	CERAMIC CHIP 100PF 5%	50V	T621	1-445-890-11	TRANSFORMER, DC-DC CONVERTER	
C635	1-162-927-11	CERAMIC CHIP 100PF 5%	50V	*****			
C636	1-124-234-00	ELECT 22uF 20%	16V		A-1760-782-A	IP BOARD, COMPLETE	
C637	1-128-131-11	ELECT 22uF 20%	50V			*****	
C640	1-162-970-11	CERAMIC CHIP 0.01uF 10%	25V			< CAPACITOR >	
C641	1-107-826-11	CERAMIC CHIP 0.1uF 10%	16V	C331	1-164-870-11	CERAMIC CHIP 68PF 5%	50V
C642	1-165-908-11	CERAMIC CHIP 1uF 10%	10V	C332	1-164-854-11	CERAMIC CHIP 15PF 5%	50V
C645	1-125-972-11	ELECT 100uF 20%	16V	C333	1-164-870-11	CERAMIC CHIP 68PF 5%	50V
C646	1-127-573-11	CERAMIC CHIP 1uF 10%	16V	C334	1-164-854-11	CERAMIC CHIP 15PF 5%	50V
		< CONNECTOR >		C335	1-164-870-11	CERAMIC CHIP 68PF 5%	50V
CN621	1-779-550-21	CONNECTOR, FFC (LIF (NON-ZIF)) 13P		C336	1-164-854-11	CERAMIC CHIP 15PF 5%	50V
CN622	1-564-720-11	PIN, CONNECTOR (SMALL TYPE) 4P		C339	1-164-870-11	CERAMIC CHIP 68PF 5%	50V
		< DIODE >		C340	1-164-854-11	CERAMIC CHIP 15PF 5%	50V
D621	6-500-334-01	DIODE MC2836-T112-1		C342	1-165-989-11	CERAMIC CHIP 10uF 10%	6.3V
D622	6-500-335-01	DIODE MC2838-T112-1		C343	1-116-344-11	ELECT 330uF 20%	6.3V
D623	6-502-968-01	DIODE DZ2J062M0L				< CONNECTOR >	
		< JUMPER RESISTOR >		CN331	1-784-865-51	CONNECTOR, FFC (LIF (NON-ZIF)) 13P	
FB621	1-216-295-00	SHORT CHIP 0		CN332	1-820-701-11	PIN, CONNECTOR 30P (iPod/iPhone Dock)	
		< IC >				< RESISTOR/FERRITE BEAD >	
IC621	6-711-008-01	IC PT6302LQ-010		R331	1-218-892-11	METAL CHIP 75K 0.5%	1/10W
IC622	6-600-767-01	IC PNA4823M02S0		R332	1-208-935-11	METAL CHIP 100K 0.5%	1/16W
		< COIL >		R333	1-208-935-11	METAL CHIP 100K 0.5%	1/16W
L621	1-412-537-31	INDUCTOR 100uH		R334	1-218-892-11	METAL CHIP 75K 0.5%	1/10W
		< FLUORESCENT INDICATOR TUBE >		R335	1-208-935-11	METAL CHIP 100K 0.5%	1/16W
ND621	1-519-993-21	INDICATOR TUBE, FLUORESCENT		R336	1-208-935-11	METAL CHIP 100K 0.5%	1/16W
		< TRANSISTOR >		R337	1-216-864-11	SHORT CHIP 0	
Q621	6-550-065-01	TRANSISTOR CPH5504-TL-E		R338	1-216-864-11	SHORT CHIP 0	
Q622	8-729-620-07	TRANSISTOR 2SC3052EF-T1-LEF		R339	1-216-864-11	SHORT CHIP 0	
Q623	8-729-027-38	TRANSISTOR DTA144EKA-T146		R390	1-216-864-11	SHORT CHIP 0	
		< RESISTOR >		R391	1-400-050-11	INDUCTOR, FERRITE BEAD	
R621	1-216-789-11	METAL CHIP 2.2 5%	1/10W	R392	1-400-050-11	INDUCTOR, FERRITE BEAD	
R622	1-216-825-11	METAL CHIP 2.2K 5%	1/10W	R393	1-216-864-11	SHORT CHIP 0	
R625	1-216-833-11	METAL CHIP 10K 5%	1/10W	R394	1-216-864-11	SHORT CHIP 0	
				R395	1-216-864-11	SHORT CHIP 0	
				R396	1-216-864-11	SHORT CHIP 0	
				R397	1-216-864-11	SHORT CHIP 0	
				R398	1-216-864-11	SHORT CHIP 0	

Ref. No.	Part No.	Description	Remark
R399	1-216-864-11	SHORT CHIP 0	

		JACK BOARD	

		< CAPACITOR >	
C155	1-162-923-11	CERAMIC CHIP 47PF 5% 50V	
C156	1-162-915-11	CERAMIC CHIP 10PF 0.5PF 50V	
C255	1-162-923-11	CERAMIC CHIP 47PF 5% 50V	
C256	1-162-915-11	CERAMIC CHIP 10PF 0.5PF 50V	
C302	1-164-360-11	CERAMIC CHIP 0.1uF 16V	
		< DIODE >	
D302	6-500-848-01	DIODE MC2840-T112-1	
		< JACK >	
J302	1-815-629-21	JACK (AUDIO IN)	
		< JUMPER RESISTOR >	
JR301	1-216-864-11	SHORT CHIP 0	
		< RESISTOR/FERRITE BEAD >	
R160	1-216-821-11	METAL CHIP 1K 5% 1/10W	
R260	1-216-821-11	METAL CHIP 1K 5% 1/10W	
R302	1-414-385-21	INDUCTOR, FERRITE BEAD	
R303	1-216-864-11	SHORT CHIP 0	

		KEY BOARD	

		< LED >	
D624	6-501-483-01	LED SLR-325VCT31P (STANDBY)	
		< RESISTOR >	
R637	1-216-817-11	METAL CHIP 470 5% 1/10W	
R642	1-216-821-11	METAL CHIP 1K 5% 1/10W	
R643	1-216-825-11	METAL CHIP 2.2K 5% 1/10W	
R644	1-216-825-11	METAL CHIP 2.2K 5% 1/10W	
R645	1-216-829-11	METAL CHIP 4.7K 5% 1/10W	
R646	1-216-833-11	METAL CHIP 10K 5% 1/10W	
R647	1-216-821-11	METAL CHIP 1K 5% 1/10W	
R648	1-216-825-11	METAL CHIP 2.2K 5% 1/10W	
R649	1-216-825-11	METAL CHIP 2.2K 5% 1/10W	
R650	1-216-829-11	METAL CHIP 4.7K 5% 1/10W	
R651	1-216-833-11	METAL CHIP 10K 5% 1/10W	
		< SWITCH >	
S621	1-762-875-21	SWITCH, KEYBOARD (I/C)	(MX500i: CND, AEP/MX550i)
S621	1-771-410-21	SWITCH, TACTILE (I/C) (CH, SP)	
S622	1-762-875-21	SWITCH, KEYBOARD (FUNCTION)	(MX500i: CND, AEP/MX550i)
S622	1-771-410-21	SWITCH, TACTILE (FUNCTION) (CH, SP)	
S623	1-762-875-21	SWITCH, KEYBOARD (I/II)	(MX500i: CND, AEP/MX550i)
S623	1-771-410-21	SWITCH, TACTILE (I/II) (CH, SP)	
S624	1-762-875-21	SWITCH, KEYBOARD (I/II)	(MX500i: CND, AEP/MX550i)
S624	1-771-410-21	SWITCH, TACTILE (I/II) (CH, SP)	

Ref. No.	Part No.	Description	Remark
S625	1-762-875-21	SWITCH, KEYBOARD (I/C) TUNE -)	(MX500i: CND, AEP/MX550i)
S625	1-771-410-21	SWITCH, TACTILE (I/C) TUNE -) (CH, SP)	
S626	1-762-875-21	SWITCH, KEYBOARD (I/II) TUNE +)	(MX500i: CND, AEP/MX550i)
S626	1-771-410-21	SWITCH, TACTILE (I/II) TUNE +) (CH, SP)	
S627	1-762-875-21	SWITCH, KEYBOARD (DSGX)	(MX500i: CND, AEP/MX550i)
S627	1-771-410-21	SWITCH, TACTILE (DSGX) (CH, SP)	
S628	1-762-875-21	SWITCH, KEYBOARD (TOOL MENU)	(MX500i: CND, AEP/MX550i)
S628	1-771-410-21	SWITCH, TACTILE (TOOL MENU) (CH, SP)	
S629	1-762-875-21	SWITCH, KEYBOARD (I/C + A)	(MX500i: CND, AEP/MX550i)
S629	1-771-410-21	SWITCH, TACTILE (I/C + A) (CH, SP)	
S630	1-762-875-21	SWITCH, KEYBOARD (ENTER)	(MX500i: CND, AEP/MX550i)
S630	1-771-410-21	SWITCH, TACTILE (ENTER) (CH, SP)	
S631	1-762-875-21	SWITCH, KEYBOARD (I/C -)	(MX500i: CND, AEP/MX550i)
S631	1-771-410-21	SWITCH, TACTILE (I/C -) (CH, SP)	
S632	1-762-875-21	SWITCH, KEYBOARD (I/II)	(MX500i: CND, AEP/MX550i)
S632	1-771-410-21	SWITCH, TACTILE (I/II) (CH, SP)	

A-1760-771-A		MAIN BOARD, COMPLETE (MX500i: AEP)	
A-1760-784-A		MAIN BOARD, COMPLETE (CND)	
A-1760-905-A		MAIN BOARD, COMPLETE (MX550i)	
A-1783-490-A		MAIN BOARD, COMPLETE (CH, SP)	*****
		< CAPACITOR >	
C101	1-165-908-11	CERAMIC CHIP 1uF 10% 10V	
C104	1-165-908-11	CERAMIC CHIP 1uF 10% 10V	
C105	1-164-230-11	CERAMIC CHIP 220PF 5% 50V	(MX550i)
C106	1-164-230-11	CERAMIC CHIP 220PF 5% 50V	(MX550i)
C107	1-124-779-00	ELECT CHIP 10uF 20% 16V	
C108	1-124-779-00	ELECT CHIP 10uF 20% 16V	
C109	1-126-193-11	ELECT CHIP 1uF 20% 50V	(MX550i)
C117	1-124-779-00	ELECT CHIP 10uF 20% 16V	
C118	1-164-173-11	CERAMIC CHIP 0.0039uF 10% 50V	
C120	1-136-498-81	FILM 0.12uF 5% 50V	
C121	1-136-498-81	FILM 0.12uF 5% 50V	
C124	1-124-779-00	ELECT CHIP 10uF 20% 16V	
C125	1-126-960-11	ELECT 1uF 20% 50V	
C126	1-126-193-11	ELECT CHIP 1uF 20% 50V	
C129	1-164-230-11	CERAMIC CHIP 220PF 5% 50V	
C130	1-164-230-11	CERAMIC CHIP 220PF 5% 50V	
C140	1-162-970-11	CERAMIC CHIP 0.01uF 10% 25V	
C141	1-164-230-11	CERAMIC CHIP 220PF 5% 50V	(MX550i)
C143	1-126-193-11	ELECT CHIP 1uF 20% 50V	(MX550i)
C144	1-126-193-11	ELECT CHIP 1uF 20% 50V	(MX550i)
C146	1-126-193-11	ELECT CHIP 1uF 20% 50V	(MX550i)
C161	1-164-854-11	CERAMIC CHIP 15PF 5% 50V	
C162	1-164-870-11	CERAMIC CHIP 68PF 5% 50V	
C163	1-164-854-11	CERAMIC CHIP 15PF 5% 50V	

HCD-MX500i/MX550i

MAIN

Ref. No.	Part No.	Description	Remark	Ref. No.	Part No.	Description	Remark
C164	1-164-870-11	CERAMIC CHIP 68PF	5% 50V	C252	1-107-826-11	CERAMIC CHIP 0.1uF	10% 16V (MX550i)
C165	1-164-854-11	CERAMIC CHIP 15PF	5% 50V	C254	1-165-908-11	CERAMIC CHIP 1uF	10% 10V (MX550i)
C166	1-164-870-11	CERAMIC CHIP 68PF	5% 50V	C261	1-164-854-11	CERAMIC CHIP 15PF	5% 50V
C167	1-164-854-11	CERAMIC CHIP 15PF	5% 50V (MX550i)	C262	1-164-870-11	CERAMIC CHIP 68PF	5% 50V
C168	1-164-870-11	CERAMIC CHIP 68PF	5% 50V (MX550i)	C263	1-164-854-11	CERAMIC CHIP 15PF	5% 50V
C169	1-164-854-11	CERAMIC CHIP 15PF	5% 50V	C264	1-164-870-11	CERAMIC CHIP 68PF	5% 50V
C170	1-164-870-11	CERAMIC CHIP 68PF	5% 50V	C265	1-164-854-11	CERAMIC CHIP 15PF	5% 50V
C171	1-164-854-11	CERAMIC CHIP 15PF	5% 50V	C266	1-164-870-11	CERAMIC CHIP 68PF	5% 50V
C172	1-164-870-11	CERAMIC CHIP 68PF	5% 50V	C267	1-164-854-11	CERAMIC CHIP 15PF	5% 50V (MX550i)
C173	1-164-854-11	CERAMIC CHIP 15PF	5% 50V	C268	1-164-870-11	CERAMIC CHIP 68PF	5% 50V (MX550i)
C174	1-164-870-11	CERAMIC CHIP 68PF	5% 50V	C269	1-164-854-11	CERAMIC CHIP 15PF	5% 50V
C181	1-164-854-11	CERAMIC CHIP 15PF	5% 50V	C270	1-164-870-11	CERAMIC CHIP 68PF	5% 50V
C182	1-164-870-11	CERAMIC CHIP 68PF	5% 50V	C271	1-164-854-11	CERAMIC CHIP 15PF	5% 50V
C183	1-164-854-11	CERAMIC CHIP 15PF	5% 50V	C272	1-164-870-11	CERAMIC CHIP 68PF	5% 50V
C184	1-164-870-11	CERAMIC CHIP 68PF	5% 50V	C273	1-164-854-11	CERAMIC CHIP 15PF	5% 50V
C185	1-164-854-11	CERAMIC CHIP 15PF	5% 50V	C274	1-164-870-11	CERAMIC CHIP 68PF	5% 50V
C186	1-164-870-11	CERAMIC CHIP 68PF	5% 50V	C281	1-164-854-11	CERAMIC CHIP 15PF	5% 50V
C187	1-164-854-11	CERAMIC CHIP 15PF	5% 50V (MX550i)	C282	1-164-870-11	CERAMIC CHIP 68PF	5% 50V
C188	1-164-870-11	CERAMIC CHIP 68PF	5% 50V (MX550i)	C283	1-164-854-11	CERAMIC CHIP 15PF	5% 50V
C189	1-164-854-11	CERAMIC CHIP 15PF	5% 50V (MX550i)	C284	1-164-870-11	CERAMIC CHIP 68PF	5% 50V
C190	1-164-870-11	CERAMIC CHIP 68PF	5% 50V (MX550i)	C285	1-164-854-11	CERAMIC CHIP 15PF	5% 50V
C191	1-164-854-11	CERAMIC CHIP 15PF	5% 50V (MX550i)	C286	1-164-870-11	CERAMIC CHIP 68PF	5% 50V
C192	1-164-870-11	CERAMIC CHIP 68PF	5% 50V (MX550i)	C287	1-164-854-11	CERAMIC CHIP 15PF	5% 50V (MX550i)
C193	1-164-854-11	CERAMIC CHIP 15PF	5% 50V	C288	1-164-870-11	CERAMIC CHIP 68PF	5% 50V (MX550i)
C194	1-164-870-11	CERAMIC CHIP 68PF	5% 50V	C289	1-164-854-11	CERAMIC CHIP 15PF	5% 50V (MX550i)
C201	1-165-908-11	CERAMIC CHIP 1uF	10% 10V	C290	1-164-870-11	CERAMIC CHIP 68PF	5% 50V (MX550i)
C204	1-165-908-11	CERAMIC CHIP 1uF	10% 10V	C291	1-164-854-11	CERAMIC CHIP 15PF	5% 50V (MX550i)
C205	1-164-230-11	CERAMIC CHIP 220PF	5% 50V (MX550i)	C292	1-164-870-11	CERAMIC CHIP 68PF	5% 50V (MX550i)
C206	1-164-230-11	CERAMIC CHIP 220PF	5% 50V (MX550i)	C293	1-164-854-11	CERAMIC CHIP 15PF	5% 50V
C207	1-124-779-00	ELECT CHIP 10uF	20% 16V	C294	1-164-870-11	CERAMIC CHIP 68PF	5% 50V
C208	1-124-779-00	ELECT CHIP 10uF	20% 16V	C401	1-165-908-11	CERAMIC CHIP 1uF	10% 10V
C209	1-126-193-11	ELECT CHIP 1uF	20% 50V (MX550i)	C402	1-165-908-11	CERAMIC CHIP 1uF	10% 10V
C217	1-124-779-00	ELECT CHIP 10uF	20% 16V	C403	1-162-970-11	CERAMIC CHIP 0.01uF	10% 25V
C218	1-164-173-11	CERAMIC CHIP 0.0039uF	10% 50V	C406	1-124-779-00	ELECT CHIP 10uF	20% 16V
C220	1-136-498-81	FILM 0.12uF	5% 50V	C408	1-107-826-11	CERAMIC CHIP 0.1uF	10% 16V
C221	1-136-498-81	FILM 0.12uF	5% 50V	C409	1-107-826-11	CERAMIC CHIP 0.1uF	10% 16V
C224	1-124-779-00	ELECT CHIP 10uF	20% 16V	C412	1-107-826-11	CERAMIC CHIP 0.1uF	10% 16V
C225	1-126-960-11	ELECT 1uF	20% 50V	C416	1-107-826-11	CERAMIC CHIP 0.1uF	10% 16V
C226	1-126-193-11	ELECT CHIP 1uF	20% 50V	C418	1-125-837-11	CERAMIC CHIP 1uF	10% 6.3V
C229	1-164-230-11	CERAMIC CHIP 220PF	5% 50V	C419	1-125-837-11	CERAMIC CHIP 1uF	10% 6.3V
C230	1-164-230-11	CERAMIC CHIP 220PF	5% 50V	C420	1-162-927-11	CERAMIC CHIP 100PF	5% 50V
C240	1-162-970-11	CERAMIC CHIP 0.01uF	10% 25V	C421	1-162-966-11	CERAMIC CHIP 0.0022uF	10% 50V
C241	1-164-230-11	CERAMIC CHIP 220PF	5% 50V (MX550i)	C422	1-125-837-11	CERAMIC CHIP 1uF	10% 6.3V
C242	1-126-193-11	ELECT CHIP 1uF	20% 50V (MX550i)	C423	1-165-908-11	CERAMIC CHIP 1uF	10% 10V
C246	1-126-193-11	ELECT CHIP 1uF	20% 50V (MX550i)	C424	1-162-964-11	CERAMIC CHIP 0.001uF	10% 50V
C247	1-126-193-11	ELECT CHIP 1uF	20% 50V (MX550i)	C425	1-165-908-11	CERAMIC CHIP 1uF	10% 10V
				C466	1-165-908-11	CERAMIC CHIP 1uF	10% 10V
				C467	1-162-927-11	CERAMIC CHIP 100PF	5% 50V
				C468	1-162-927-11	CERAMIC CHIP 100PF	5% 50V
				C469	1-127-573-11	CERAMIC CHIP 1uF	10% 16V
				C470	1-165-908-11	CERAMIC CHIP 1uF	10% 10V
				C471	1-107-826-11	CERAMIC CHIP 0.1uF	10% 16V

Ref. No.	Part No.	Description	Remark	Ref. No.	Part No.	Description	Remark
C472	1-162-970-11	CERAMIC CHIP 0.01uF	10% 25V	C536	1-165-908-11	CERAMIC CHIP 1uF	10% 10V
C473	1-164-854-11	CERAMIC CHIP 15PF	5% 50V	C540	1-107-826-11	CERAMIC CHIP 0.1uF	10% 16V
C474	1-164-870-11	CERAMIC CHIP 68PF	5% 50V	C543	1-162-927-11	CERAMIC CHIP 100PF	5% 50V (EXCEPT CND)
C475	1-164-854-11	CERAMIC CHIP 15PF	5% 50V (EXCEPT CND)	C544	1-162-927-11	CERAMIC CHIP 100PF	5% 50V (EXCEPT CND)
C476	1-164-870-11	CERAMIC CHIP 68PF	5% 50V (EXCEPT CND)	C545	1-162-927-11	CERAMIC CHIP 100PF	5% 50V (EXCEPT CND)
C477	1-162-970-11	CERAMIC CHIP 0.01uF	10% 25V	C546	1-162-927-11	CERAMIC CHIP 100PF	5% 50V (EXCEPT CND)
C478	1-107-826-11	CERAMIC CHIP 0.1uF	10% 16V	C547	1-124-779-00	ELECT CHIP 10uF	20% 16V
C479	1-107-826-11	CERAMIC CHIP 0.1uF	10% 16V	C551	1-107-826-11	CERAMIC CHIP 0.1uF	10% 16V
C480	1-107-826-11	CERAMIC CHIP 0.1uF	10% 16V	C563	1-100-567-81	CERAMIC CHIP 0.01uF	10% 25V
C481	1-164-854-11	CERAMIC CHIP 15PF	5% 50V	C564	1-165-908-11	CERAMIC CHIP 1uF	10% 10V
C482	1-164-870-11	CERAMIC CHIP 68PF	5% 50V	C565	1-107-826-11	CERAMIC CHIP 0.1uF	10% 16V
C483	1-164-854-11	CERAMIC CHIP 15PF	5% 50V	C566	1-107-826-11	CERAMIC CHIP 0.1uF	10% 16V
C484	1-164-870-11	CERAMIC CHIP 68PF	5% 50V	C567	1-104-658-91	ELECT 100uF	20% 10V
C485	1-164-854-11	CERAMIC CHIP 15PF	5% 50V	C568	1-126-933-11	ELECT 100uF	20% 16V
C486	1-164-870-11	CERAMIC CHIP 68PF	5% 50V	C569	1-162-970-11	CERAMIC CHIP 0.01uF	10% 25V
C487	1-164-854-11	CERAMIC CHIP 15PF	5% 50V	C570	1-162-970-11	CERAMIC CHIP 0.01uF	10% 25V (EXCEPT CND)
C488	1-164-870-11	CERAMIC CHIP 68PF	5% 50V	C571	1-125-889-11	CERAMIC CHIP 2.2uF	10% 10V (EXCEPT CND)
C489	1-164-854-11	CERAMIC CHIP 15PF	5% 50V	C572	1-165-908-11	CERAMIC CHIP 1uF	10% 10V (EXCEPT CND)
C490	1-164-870-11	CERAMIC CHIP 68PF	5% 50V	C574	1-125-889-11	CERAMIC CHIP 2.2uF	10% 10V
C491	1-164-854-11	CERAMIC CHIP 15PF	5% 50V	C575	1-165-908-11	CERAMIC CHIP 1uF	10% 10V
C492	1-164-870-11	CERAMIC CHIP 68PF	5% 50V	C577	1-124-779-00	ELECT CHIP 10uF	20% 16V
C493	1-164-854-11	CERAMIC CHIP 15PF	5% 50V	C578	1-126-933-11	ELECT 100uF	20% 16V (EXCEPT CND)
C494	1-164-870-11	CERAMIC CHIP 68PF	5% 50V	C579	1-128-995-21	ELECT CHIP 100uF	20% 10V
C495	1-165-908-11	CERAMIC CHIP 1uF	10% 10V (MX550i)	C580	1-126-933-11	ELECT 100uF	20% 16V
C498	1-107-826-11	CERAMIC CHIP 0.1uF	10% 16V	C581	1-107-826-11	CERAMIC CHIP 0.1uF	10% 16V (EXCEPT CND)
C499	1-107-826-11	CERAMIC CHIP 0.1uF	10% 16V	C582	1-107-826-11	CERAMIC CHIP 0.1uF	10% 16V
C500	1-107-826-11	CERAMIC CHIP 0.1uF	10% 16V	C584	1-164-854-11	CERAMIC CHIP 15PF	5% 50V
C501	1-117-748-81	CERAMIC CHIP 10PF	0.1PF 16V	C585	1-164-870-11	CERAMIC CHIP 68PF	5% 50V
C502	1-117-748-81	CERAMIC CHIP 10PF	0.1PF 16V	C586	1-164-854-11	CERAMIC CHIP 15PF	5% 50V
C503	1-128-994-21	ELECT CHIP 47uF	20% 10V	C587	1-164-870-11	CERAMIC CHIP 68PF	5% 50V
C504	1-107-826-11	CERAMIC CHIP 0.1uF	10% 16V	C590	1-164-854-11	CERAMIC CHIP 15PF	5% 50V
C505	1-107-826-11	CERAMIC CHIP 0.1uF	10% 16V	C591	1-164-870-11	CERAMIC CHIP 68PF	5% 50V
C506	1-128-398-11	ELECT CHIP 220uF	20% 16V	C592	1-164-854-11	CERAMIC CHIP 15PF	5% 50V (MX550i)
C509	1-165-908-11	CERAMIC CHIP 1uF	10% 10V	C593	1-164-870-11	CERAMIC CHIP 68PF	5% 50V (MX550i)
C510	1-162-918-11	CERAMIC CHIP 18PF	5% 50V	C594	1-164-854-11	CERAMIC CHIP 15PF	5% 50V
C511	1-162-918-11	CERAMIC CHIP 18PF	5% 50V	C595	1-164-870-11	CERAMIC CHIP 68PF	5% 50V
C515	1-128-398-11	ELECT CHIP 220uF	20% 16V	C596	1-164-854-11	CERAMIC CHIP 15PF	5% 50V
C516	1-164-156-11	CERAMIC CHIP 0.1uF	25V	C597	1-164-870-11	CERAMIC CHIP 68PF	5% 50V
C517	1-128-394-11	ELECT CHIP 220uF	20% 10V	C598	1-164-854-11	CERAMIC CHIP 15PF	5% 50V
C518	1-112-717-91	CERAMIC CHIP 1uF	10% 6.3V	C599	1-164-870-11	CERAMIC CHIP 68PF	5% 50V
C519	1-165-908-11	CERAMIC CHIP 1uF	10% 10V	C701	1-126-193-11	ELECT CHIP 1uF	20% 50V
C520	1-165-908-11	CERAMIC CHIP 1uF	10% 10V	C703	1-162-970-11	CERAMIC CHIP 0.01uF	10% 25V
C521	1-165-908-11	CERAMIC CHIP 1uF	10% 10V (EXCEPT CND)	C704	1-162-964-11	CERAMIC CHIP 0.001uF	10% 50V
C522	1-165-908-11	CERAMIC CHIP 1uF	10% 10V	C706	1-107-826-11	CERAMIC CHIP 0.1uF	10% 16V
C523	1-165-908-11	CERAMIC CHIP 1uF	10% 10V	C707	1-137-807-31	ELECT 100uF	20% 50V
C524	1-165-908-11	CERAMIC CHIP 1uF	10% 10V (EXCEPT CND)	C708	1-137-807-31	ELECT 100uF	20% 50V
C525	1-216-864-11	SHORT CHIP 0		C709	1-137-807-31	ELECT 100uF	20% 50V
C526	1-107-826-11	CERAMIC CHIP 0.1uF	10% 16V	C710	1-137-807-31	ELECT 100uF	20% 50V
C527	1-126-925-91	ELECT 470uF	20% 10V	C712	1-107-826-11	CERAMIC CHIP 0.1uF	10% 16V
C528	1-107-826-11	CERAMIC CHIP 0.1uF	10% 16V	C713	1-115-185-11	CERAMIC CHIP 0.033uF	10% 50V
C529	1-107-826-11	CERAMIC CHIP 0.1uF	10% 16V	C718	1-115-185-11	CERAMIC CHIP 0.033uF	10% 50V
C530	1-107-826-11	CERAMIC CHIP 0.1uF	10% 16V				
C532	1-164-360-11	CERAMIC CHIP 0.1uF	16V				
C533	1-107-826-11	CERAMIC CHIP 0.1uF	10% 16V				
C534	1-126-933-11	ELECT 100uF	20% 16V				
C535	1-107-826-11	CERAMIC CHIP 0.1uF	10% 16V				

HCD-MX500i/MX550i

MAIN

Ref. No.	Part No.	Description	Remark	Ref. No.	Part No.	Description	Remark
C719	1-114-994-11	ELECT	2200uF 20% 35V	C792	1-107-826-11	CERAMIC CHIP 0.1uF 10% 16V	
C720	1-131-704-11	FILM	1uF 5% 50V	C793	1-165-908-11	CERAMIC CHIP 1uF 10% 10V	
C721	1-165-908-11	CERAMIC CHIP	1uF 10% 10V	C794	1-125-837-11	CERAMIC CHIP 1uF 10% 6.3V	
C722	1-162-966-11	CERAMIC CHIP	0.0022uF 10% 50V	C795	1-165-908-11	CERAMIC CHIP 1uF 10% 10V	
C723	1-162-966-11	CERAMIC CHIP	0.0022uF 10% 50V	C796	1-107-826-11	CERAMIC CHIP 0.1uF 10% 16V	
C724	1-162-966-11	CERAMIC CHIP	0.0022uF 10% 50V	C797	1-107-826-11	CERAMIC CHIP 0.1uF 10% 16V	
C725	1-162-966-11	CERAMIC CHIP	0.0022uF 10% 50V	C798	1-165-722-11	ELECT 100uF 20% 10V	
C726	1-125-838-11	CERAMIC CHIP	2.2uF 10% 6.3V	C799	1-165-908-11	CERAMIC CHIP 1uF 10% 10V	
C727	1-165-908-11	CERAMIC CHIP	1uF 10% 10V	C801	1-162-970-11	CERAMIC CHIP 0.01uF 10% 25V	
C728	1-131-704-11	FILM	1uF 5% 50V	C804	1-162-964-11	CERAMIC CHIP 0.001uF 10% 50V	
C729	1-126-949-11	ELECT	220uF 20% 35V	C806	1-107-826-11	CERAMIC CHIP 0.1uF 10% 16V	
C731	1-165-492-21	ELECT CHIP	100uF 20% 10V	C807	1-162-927-11	CERAMIC CHIP 100PF 5% 50V	
C733	1-107-826-11	CERAMIC CHIP	0.1uF 10% 16V	C808	1-162-927-11	CERAMIC CHIP 100PF 5% 50V	
C734	1-107-826-11	CERAMIC CHIP	0.1uF 10% 16V	C809	1-162-927-11	CERAMIC CHIP 100PF 5% 50V	
C735	1-126-964-11	ELECT	10uF 20% 50V	C820	1-126-964-11	ELECT 10uF 20% 50V	
C736	1-126-601-11	ELECT CHIP	2.2uF 20% 50V	C821	1-115-339-11	CERAMIC CHIP 0.1uF 10% 50V	
C737	1-162-968-11	CERAMIC CHIP	0.0047uF 10% 50V	C822	1-162-966-11	CERAMIC CHIP 0.0022uF 10% 50V	
C738	1-124-779-00	ELECT CHIP	10uF 20% 16V	C823	1-162-966-11	CERAMIC CHIP 0.0022uF 10% 50V	
C739	1-165-908-11	CERAMIC CHIP	1uF 10% 10V	C824	1-162-966-11	CERAMIC CHIP 0.0022uF 10% 50V	
C740	1-137-649-31	ELECT	220uF 20% 10V	C825	1-162-966-11	CERAMIC CHIP 0.0022uF 10% 50V	
C741	1-107-826-11	CERAMIC CHIP	0.1uF 10% 16V	C826	1-162-966-11	CERAMIC CHIP 0.0022uF 10% 50V	
C744	1-125-891-11	CERAMIC CHIP	0.47uF 10% 10V	C827	1-162-966-11	CERAMIC CHIP 0.0022uF 10% 50V	
C745	1-107-826-11	CERAMIC CHIP	0.1uF 10% 16V	C828	1-162-966-11	CERAMIC CHIP 0.0022uF 10% 50V	
C746	1-107-826-11	CERAMIC CHIP	0.1uF 10% 16V	C829	1-162-966-11	CERAMIC CHIP 0.0022uF 10% 50V	
C747	1-104-658-91	ELECT	100uF 20% 10V	C844	1-162-964-11	CERAMIC CHIP 0.001uF 10% 50V	
C751	1-126-193-11	ELECT CHIP	1uF 20% 50V	C845	1-162-964-11	CERAMIC CHIP 0.001uF 10% 50V	
C752	1-107-826-11	CERAMIC CHIP	0.1uF 10% 16V	C846	1-162-964-11	CERAMIC CHIP 0.001uF 10% 50V	
C753	1-165-722-11	ELECT	100uF 20% 10V	C847	1-162-964-11	CERAMIC CHIP 0.001uF 10% 50V	
C754	1-162-964-11	CERAMIC CHIP	0.001uF 10% 50V	C856	1-107-826-11	CERAMIC CHIP 0.1uF 10% 16V	
C756	1-107-826-11	CERAMIC CHIP	0.1uF 10% 16V	C857	1-165-908-11	CERAMIC CHIP 1uF 10% 10V	
C757	1-126-923-91	ELECT	220uF 20% 10V	C863	1-107-826-11	CERAMIC CHIP 0.1uF 10% 16V	
C758	1-107-826-11	CERAMIC CHIP	0.1uF 10% 16V			< CONNECTOR >	
C759	1-165-908-11	CERAMIC CHIP	1uF 10% 10V	CN401	1-779-277-11	CONNECTOR, FFC (LIF (NON-ZIF)) 9P	
C761	1-165-908-11	CERAMIC CHIP	1uF 10% 10V	CN402	1-564-706-11	PIN, CONNECTOR (SMALL TYPE) 4P	
C762	1-107-826-11	CERAMIC CHIP	0.1uF 10% 16V	CN403	1-779-281-11	CONNECTOR, FFC (LIF (NON-ZIF)) 13P	
C763	1-115-185-11	CERAMIC CHIP	0.033uF 10% 50V	CN405	1-784-770-11	CONNECTOR, FFC 9P (CND, CH, SP)	
C764	1-115-339-11	CERAMIC CHIP	0.1uF 10% 50V	CN406	1-568-830-11	CONNECTOR, FFC 11P (MX500i: AEP/MX550i)	
C765	1-115-339-11	CERAMIC CHIP	0.1uF 10% 50V	CN407	1-779-277-11	CONNECTOR, FFC (LIF (NON-ZIF)) 9P (MX550i)	
C766	1-115-339-11	CERAMIC CHIP	0.1uF 10% 50V	CN408	1-779-295-11	CONNECTOR, FFC (LIF (NON-ZIF)) 27P (EXCEPT CND)	
C767	1-115-339-11	CERAMIC CHIP	0.1uF 10% 50V	CN409	1-779-281-11	CONNECTOR, FFC (LIF (NON-ZIF)) 13P	
C768	1-115-185-11	CERAMIC CHIP	0.033uF 10% 50V	CN410	1-779-273-11	CONNECTOR, FFC (LIF (NON-ZIF)) 5P	
C769	1-114-994-11	ELECT	2200uF 20% 35V	* CN412	1-564-711-11	PIN, CONNECTOR (SMALL TYPE) 9P	
C770	1-131-704-11	FILM	1uF 5% 50V	CN415	1-779-287-11	CONNECTOR, FFC (LIF (NON-ZIF)) 19P (CND)	
C771	1-162-970-11	CERAMIC CHIP	0.01uF 10% 25V	CN417	1-564-705-11	PIN, CONNECTOR (SMALL TYPE) 3P	
C772	1-162-966-11	CERAMIC CHIP	0.0022uF 10% 50V	CN702	1-819-131-11	PIN, CONNECTOR 3P	
C773	1-162-966-11	CERAMIC CHIP	0.0022uF 10% 50V	CN703	1-819-130-11	PIN, CONNECTOR 2P	
C774	1-162-966-11	CERAMIC CHIP	0.0022uF 10% 50V	CN704	1-819-132-11	PIN, CONNECTOR 4P	
C775	1-162-966-11	CERAMIC CHIP	0.0022uF 10% 50V			< DIODE >	
C776	1-165-908-11	CERAMIC CHIP	1uF 10% 10V	D501	6-502-961-01	DIODE DA2J10100L	
C777	1-131-704-11	FILM	1uF 5% 50V	D502	6-502-961-01	DIODE DA2J10100L	
C778	1-125-838-11	CERAMIC CHIP	2.2uF 10% 6.3V	D503	6-502-961-01	DIODE DA2J10100L	
C779	1-165-908-11	CERAMIC CHIP	1uF 10% 10V	D705	6-501-696-01	DIODE RSA39LTE25	
C780	1-165-908-11	CERAMIC CHIP	1uF 10% 10V	D706	6-501-696-01	DIODE RSA39LTE25	
C781	1-137-649-31	ELECT	220uF 20% 10V	D755	6-501-696-01	DIODE RSA39LTE25	
C784	1-162-911-11	CERAMIC CHIP	6PF 0.5PF 50V	D765	6-501-696-01	DIODE RSA39LTE25	
C785	1-162-910-11	CERAMIC CHIP	5PF 0.25PF 50V				
C786	1-165-908-11	CERAMIC CHIP	1uF 10% 10V				
C787	1-107-826-11	CERAMIC CHIP	0.1uF 10% 16V				
C788	1-107-826-11	CERAMIC CHIP	0.1uF 10% 16V				
C789	1-165-908-11	CERAMIC CHIP	1uF 10% 10V				

Ref. No.	Part No.	Description	Remark	Ref. No.	Part No.	Description	Remark
		< EARTH TERMINAL >		IC703	6-701-261-01	IC MC74VHC74DTR2	
* EP501	1-537-738-21	TERMINAL, EARTH		IC704	6-702-302-01	IC TK11133CSCL-G	
* EP701	1-537-738-21	TERMINAL, EARTH		IC705	6-705-979-01	IC CXD9788AR	
* EP702	1-537-738-21	TERMINAL, EARTH		IC707	6-713-634-01	IC CXD9965TN	
ET701	1-780-482-11	EARTH TERMINAL		IC709	6-701-189-01	IC MC74VHC1GU04DFT1	
ET702	1-780-482-11	EARTH TERMINAL		IC710	6-713-034-01	IC KIA7812API-U/PF	
		< JUMPER RESISTER >		IC711	6-715-392-01	IC AK5358BET-E2	
				IC712	6-714-743-01	IC MM3404A18URE	
						< COIL >	
FB101	1-216-864-11	SHORT CHIP	0	L701	1-469-967-21	INDUCTOR	10uH
FB201	1-216-864-11	SHORT CHIP	0	L702	1-469-967-21	INDUCTOR	10uH
FB502	1-216-864-11	SHORT CHIP	0	L703	1-469-967-21	INDUCTOR	10uH
FB504	1-216-864-11	SHORT CHIP	0 (MX550i)	L704	1-469-967-21	INDUCTOR	10uH
FB505	1-216-864-11	SHORT CHIP	0	L712	1-457-579-11	INDUCTOR	10uH
FB506	1-216-864-11	SHORT CHIP	0				
FB507	1-216-864-11	SHORT CHIP	0				
FB508	1-216-296-11	SHORT CHIP	0	L721	1-469-967-21	INDUCTOR	10uH
FB509	1-216-296-11	SHORT CHIP	0	L762	1-457-579-11	INDUCTOR	10uH
FB510	1-216-864-11	SHORT CHIP	0				
						< TRANSISTOR >	
FB511	1-216-864-11	SHORT CHIP	0	Q106	8-729-043-90	TRANSISTOR	IMX9T110
FB512	1-216-295-00	SHORT CHIP	0	Q504	8-729-027-26	TRANSISTOR	DTA114YKA-T146
FB513	1-216-864-11	SHORT CHIP	0	Q505	8-729-027-43	TRANSISTOR	DTC114EKA-T146
FB514	1-216-864-11	SHORT CHIP	0 (EXCEPT CND)	Q506	8-729-027-43	TRANSISTOR	DTC114EKA-T146
FB515	1-216-864-11	SHORT CHIP	0	Q507	8-729-027-23	TRANSISTOR	DTA114EKA-T146
FB516	1-216-864-11	SHORT CHIP	0 (MX550i)				
FB517	1-216-864-11	SHORT CHIP	0	Q508	8-729-027-43	TRANSISTOR	DTC114EKA-T146
FB518	1-216-864-11	SHORT CHIP	0	Q509	6-551-696-01	TRANSISTOR	ISA1235AC1TP-1EF
FB519	1-216-296-11	SHORT CHIP	0 (EXCEPT CND)	Q512	8-729-027-43	TRANSISTOR	DTC114EKA-T146
FB520	1-216-296-11	SHORT CHIP	0 (EXCEPT CND)	Q516	8-729-620-07	TRANSISTOR	2SC3052EF-T1-LEF
				Q517	8-729-027-50	TRANSISTOR	DTC123JKA-T146
FB521	1-216-296-11	SHORT CHIP	0				
FB522	1-216-296-11	SHORT CHIP	0	Q701	8-729-620-07	TRANSISTOR	2SC3052EF-T1-LEF
FB523	1-216-864-11	SHORT CHIP	0 (MX550i)	Q702	6-551-696-01	TRANSISTOR	ISA1235AC1TP-1EF
FB524	1-216-864-11	SHORT CHIP	0 (MX550i)	Q703	6-551-696-01	TRANSISTOR	ISA1235AC1TP-1EF
FB534	1-216-864-11	SHORT CHIP	0	Q752	6-551-696-01	TRANSISTOR	ISA1235AC1TP-1EF
				Q753	6-551-696-01	TRANSISTOR	ISA1235AC1TP-1EF
FB535	1-216-296-11	SHORT CHIP	0				
FB701	1-216-864-11	SHORT CHIP	0			< RESISTOR/CAPACITOR >	
FB702	1-216-864-11	SHORT CHIP	0	R101	1-216-849-11	METAL CHIP	220K 5% 1/10W
FB703	1-216-864-11	SHORT CHIP	0	R102	1-216-851-11	METAL CHIP	330K 5% 1/10W
FB704	1-216-864-11	SHORT CHIP	0	R103	1-216-845-11	METAL CHIP	100K 5% 1/10W
				R104	1-216-845-11	METAL CHIP	100K 5% 1/10W
FB705	1-216-864-11	SHORT CHIP	0	R108	1-216-829-11	METAL CHIP	4.7K 5% 1/10W
FB706	1-216-864-11	SHORT CHIP	0				
		< IC >		R111	1-216-821-11	METAL CHIP	1K 5% 1/10W
IC401	A-1784-237-A	IC R5F364AEDFA (for SERVICE)		R112	1-216-833-11	METAL CHIP	10K 5% 1/10W
		(MX500i: AEP, CH, SP)		R113	1-216-833-11	METAL CHIP	10K 5% 1/10W
IC401	A-1784-238-A	IC R5F364AEDFA (for SERVICE) (MX550i)		R114	1-216-829-11	METAL CHIP	4.7K 5% 1/10W
IC401	A-1784-347-A	IC R5F364AEDFA (for SERVICE) (CND)		R115	1-216-821-11	METAL CHIP	1K 5% 1/10W
IC402	6-713-362-01	IC MFI341S2164					(MX550i)
IC405	6-702-302-01	IC TK11133CSCL-G		R120	1-218-879-11	METAL CHIP	22K 0.5% 1/10W
				R121	1-218-879-11	METAL CHIP	22K 0.5% 1/10W
IC502	6-713-384-01	IC BD3491FS-SE2		R125	1-216-809-11	METAL CHIP	100 5% 1/10W
IC503	8-759-278-58	IC NJM4558V-TE2		R127	1-216-809-11	METAL CHIP	100 5% 1/10W
IC504	6-705-337-01	IC TK11150CSCL-G		R134	1-216-809-11	METAL CHIP	100 5% 1/10W
IC505	6-712-613-01	IC SI-3010KM-TLS					
IC506	6-715-266-01	IC BD8410FPS-E2 (EXCEPT CND)		R137	1-216-809-11	METAL CHIP	100 5% 1/10W
				R142	1-218-879-11	METAL CHIP	22K 0.5% 1/10W
IC507	8-759-598-69	IC BA6956AN					(MX550i)
IC508	6-702-302-01	IC TK11133CSCL-G		R143	1-218-879-11	METAL CHIP	22K 0.5% 1/10W
IC509	6-702-302-01	IC TK11133CSCL-G (EXCEPT CND)					(MX550i)
IC510	6-715-266-01	IC BD8410FPS-E2		R144	1-216-809-11	METAL CHIP	100 5% 1/10W
IC511	8-759-278-58	IC NJM4558V-TE2 (MX550i)					(MX550i)
				R145	1-218-879-11	METAL CHIP	22K 0.5% 1/10W
IC515	8-759-278-58	IC NJM4558V-TE2					(MX550i)
IC702	6-715-134-01	IC MM3404A33URE					

HCD-MX500i/MX550i

MAIN

Ref. No.	Part No.	Description	Remark			Ref. No.	Part No.	Description	Remark		
R147	1-218-879-11	METAL CHIP	22K	0.5%	1/10W (MX550i)	R367	1-216-864-11	SHORT CHIP	0		
R157	1-216-849-11	METAL CHIP	220K	5%	1/10W	R371	1-216-864-11	SHORT CHIP	0		
R161	1-216-296-11	SHORT CHIP	0			R372	1-216-833-11	METAL CHIP	10K	5%	1/10W
R162	1-216-296-11	SHORT CHIP	0			R373	1-216-833-11	METAL CHIP	10K	5%	1/10W
R163	1-216-813-11	METAL CHIP	220	5%	1/10W	R374	1-216-833-11	METAL CHIP	10K	5%	1/10W
R201	1-216-849-11	METAL CHIP	220K	5%	1/10W	R388	1-216-829-11	METAL CHIP	4.7K	5%	1/10W
R202	1-216-851-11	METAL CHIP	330K	5%	1/10W	R389	1-216-833-11	METAL CHIP	10K	5%	1/10W
R203	1-216-845-11	METAL CHIP	100K	5%	1/10W	R391	1-216-821-11	METAL CHIP	1K	5%	1/10W
R204	1-216-845-11	METAL CHIP	100K	5%	1/10W	R398	1-216-864-11	SHORT CHIP	0		
R209	1-216-829-11	METAL CHIP	4.7K	5%	1/10W	R399	1-216-864-11	SHORT CHIP	0		
R211	1-216-821-11	METAL CHIP	1K	5%	1/10W	R400	1-216-833-11	METAL CHIP	10K	5%	1/10W
R212	1-216-833-11	METAL CHIP	10K	5%	1/10W	R401	1-216-809-11	METAL CHIP	100	5%	1/10W
R213	1-216-833-11	METAL CHIP	10K	5%	1/10W	R402	1-216-809-11	METAL CHIP	100	5%	1/10W
R214	1-216-829-11	METAL CHIP	4.7K	5%	1/10W	R403	1-216-809-11	METAL CHIP	100	5%	1/10W
R215	1-216-821-11	METAL CHIP	1K	5%	1/10W (MX550i)	R404	1-216-809-11	METAL CHIP	100	5%	1/10W
R221	1-218-879-11	METAL CHIP	22K	0.5%	1/10W	R408	1-216-809-11	METAL CHIP	100	5%	1/10W
R232	1-216-809-11	METAL CHIP	100	5%	1/10W	R409	1-216-833-11	METAL CHIP	10K	5%	1/10W
R233	1-216-809-11	METAL CHIP	100	5%	1/10W	R410	1-219-570-11	METAL CHIP	10M	5%	1/10W
R234	1-216-809-11	METAL CHIP	100	5%	1/10W	R411	1-216-849-11	METAL CHIP	220K	5%	1/10W
R237	1-216-809-11	METAL CHIP	100	5%	1/10W	R412	1-216-833-11	METAL CHIP	10K	5%	1/10W
R241	1-218-879-11	METAL CHIP	22K	0.5%	1/10W (MX550i)	R413	1-216-864-11	SHORT CHIP	0		
R242	1-218-879-11	METAL CHIP	22K	0.5%	1/10W (MX550i)	R414	1-216-809-11	METAL CHIP	100	5%	1/10W
R243	1-216-809-11	METAL CHIP	100	5%	1/10W (MX550i)	R416	1-216-864-11	SHORT CHIP	0 (EXCEPT CND)		
R245	1-216-864-11	SHORT CHIP	0			R417	1-216-833-11	METAL CHIP	10K	5%	1/10W
R246	1-216-864-11	SHORT CHIP	0			R418	1-216-809-11	METAL CHIP	100	5%	1/10W (MX500i: AEP/MX550i)
R247	1-216-809-11	METAL CHIP	100	5%	1/10W	R419	1-216-809-11	METAL CHIP	100	5%	1/10W
R248	1-218-879-11	METAL CHIP	22K	0.5%	1/10W (MX550i)	R420	1-216-841-11	METAL CHIP	47K	5%	1/10W
R249	1-218-879-11	METAL CHIP	22K	0.5%	1/10W (MX550i)	R422	1-216-809-11	METAL CHIP	100	5%	1/10W
R250	1-216-295-00	SHORT CHIP	0			R424	1-216-809-11	METAL CHIP	100	5%	1/10W
R251	1-216-295-00	SHORT CHIP	0			R426	1-216-809-11	METAL CHIP	100	5%	1/10W
R252	1-216-809-11	METAL CHIP	100	5%	1/10W	R427	1-216-809-11	METAL CHIP	100	5%	1/10W (EXCEPT CND)
R253	1-216-809-11	METAL CHIP	100	5%	1/10W	R428	1-216-809-11	METAL CHIP	100	5%	1/10W
R254	1-216-809-11	METAL CHIP	100	5%	1/10W	R429	1-216-829-11	METAL CHIP	4.7K	5%	1/10W
R255	1-216-809-11	METAL CHIP	100	5%	1/10W	R430	1-216-829-11	METAL CHIP	4.7K	5%	1/10W
R257	1-216-849-11	METAL CHIP	220K	5%	1/10W	R431	1-216-809-11	METAL CHIP	100	5%	1/10W
R258	1-216-845-11	METAL CHIP	100K	5%	1/10W	R432	1-216-809-11	METAL CHIP	100	5%	1/10W
R259	1-216-845-11	METAL CHIP	100K	5%	1/10W	R433	1-216-809-11	METAL CHIP	100	5%	1/10W
R262	1-216-813-11	METAL CHIP	220	5%	1/10W	R434	1-216-809-11	METAL CHIP	100	5%	1/10W
R349	1-216-864-11	SHORT CHIP	0			R435	1-216-809-11	METAL CHIP	100	5%	1/10W
R350	1-216-864-11	SHORT CHIP	0			R436	1-216-809-11	METAL CHIP	100	5%	1/10W
R351	1-216-864-11	SHORT CHIP	0			R437	1-216-809-11	METAL CHIP	100	5%	1/10W
R352	1-216-864-11	SHORT CHIP	0			R438	1-216-809-11	METAL CHIP	100	5%	1/10W
R353	1-216-864-11	SHORT CHIP	0			R439	1-216-809-11	METAL CHIP	100	5%	1/10W
R354	1-216-864-11	SHORT CHIP	0			R440	1-216-809-11	METAL CHIP	100	5%	1/10W
R355	1-216-864-11	SHORT CHIP	0			R441	1-216-809-11	METAL CHIP	100	5%	1/10W
R356	1-216-864-11	SHORT CHIP	0			R442	1-216-809-11	METAL CHIP	100	5%	1/10W
R357	1-216-864-11	SHORT CHIP	0 (MX500i: AEP/MX550i)			R443	1-216-809-11	METAL CHIP	100	5%	1/10W
R358	1-216-864-11	SHORT CHIP	0 (MX500i: AEP/MX550i)			R444	1-216-809-11	METAL CHIP	100	5%	1/10W
R359	1-216-864-11	SHORT CHIP	0			R445	1-216-809-11	METAL CHIP	100	5%	1/10W
R360	1-107-826-11	CERAMIC CHIP	0.1uF	10%	16V	R446	1-216-809-11	METAL CHIP	100	5%	1/10W
R362	1-216-864-11	SHORT CHIP	0 (MX550i)			R447	1-216-809-11	METAL CHIP	100	5%	1/10W
R363	1-216-864-11	SHORT CHIP	0 (MX550i)			R448	1-216-809-11	METAL CHIP	100	5%	1/10W
R364	1-216-864-11	SHORT CHIP	0			R449	1-216-809-11	METAL CHIP	100	5%	1/10W (MX550i)
R365	1-216-864-11	SHORT CHIP	0			R450	1-216-809-11	METAL CHIP	100	5%	1/10W (MX550i)
R366	1-216-864-11	SHORT CHIP	0			R451	1-216-809-11	METAL CHIP	100	5%	1/10W
						R452	1-216-809-11	METAL CHIP	100	5%	1/10W

Ref. No.	Part No.	Description	Quantity	Yield	Remark	Ref. No.	Part No.	Description	Quantity	Yield	Remark
R453	1-216-809-11	METAL CHIP	100	5%	1/10W	R519	1-216-833-11	METAL CHIP	10K	5%	1/10W
R454	1-216-809-11	METAL CHIP	100	5%	1/10W	R520	1-216-821-11	METAL CHIP	1K	5%	1/10W
R455	1-216-809-11	METAL CHIP	100	5%	1/10W	R521	1-216-825-11	METAL CHIP	2.2K	5%	1/10W
R456	1-216-809-11	METAL CHIP	100	5%	1/10W	R522	1-216-829-11	METAL CHIP	4.7K	5%	1/10W
(MX500i: AEP/MX550i)						R523	1-216-825-11	METAL CHIP	2.2K	5%	1/10W
R457	1-216-821-11	METAL CHIP	1K	5%	1/10W	R524	1-216-829-11	METAL CHIP	4.7K	5%	1/10W
R458	1-216-821-11	METAL CHIP	1K	5%	1/10W	R529	1-216-833-11	METAL CHIP	10K	5%	1/10W
R459	1-216-809-11	METAL CHIP	100	5%	1/10W	R530	1-216-841-11	METAL CHIP	47K	5%	1/10W
R460	1-216-809-11	METAL CHIP	100	5%	1/10W	R531	1-216-841-11	METAL CHIP	47K	5%	1/10W
R461	1-216-809-11	METAL CHIP	100	5%	1/10W	R532	1-216-821-11	METAL CHIP	1K	5%	1/10W
R462	1-216-809-11	METAL CHIP	100	5%	1/10W	R533	1-216-822-11	METAL CHIP	1.2K	5%	1/10W
R463	1-216-821-11	METAL CHIP	1K	5%	1/10W	R534	1-216-833-11	METAL CHIP	10K	5%	1/10W
R464	1-216-809-11	METAL CHIP	100	5%	1/10W	R535	1-216-829-11	METAL CHIP	4.7K	5%	1/10W
R465	1-216-821-11	METAL CHIP	1K	5%	1/10W	R536	1-216-841-11	METAL CHIP	47K	5%	1/10W
(MX500i: CND)						R537	1-218-871-11	METAL CHIP	10K	0.5%	1/10W
R465	1-216-829-11	METAL CHIP	4.7K	5%	1/10W	R538	1-218-847-11	METAL CHIP	1K	0.5%	1/10W
(MX500i: AEP/MX550i)						R539	1-218-879-11	METAL CHIP	22K	0.5%	1/10W
R466	1-216-809-11	METAL CHIP	100	5%	1/10W	R541	1-216-833-11	METAL CHIP	10K	5%	1/10W
R469	1-216-809-11	METAL CHIP	100	5%	1/10W	R542	1-218-879-11	METAL CHIP	22K	0.5%	1/10W
R470	1-216-809-11	METAL CHIP	100	5%	1/10W	R546	1-216-833-11	METAL CHIP	10K	5%	1/10W
R471	1-216-809-11	METAL CHIP	100	5%	1/10W	R547	1-216-829-11	METAL CHIP	4.7K	5%	1/10W
R472	1-216-821-11	METAL CHIP	1K	5%	1/10W	R548	1-216-829-11	METAL CHIP	4.7K	5%	1/10W
R473	1-216-833-11	METAL CHIP	10K	5%	1/10W	R553	1-218-879-11	METAL CHIP	22K	0.5%	1/10W
R474	1-216-857-11	METAL CHIP	1M	5%	1/10W	R555	1-216-864-11	SHORT CHIP	0		
R475	1-216-833-11	METAL CHIP	10K	5%	1/10W	R556	1-216-841-11	METAL CHIP	47K	5%	1/10W
R476	1-216-809-11	METAL CHIP	100	5%	1/10W	(CND, CH, SP)					
R477	1-216-809-11	METAL CHIP	100	5%	1/10W	R557	1-216-833-11	METAL CHIP	10K	5%	1/10W
R478	1-216-809-11	METAL CHIP	100	5%	1/10W	R558	1-216-833-11	METAL CHIP	10K	5%	1/10W
R480	1-216-821-11	METAL CHIP	1K	5%	1/10W	R559	1-216-864-11	SHORT CHIP	0 (EXCEPT CND)		
R482	1-216-809-11	METAL CHIP	100	5%	1/10W	R560	1-216-845-11	METAL CHIP	100K	5%	1/10W
R483	1-216-821-11	METAL CHIP	1K	5%	1/10W	(EXCEPT CND)					
R484	1-216-809-11	METAL CHIP	100	5%	1/10W	R561	1-218-863-11	METAL CHIP	4.7K	0.5%	1/10W
R485	1-216-809-11	METAL CHIP	100	5%	1/10W	R562	1-216-845-11	METAL CHIP	100K	5%	1/10W
R486	1-216-809-11	METAL CHIP	100	5%	1/10W	R565	1-216-829-11	METAL CHIP	4.7K	5%	1/10W
R487	1-216-809-11	METAL CHIP	100	5%	1/10W	(CND)					
R488	1-216-809-11	METAL CHIP	100	5%	1/10W	R565	1-216-864-11	SHORT CHIP	0 (CH, SP)		
R489	1-216-809-11	METAL CHIP	100	5%	1/10W	R570	1-216-833-11	METAL CHIP	10K	5%	1/10W
R490	1-216-809-11	METAL CHIP	100	5%	1/10W	R571	1-216-833-11	METAL CHIP	10K	5%	1/10W
R491	1-216-809-11	METAL CHIP	100	5%	1/10W	R572	1-216-864-11	SHORT CHIP	0		
R492	1-216-809-11	METAL CHIP	100	5%	1/10W	R574	1-216-821-11	METAL CHIP	1K	5%	1/10W
(EXCEPT CND)						R576	1-216-833-11	METAL CHIP	10K	5%	1/10W
R493	1-216-809-11	METAL CHIP	100	5%	1/10W	R577	1-216-833-11	METAL CHIP	10K	5%	1/10W
R494	1-216-809-11	METAL CHIP	100	5%	1/10W	R579	1-216-849-11	METAL CHIP	220K	5%	1/10W
R495	1-216-809-11	METAL CHIP	100	5%	1/10W	R581	1-216-809-11	METAL CHIP	100	5%	1/10W
R496	1-216-809-11	METAL CHIP	100	5%	1/10W	(EXCEPT CND)					
(EXCEPT CND)						R582	1-216-809-11	METAL CHIP	100	5%	1/10W
R497	1-216-809-11	METAL CHIP	100	5%	1/10W	(EXCEPT CND)					
R498	1-216-864-11	SHORT CHIP	0			R583	1-216-833-11	METAL CHIP	10K	5%	1/10W
R499	1-216-864-11	SHORT CHIP	0 (EXCEPT CND)			R584	1-216-833-11	METAL CHIP	10K	5%	1/10W
R501	1-216-864-11	SHORT CHIP	0			R585	1-216-809-11	METAL CHIP	100	5%	1/10W
R502	1-216-864-11	SHORT CHIP	0			(EXCEPT CND)					
R503	1-216-797-11	METAL CHIP	10	5%	1/10W	R586	1-216-809-11	METAL CHIP	100	5%	1/10W
R505	1-218-879-11	METAL CHIP	22K	0.5%	1/10W	(EXCEPT CND)					
R506	1-216-864-11	SHORT CHIP	0			R587	1-216-809-11	METAL CHIP	100	5%	1/10W
(EXCEPT CND)						R588	1-216-809-11	METAL CHIP	100	5%	1/10W
R513	1-218-863-11	METAL CHIP	4.7K	0.5%	1/10W	R589	1-216-809-11	METAL CHIP	100	5%	1/10W
R514	1-218-863-11	METAL CHIP	4.7K	0.5%	1/10W	R590	1-216-809-11	METAL CHIP	100	5%	1/10W
R515	1-218-907-11	METAL CHIP	330K	0.5%	1/10W	R591	1-216-864-11	SHORT CHIP	0		
R516	1-218-903-11	METAL CHIP	220K	0.5%	1/10W	R592	1-216-833-11	METAL CHIP	10K	5%	1/10W
R517	1-211-977-11	METAL CHIP	22	0.5%	1/10W	R593	1-216-821-11	METAL CHIP	1K	5%	1/10W
R518	1-216-841-11	METAL CHIP	47K	5%	1/10W	R594	1-216-833-11	METAL CHIP	10K	5%	1/10W
(CND, CH, SP)											

HCD-MX500i/MX550i

MAIN **MS-203** **POWER**

Ref. No.	Part No.	Description	Remark
R595	1-216-833-11	METAL CHIP 10K	5% 1/10W
R596	1-216-833-11	METAL CHIP 10K	5% 1/10W
R597	1-216-845-11	METAL CHIP 100K	5% 1/10W
R598	1-216-853-11	METAL CHIP 470K	5% 1/10W
R599	1-216-845-11	METAL CHIP 100K	5% 1/10W
R600	1-216-837-11	METAL CHIP 22K	5% 1/10W
R601	1-216-837-11	METAL CHIP 22K	5% 1/10W
R701	1-216-864-11	SHORT CHIP 0	
R706	1-216-809-11	METAL CHIP 100	5% 1/10W
R711	1-216-809-11	METAL CHIP 100	5% 1/10W
R713	1-216-809-11	METAL CHIP 100	5% 1/10W
R714	1-216-809-11	METAL CHIP 100	5% 1/10W
R718	1-216-864-11	SHORT CHIP 0	
R724	1-216-138-00	METAL CHIP 3.3	5% 1/8W
R725	1-216-138-00	METAL CHIP 3.3	5% 1/8W
R726	1-216-845-11	METAL CHIP 100K	5% 1/10W
R727	1-216-845-11	METAL CHIP 100K	5% 1/10W
R728	1-216-845-11	METAL CHIP 100K	5% 1/10W
R731	1-216-805-11	METAL CHIP 47	5% 1/10W
R733	1-216-805-11	METAL CHIP 47	5% 1/10W
R736	1-216-809-11	METAL CHIP 100	5% 1/10W
R743	1-216-809-11	METAL CHIP 100	5% 1/10W
R745	1-216-809-11	METAL CHIP 100	5% 1/10W
R746	1-216-809-11	METAL CHIP 100	5% 1/10W
R747	1-216-817-11	METAL CHIP 470	5% 1/10W
R751	1-216-864-11	SHORT CHIP 0	
R752	1-216-809-11	METAL CHIP 100	5% 1/10W
R753	1-216-295-00	SHORT CHIP 0	
R754	1-216-809-11	METAL CHIP 100	5% 1/10W
R756	1-216-809-11	METAL CHIP 100	5% 1/10W
R758	1-216-837-11	METAL CHIP 22K	5% 1/10W
R765	1-216-864-11	SHORT CHIP 0	
R766	1-216-158-00	METAL CHIP 22	5% 1/8W
R767	1-216-158-00	METAL CHIP 22	5% 1/8W
R768	1-216-158-00	METAL CHIP 22	5% 1/8W
R769	1-216-158-00	METAL CHIP 22	5% 1/8W
R774	1-216-138-00	METAL CHIP 3.3	5% 1/8W
R775	1-216-138-00	METAL CHIP 3.3	5% 1/8W
R776	1-216-845-11	METAL CHIP 100K	5% 1/10W
R777	1-216-845-11	METAL CHIP 100K	5% 1/10W
R778	1-216-845-11	METAL CHIP 100K	5% 1/10W
R780	1-216-801-11	METAL CHIP 22	5% 1/10W
R781	1-216-817-11	METAL CHIP 470	5% 1/10W
R782	1-216-857-11	METAL CHIP 1M	5% 1/10W
R783	1-216-801-11	METAL CHIP 22	5% 1/10W
R784	1-216-809-11	METAL CHIP 100	5% 1/10W
R785	1-216-809-11	METAL CHIP 100	5% 1/10W
R786	1-216-809-11	METAL CHIP 100	5% 1/10W
R787	1-216-809-11	METAL CHIP 100	5% 1/10W
R788	1-216-809-11	METAL CHIP 100	5% 1/10W
R789	1-216-809-11	METAL CHIP 100	5% 1/10W
R792	1-216-864-11	SHORT CHIP 0	
R793	1-216-841-11	METAL CHIP 47K	5% 1/10W
< VIBRATOR >			
X401	1-814-067-11	OSCILLATOR, CRYSTAL (32.768KHz)	
X402	1-795-058-21	VIBRATOR, CERAMIC (5MHz)	
X703	1-814-266-11	VIBRATOR, CRYSTAL (49.152MHz)	

Ref. No.	Part No.	Description	Remark
MS-203 BOARD *****			
When the MS-203 board is damaged, exchange the entire CDM85 (CD) ASSY. *****			
POWER BOARD *****			
< CAPACITOR >			
△ C1	1-165-529-11	MYLAR 0.22uF	10% 250V
△ C2	1-165-529-11	MYLAR 0.22uF	10% 250V
△ C4	1-119-886-51	CERAMIC 470PF	10% 250V
△ C5	1-119-886-51	CERAMIC 470PF	10% 250V
△ C10	1-100-923-21	ELECT 100uF	20% 450V (EXCEPT CND)
△ C11	1-100-858-11	ELECT (BLOCK) 390uF	20% 250V (CND)
△ C12	1-100-858-11	ELECT (BLOCK) 390uF	20% 250V (CND)
△ C13	1-162-970-91	CERAMIC CHIP 0.01uF	10% 25V
△ C14	1-163-275-91	CERAMIC CHIP 0.001uF	5% 50V
△ C15	1-126-964-91	ELECT 10uF	20% 50V
△ C16	1-126-963-91	ELECT 4.7uF	20% 50V
△ C17	1-162-964-91	CERAMIC CHIP 0.001uF	10% 50V
△ C18	1-115-339-91	CERAMIC CHIP 0.1uF	10% 50V
△ C19	1-115-339-91	CERAMIC CHIP 0.1uF	10% 50V
△ C20	1-104-664-91	ELECT 47uF	20% 25V
△ C21	1-115-340-91	CERAMIC CHIP 0.22uF	10% 25V
△ C22	1-107-824-81	CERAMIC 220PF	5% 1KV
△ C23	1-107-824-81	CERAMIC 220PF	5% 1KV
△ C24	1-165-610-11	FILM 0.033uF	3% 800V
△ C25	1-126-950-91	ELECT 330uF	20% 35V
△ C602	1-115-339-91	CERAMIC CHIP 0.1uF	10% 50V
△ C603	1-162-966-91	CERAMIC CHIP 0.0022uF	10% 50V
△ C604	1-126-960-91	ELECT 1uF	20% 50V
C606	1-162-970-11	CERAMIC CHIP 0.01uF	10% 25V
C902	1-137-649-31	ELECT 220uF	20% 10V
C904	1-100-597-91	CERAMIC CHIP 0.1uF	10% 25V
C905	1-126-916-11	ELECT 1000uF	20% 6.3V
C906	1-112-231-11	ELECT 2200uF	20% 16V
C907	1-114-994-11	ELECT 2200uF	20% 35V
C908	1-216-864-11	SHORT CHIP 0	
C909	1-216-864-11	SHORT CHIP 0	
C910	1-107-726-91	CERAMIC CHIP 0.01uF	10% 16V
C913	1-126-964-11	ELECT 10uF	20% 50V
C914	1-127-715-11	CERAMIC CHIP 0.22uF	10% 16V
C915	1-127-715-11	CERAMIC CHIP 0.22uF	10% 16V
C916	1-125-898-11	CERAMIC CHIP 0.22uF	10% 50V
C917	1-100-597-91	CERAMIC CHIP 0.1uF	10% 25V
C918	1-216-864-11	SHORT CHIP 0	
C919	1-216-864-11	SHORT CHIP 0	
C920	1-112-254-11	ELECT 1000uF	20% 35V
C923	1-100-597-91	CERAMIC CHIP 0.1uF	10% 25V
C929	1-115-340-11	CERAMIC CHIP 0.22uF	10% 25V
C930	1-112-222-21	ELECT 2200uF	20% 10V
C944	1-115-340-11	CERAMIC CHIP 0.22uF	10% 25V
C945	1-125-898-11	CERAMIC CHIP 0.22uF	10% 50V
C950	1-127-715-11	CERAMIC CHIP 0.22uF	10% 16V
C952	1-126-935-11	ELECT 470uF	20% 16V
C954	1-127-715-11	CERAMIC CHIP 0.22uF	10% 16V
C956	1-100-597-91	CERAMIC CHIP 0.1uF	10% 25V

Ref. No.	Part No.	Description	Remark	Ref. No.	Part No.	Description	Remark
C957	1-126-964-11	ELECT 10uF 20%	50V			< COIL >	
C958	1-126-923-91	ELECT 220uF 20%	10V	L901	1-412-525-31	INDUCTOR 10uH	
C959	1-107-826-11	CERAMIC CHIP 0.1uF 10%	16V	L904	1-400-424-21	INDUCTOR 47uH	
C960	1-107-826-11	CERAMIC CHIP 0.1uF 10%	16V			< PHOTO COUPLER >	
		< CONNECTOR >					
△ CN1	1-564-321-11	PIN, CONNECTOR (3.96mm PITCH) 2P		△ PH11	6-600-276-01	PHOTO COUPLER PS2561AL1-1-V-W	
		< DIODE >		△ PH601	6-600-276-01	PHOTO COUPLER PS2561AL1-1-V-W	
				△ PH602	6-600-276-01	PHOTO COUPLER PS2561AL1-1-V-W	
						< TRANSISTOR >	
△ D1	8-719-077-77	DIODE D3SB60F3		△ Q011	6-551-319-01	FET 2SK3563 (LB2SONY)	
△ D2	8-719-081-58	DIODE S2V60-TA (CND)		△ Q012	6-551-319-01	FET 2SK3563 (LB2SONY)	
△ D3	8-719-081-58	DIODE S2V60-TA (CND)		△ Q601	8-729-620-07	TRANSISTOR 2SC3052EF-T1-LEF	
△ D11	8-719-979-64	DIODE UF4005/23		Q901	8-729-620-07	TRANSISTOR 2SC3052EF-T1-LEF	
△ D14	6-500-567-21	DIODE 10ERB20-TB5		Q902	8-729-620-07	TRANSISTOR 2SC3052EF-T1-LEF	
△ D15	6-501-178-01	DIODE UDZW-TE17-15B		Q903	6-551-696-01	TRANSISTOR ISA1235AC1TP-1EF	
△ D16	6-501-178-01	DIODE UDZW-TE17-15B		Q904	8-729-620-07	TRANSISTOR 2SC3052EF-T1-LEF	
△ D17	8-719-060-48	DIODE RB751V-40TE-17				< RESISTOR >	
△ D602	8-719-073-23	DIODE ST02D-200TA		△ R2	1-219-512-91	METAL 2.2M 5% 1/2W F	
△ D603	6-500-567-21	DIODE 10ERB20-TB5		△ R3	1-219-759-91	METAL 1M 5% 1/2W F	
D901	6-500-567-21	DIODE 10ERB20-TB5				(CND)	
D902	6-500-567-21	DIODE 10ERB20-TB5		△ R4	1-219-759-91	METAL 1M 5% 1/2W F	
D903	6-503-050-01	DIODE SBT80-06LS-S				(CND)	
D904	6-502-478-01	DIODE FMEN-210A		△ R10	1-218-881-91	METAL CHIP 27K 0.5% 1/10W	
D905	8-719-110-53	DIODE RD20ESB2		△ R11	1-216-864-91	SHORT CHIP 0	
D906	6-503-030-01	DIODE DZ2J160M0L		△ R12	1-245-502-31	METAL 4.7M 2% 1/4W F	
D907	6-502-990-01	DIODE SJPJ-L3VL		△ R13	1-245-502-31	METAL 4.7M 2% 1/4W F	
D910	6-503-013-01	DIODE DZ2J043M0L		△ R14	1-218-911-91	METAL CHIP 470K 0.5% 1/10W	
D911	6-500-334-01	DIODE MC2836-T112-1		△ R15	1-218-887-91	METAL CHIP 47K 0.5% 1/10W	
D913	6-500-334-01	DIODE MC2836-T112-1		△ R16	1-218-823-91	METAL CHIP 100 0.5% 1/10W	
D914	6-502-973-01	DIODE DZ2J091M0L		△ R17	1-211-989-91	METAL CHIP 68 0.5% 1/10W	
D922	6-502-961-01	DIODE DA2J10100L		△ R18	1-216-833-91	METAL CHIP 10K 5% 1/10W	
D923	6-503-022-01	DIODE DZ2J100M0L		△ R20	1-216-833-91	METAL CHIP 10K 5% 1/10W	
D927	6-502-968-01	DIODE DZ2J062M0L		△ R22	1-249-417-11	CARBON 1K 5% 1/4W F	
		< EARTH TERMINAL >		△ R23	1-217-568-31	METAL 0.22 5% 2W F	
* EP1	1-537-738-21	TERMINAL, EARTH		△ R24	1-216-821-91	METAL CHIP 1K 5% 1/10W	
* EP901	1-537-738-21	TERMINAL, EARTH		△ R25	1-247-694-81	CARBON 33 5% 1/4W F	
* EP902	1-537-738-21	TERMINAL, EARTH		△ R27	1-216-797-91	METAL CHIP 10 5% 1/10W	
		< FUSE >		△ R29	1-216-797-91	METAL CHIP 10 5% 1/10W	
△ F1	1-576-232-51	FUSE (H.B.C.) (T5AH/250V)		△ R603	1-216-853-91	METAL CHIP 470K 5% 1/10W	
		< FERRITE BEAD >		△ R604	1-249-401-11	CARBON 47 5% 1/4W F	
△ FB11	1-410-397-31	FERRITE 1.1uH		△ R605	1-216-835-91	METAL CHIP 15K 5% 1/10W	
		< FUSE HOLDER >		△ R606	1-249-381-61	CARBON 1 5% 1/4W F	
FH1	1-533-217-31	FUSE HOLDER		△ R608	1-216-821-91	METAL CHIP 1K 5% 1/10W	
FH2	1-533-217-31	FUSE HOLDER		△ R609	1-218-899-91	METAL CHIP 150K 0.5% 1/10W	
		< IC >		△ R610	1-218-907-91	METAL CHIP 330K 0.5% 1/10W	
△ IC11	6-707-749-01	IC CXD9841P		R901	1-216-821-11	METAL CHIP 1K 5% 1/10W	
△ IC601	6-708-726-01	IC MIP2F20MS1SO		R902	1-216-817-11	METAL CHIP 470 5% 1/10W	
IC904	6-713-826-01	IC SI-8001FFEK		R903	1-216-821-11	METAL CHIP 1K 5% 1/10W	
IC905	6-713-793-01	IC SI-3010KFEK		R904	1-216-845-11	METAL CHIP 100K 5% 1/10W	
IC908	6-713-031-01	IC KIA7805API-U/PF		R905	1-216-817-11	METAL CHIP 470 5% 1/10W	
IC909	6-711-947-01	IC MM1431CURE		R906	1-216-805-11	METAL CHIP 47 5% 1/10W	
				R907	1-218-863-11	METAL CHIP 4.7K 0.5% 1/10W	
				R908	1-218-879-11	METAL CHIP 22K 0.5% 1/10W	
				R909	1-218-887-11	METAL CHIP 47K 0.5% 1/10W	
				R910	1-216-821-11	METAL CHIP 1K 5% 1/10W	
				R911	1-216-833-11	METAL CHIP 10K 5% 1/10W	
				R912	1-216-841-11	METAL CHIP 47K 5% 1/10W	
				R913	1-216-833-11	METAL CHIP 10K 5% 1/10W	

HCD-MX500i/MX550i

POWER **SP** **USB**

Ref. No.	Part No.	Description	Remark
R914	1-216-821-11	METAL CHIP 1K 5%	1/10W
R915	1-216-833-11	METAL CHIP 10K 5%	1/10W
R916	1-216-817-11	METAL CHIP 470 5%	1/10W
R918	1-218-845-11	METAL CHIP 820 0.5%	1/10W
R920	1-218-893-11	METAL CHIP 82K 0.5%	1/10W
R921	1-218-879-11	METAL CHIP 22K 0.5%	1/10W
R922	1-218-871-11	METAL CHIP 10K 0.5%	1/10W
R924	1-218-883-11	METAL CHIP 33K 0.5%	1/10W
R925	1-218-871-11	METAL CHIP 10K 0.5%	1/10W
R926	1-218-887-11	METAL CHIP 47K 0.5%	1/10W
R927	1-216-821-11	METAL CHIP 1K 5%	1/10W
R928	1-216-829-11	METAL CHIP 4.7K 5%	1/10W
R929	1-216-829-11	METAL CHIP 4.7K 5%	1/10W
R930	1-216-821-11	METAL CHIP 1K 5%	1/10W
R931	1-216-827-11	METAL CHIP 3.3K 5%	1/10W
R932	1-216-829-11	METAL CHIP 4.7K 5%	1/10W
R933	1-216-833-11	METAL CHIP 10K 5%	1/10W
R934	1-216-821-11	METAL CHIP 1K 5%	1/10W
R948	1-216-833-11	METAL CHIP 10K 5%	1/10W
R951	1-216-833-11	METAL CHIP 10K 5%	1/10W
R952	1-216-829-11	METAL CHIP 4.7K 5%	1/10W
R953	1-216-821-11	METAL CHIP 1K 5%	1/10W
R955	1-216-821-11	METAL CHIP 1K 5%	1/10W
R960	1-216-825-11	METAL CHIP 2.2K 5%	1/10W
R961	1-216-821-11	METAL CHIP 1K 5%	1/10W
R962	1-216-821-11	METAL CHIP 1K 5%	1/10W
R963	1-216-829-11	METAL CHIP 4.7K 5%	1/10W
R964	1-216-821-11	METAL CHIP 1K 5%	1/10W
R965	1-216-821-11	METAL CHIP 1K 5%	1/10W
R966	1-216-827-11	METAL CHIP 3.3K 5%	1/10W
R968	1-216-833-11	METAL CHIP 10K 5%	1/10W
R969	1-218-867-11	METAL CHIP 6.8K 0.5%	1/10W
< TRANSFORMER/COIL >			
△ T1	1-445-048-21	TRANSFORMER, LINE FILTER (EXCEPT CND)	
△ T1	1-457-326-21	COIL, LINE FILTER (CND)	
△ T031	1-445-690-11	TRANSFORMER, DC-DC CONVERTER	
△ T603	1-443-942-11	TRANSFORMER, DC-DC CONVERTER	
< THERMISTOR >			
△ TH1	1-802-075-11	THERMISTOR, NTC (EXCEPT CND)	
△ TH1	1-805-901-11	THERMISTOR, NTC (CND)	
△ TH2	1-805-901-11	THERMISTOR, NTC (CND)	
< VARISTOR >			
△ VDR001	1-802-425-21	VARISTOR (TND14SV471K) (EXCEPT CND)	
△ VDR001	1-811-148-21	VARISTOR (TND10SV271K) (CND)	

SP BOARD *****			
< CAPACITOR >			
C321	1-163-021-11	CERAMIC CHIP 0.01uF 10%	50V
C322	1-163-021-11	CERAMIC CHIP 0.01uF 10%	50V
C323	1-163-021-11	CERAMIC CHIP 0.01uF 10%	50V
C324	1-163-021-11	CERAMIC CHIP 0.01uF 10%	50V
C325	1-162-964-11	CERAMIC CHIP 0.001uF 10%	50V
C326	1-162-964-11	CERAMIC CHIP 0.001uF 10%	50V
C327	1-162-964-11	CERAMIC CHIP 0.001uF 10%	50V

Ref. No.	Part No.	Description	Remark
C328	1-162-964-11	CERAMIC CHIP 0.001uF 10%	50V
< TERMINAL >			
TB322	1-780-639-11	TERMINAL BOARD (SPEAKER) 2P (SPEAKERS)	

USB BOARD (EXCEPT CND) *****			
< CAPACITOR >			
C315	1-165-989-11	CERAMIC CHIP 10uF 10%	6.3V
C316	1-107-826-11	CERAMIC CHIP 0.1uF 10%	16V
C317	1-107-826-11	CERAMIC CHIP 0.1uF 10%	16V
< CONNECTOR >			
CN316	1-822-423-11	CONNECTOR, USB (A) (←)	

MISCELLANEOUS *****			
7	1-457-413-11	CORE, FERRITE	
63	1-832-578-21	CABLE, FLEXIBLE FLAT (13 CORE)	
111	1-838-389-21	CABLE, FLEXIBLE FLAT (13 CORE)	
153	1-400-932-11	FILTER, CLAMP	
204	1-481-419-11	CORE, FERRITE	
△ 205	1-834-966-41	POWER-SUPPLY CORD (AEP, SP)	
△ 205	1-835-078-31	CORD, POWER (UK)	
△ 205	1-837-308-11	CORD, POWER-SUPPLY (CND)	
△ 205	1-837-822-21	CORD, POWER-SUPPLY (CH)	
208	1-400-092-11	CORE, FERRITE	
209	1-832-814-21	CABLE, FLEXIBLE FLAT (9 CORE) (CND, CH, SP)	
209	1-832-824-21	CABLE, FLEXIBLE FLAT (11 CORE) (AEP, UK)	
211	1-832-601-21	CABLE, FLEXIBLE FLAT (19 CORE) (CND)	
211	1-832-641-21	CABLE, FLEXIBLE FLAT (27 CORE)	
(EXCEPT CND)			
212	1-832-554-21	CABLE, FLEXIBLE FLAT (9 CORE) (MX550i)	
△ 251	A-1764-002-A	CDM85 (CD) ASSY (Including MS-213 board)	
253	1-832-539-21	CABLE, FLEXIBLE FLAT (5 CORE)	
254	1-830-688-51	WIRE (FLAT TYPE) (24 CORE)	
△ 255	8-820-321-05	DEVICE, OPTICAL KHM-313CAA/C2RP	
CN01	1-820-441-11	CONNECTOR, COAXIAL (F TYPE) (MX550i)	
DAB1	1-487-958-21	MODULE (DAB TUNER) (MX550i)	
TU1	1-693-780-11	TUNER (FM) (SP)	
TU1	1-693-781-11	TUNER (FM) (CND)	
TU1	1-693-787-11	TUNER (FM) (AEP, UK)	
TU1	1-693-788-11	TUNER (FM) (CH)	

MEMO

